

What's on the Menu?



***KinderCorner 2nd Edition Plus Theme Guide:
Unit 6***

© 2016 Success for All Foundation. All rights reserved.

Produced by the KinderCorner 2nd Edition Plus Team

| | | | |
|--------------------|-------------------|----------------------|-----------------|
| Cathy Pascone | Jennifer Austin | Lori Martin | Richard Gifford |
| Coleen Bennett | Joe H. Wilson | Marti Gastineau | Russell Jozwiak |
| Deb Branner | Karen Poe | Meghan Fay | Sarah Eitel |
| Devon Bouldin | Kate Conway | Michael Hummel | Sue Belt |
| Irene Baranyk | Kathy Brune | Michelle Zahler | Susan Perkins |
| Irina Mukhutdinova | Kelly Rose | Nancy Madden | Teresa Blanton |
| James Bravo | Kenly Novotny | Nick Leonhardt | Tina Widzbor |
| Jane Strausbaugh | Kimberly Sargeant | Patrice Case-McFadin | Tonia Hawkins |
| Janet Wisner | Laura Alexander | Patricia Johnson | Wanda Jackson |
| Jeffrey Goddard | Laurie Warner | Rebecca Prell | Wendy Fitchett |

We wish to acknowledge the coaches, teachers, and children who piloted the program and provided valuable feedback.

We wish to acknowledge the creative contributions of our collaborators at Sirius Thinking, Ltd.

The Success for All Foundation grants permission to reproduce the blackline masters of this KinderCorner 2nd Edition Plus theme guide on an as-needed basis for classroom use.

KinderCorner is brought to you by the Success for All Foundation in partnership with Sesame Workshop, the non-profit educational organization behind *Sesame Street*.

We wish to thank Pitney Bowes and Macy's for their generous funding in support of the development of engaging media for the Home Link shows.

pitney bowes  ★ macy's



A Nonprofit Education Reform Organization

300 E. Joppa Road, Suite 500, Baltimore, MD 21286

PHONE: (800) 548-4998; FAX: (410) 324-4444

E-MAIL: sfainfo@successforall.org

WEBSITE: www.successforall.org

Table of Contents

| | |
|--------------------------------------|-----|
| Why <i>What's on the Menu?</i> | 1 |
| Daily Focus..... | 2 |
| Vocabulary..... | 4 |
| Peek at the Week..... | 6 |
| You Will Need..... | 10 |
| Daily Lessons | |
| Day 1..... | 17 |
| Day 2..... | 49 |
| Day 3..... | 79 |
| Day 4..... | 105 |
| Day 5..... | 129 |
| Day 6..... | 149 |
| Day 7..... | 179 |
| Day 8..... | 203 |
| Day 9..... | 229 |
| Day 10..... | 253 |
| Appendix..... | 273 |

Why *What's on the Menu?*

Food plays a significant role in the lives of children. Some children are adventurous eaters; others will eat food only from a limited menu. Some children have big appetites; others need encouragement to eat “just five more peas.” Whatever their individual eating preferences, all children must eat—and they must eat food that is good for them. It is up to the adults in their lives, who know the benefits of a healthy diet, to help children learn to make the right choices in their food selections and portions.

Universally, children want to have energy and to grow strong. Using this desire and some entertaining literature, we hope to teach students how to make healthy food choices. The activities in this unit are intended to engage students in taking an interest in the advantages of eating a variety of food types. While five-year-olds aren't ready for all the details of the USDA's MyPlate food guide, use of this graphic throughout the unit shows students that there are different types of foods that are grouped together because they are alike in some way, that a variety of foods are needed for good health, and that different types of foods are needed in different amounts for them to grow healthy and strong. The key message we want to give by using the MyPlate food guide is that of variety; a healthful diet depends on a wide variety of foods.

Throughout the unit, we anticipate that students will see that everyone needs food to survive and that food is nearly infinite in its variety. Some students may have observed that there are types of foods as they notice restaurants identified by ethnicity. In this unit, students will see that people from different climates and cultures frequently eat foods that have their own special flavors and styles. They will also be exposed to the idea that many cultures eat foods that are similar, but that differ in appearance (e.g., bread). We chose the unit's activities and literature to entice students to be more adventurous and open minded when thinking about unfamiliar foods and to want to learn about different cultures and their foods.

We strongly urge you to arrange a field trip to a local supermarket during week 2 because children seem naturally drawn to opportunities to make discoveries through their senses in food markets. Through this innate interest, we hope to help students learn about the many behind-the-scenes activities in the market that help foods get from their sources to students' families. Seeing food divided into categories in the market will also help reinforce the concept of food groups presented in the unit.

Throughout the unit, students will learn about the win-win process and will practice finding win-win solutions to conflicts so the parties involved each get part of something they want. Students learn through this process that there is more than one way to solve a conflict. As with all units, this theme will facilitate students' development of a variety of skills in literacy, physical development, math, social relationships, cultural knowledge, and creativity in meaningful contexts.

Bon appétit!

What's on the Menu?

daily focus

- Our bodies need healthy food for energy, to make us grow, and to keep us well.
- Grains are needed for nutrition.
- Fruits and vegetables are needed for nutrition.
- Dairy foods and protein are needed for nutrition.
- Eating too many fats, sweets, and oils is unhealthy.
- Food is sold at markets.
- Foods are sorted into categories at the market.
- Markets are in every country in the world.
- There are many jobs to do in a market.
- There are many types of markets.

Creative Domain

Students will:

- pretend with objects.
- experiment with a variety of art materials.
- participate in singing and chanting activities.
- take on dramatic roles.
- respond to music with increasingly complex movements.

Cognitive Domain

Students will:

- observe and make discoveries.
- classify objects by multiple characteristics.
- make inferences and draw conclusions about stories they have heard.
- make a plan when doing an activity.
- order objects in sequence.
- play Brain Games to develop working memory and response inhibition.

Emotional/Personal Domain

Students will:

- make increasingly independent decisions.
- assume classroom chores independently.
- show increasing competence with self-care routines.
- follow classroom rules and routines.
- demonstrate confidence in their abilities.
- participate actively in classroom activities.
- indicate their feelings on the Feelings Thermometer.
- play Brain Games to develop working memory and response inhibition.

Language/Literacy Domain

Students will:

- participate in collaborative group conversations.
- identify book conventions.
- explore books independently.
- handle books carefully.
- make inferences and draw conclusions from stories.
- retell stories.
- identify initial phonemes in words.
- segment and count syllables.
- blend sounds to read words.
- discriminate visually between individual words and sentences in print.
- use increasingly complex vocabulary.
- use thematic vocabulary in conversations.
- demonstrate an awareness of the function of writing.
- demonstrate an interest in writing to communicate.
- recognize basic punctuation (periods, commas) and identify their meanings.

Mathematical Domain

Students will:

- compare and classify objects by length and height.
- measure objects using nonstandard units.
- identify and create a set that is more than or less than a given number.
- estimate and measure capacity.
- measure capacity with nonstandard units.
- count by 5s and 10s.
- estimate and weigh quantity.
- identify patterns.

Social Studies Domain

Students will:

- demonstrate an awareness of the roles people play in society.
- dramatize buying, selling, and manufacturing items.
- demonstrate an appreciation of and respect for differences in the customs of varying cultural groups.
- dramatize knowledge and use of currency in society.

Science Domain

Students will:

- predict outcomes.
- collect, describe, and record information through a variety of means.
- explore science tools to discover what they do.
- expand properties of seeds.
- use a scale and compare the weights of various objects.

Interpersonal Domain

Students will:

- give "I" Messages.
- participate in problem-solving scenarios.
- use active-listening skills.
- take turns and share.
- participate appropriately in cooperative activities.

Physical Domain

Students will:

- manipulate small objects with precision.
- throw, kick, or roll an object in an intended direction.
- catch a ball.
- play cooperative games.
- engage in gross-motor activities such as running or jumping.

Vocabulary

| Background Words | | | |
|------------------|-------------|------------|---------------|
| Food | Market | Dining | Picture Cards |
| bread | bagger | cafe | box |
| edible | baker | menu | chain |
| fat | bakery | restaurant | chair |
| fruit | basket | World | cherry |
| grain | butcher | globe | jacket |
| meat | buy | language | jam |
| milk | cart | map | quarter |
| oil | cashier | | quilt |
| sugar | deli | | six |
| treat | grocery | | van |
| vegetable | manager | | vegetables |
| | produce | | violin |
| | shelve | | yield |
| | shop | | yogurt |
| | supermarket | | |

Students will encounter background vocabulary words in natural ways throughout the unit. You will have a variety of opportunities to help students acquire these basic words that many students already know when they arrive in kindergarten.

| Theme-Related Words | |
|---------------------|--------------|
| aisle | job |
| checkout | nutrition |
| country | protein |
| customer | seeds |
| dairy | stand |
| department | stock person |
| energy | store |
| healthy | unhealthy |
| ingredients | |

The theme-related vocabulary words are explicitly taught each day. Encourage your students to use them whenever possible throughout the theme.

| Math Words | |
|-------------|--------------|
| bigger than | shorter than |
| less | shortest |
| longer than | smaller than |
| longest | sort |
| measure | tallest |
| more | |

Through Math Mysteries and 15-Minute Math activities, students will learn important mathematical vocabulary that will help them to communicate the new concepts that they are developing in math.



| STaR Words |
|------------|
| ached |
| develop |
| disguised |
| grocer |
| guarding |
| journey |
| list |
| revolting |
| stack |
| terrible |

STaR words help students to enrich their speaking vocabularies and increase their story comprehension.

Peek at the Week 1

| Lesson Component | Day 1 | Day 2 |
|------------------------------------------------------------------------------------------------------------------------|----------------------------------------------------------------------------------------|---------------------------------------------------------------------------------------------|
|  Greetings, Readings, & Writings | Arrival Activities | Arrival Activities |
|  Gathering Circle | Discuss how students respond to anger. Brain Game: Simon Says | Skill lesson: Stop and Stay Cool |
|  Theme Exploration | Healthy foods give us energy. | Learn about the role of grains in a nutritious diet. |
|  Rhyme Time | Listen to and recite "A Healthy Treat." Identify initial sounds. | "A Healthy Treat" Blend sounds to make words. |
|  STaR | <i>Gregory, the Terrible Eater</i> Focus: purpose for reading | Retell <i>Gregory, the Terrible Eater</i> with puppets. |
|  Dramatic Play Lab | KinderCorner Cafe: Role-play in an imaginary restaurant. | KinderCorner Cafe |
|  Blocks Lab | Build It!: Role-play in an imaginary construction site. | Food Delivery: Transport pretend food to the KinderCorner Cafe and pizza parlor. |
|  Art Lab | Creation Station: Freely create with open-ended materials. | Creation Station |
|  Classroom Library Lab | What's Cooking?: Explore recipe books. | What's Cooking? |
|  Literacy Lab | Play School: Role-play in an imaginary school. | Play School |
|  Math Lab | Bigger or Smaller? Sort and order objects by size. | Bigger or Smaller? |
|  Computer/Media Lab | Free Exploration: software, music, IWB activities | Free Exploration |
|  Sand/Water Lab | Free Exploration: Explore properties of sand and water. | Free Exploration |
|  Science Lab | Scientist's Station: Fruit Examination: Examine the inside of fruits to find seeds. | Scientist's Station: Grains Galore: Examine a variety of grains. |
|  Writing Lab | Menu Makers: Create menus for the imaginary restaurant and pizza parlor. | Healthy Helpings: Create food plates. |
|  15-Minute Math | Continue counting and number-awareness activities. | Continue counting and number-awareness activities. |
|  Snack • Outside • Gross-Motor Play | Play Bread, Bread, Fruit. | Serve a grain snack. Play Noodle. |
|  Stepping Stones | <i>Healthy Foods</i> Review "l"; text matching | Begin to recognize the sound and shape of "ch." Read <i>Healthy Foods</i> with partners. |
|  Math Mysteries | Sort objects by size. | Order objects by length. |
|  Let's Daydream | "A Circle of Sun" | "The Toaster" |
|  Write Away | Write about your favorite food. | Write about a kind of bread or cereal you eat for breakfast. |
|  Let's Think About It | Say complete sentences with food names. | <i>More Spaghetti, I Say!</i> |

| Day 3 | Day 4 | Day 5 |
|--------------------------------------------------------------------------------------------------------|---------------------------------------------------------------------------------------------------------|------------------------------------------------------------------------------|
| Arrival Activities | Arrival Activities | Arrival Activities |
| Skill lesson: Stop and Stay Cool | Review the Stop and Stay Cool steps. Play Simon Says. | Class Council |
| Learn about the role of fruits and vegetables in a nutritious diet. | Learn about the role of protein and dairy foods in a nutritious diet. | Fats, oils, and sugar are unhealthy if eaten in excess. |
| "A Healthy Treat" Segment the sounds in spoken words. | "A Healthy Treat" Recognize alliteration. | "A Healthy Treat" Blend onsets and rimes of single-syllable spoken words. |
| <i>The Little Mouse, the Ripe Red Strawberry, and the Big Hungry Bear.</i> Focus: Make predictions. | Retell <i>The Little Mouse, the Ripe Red Strawberry, and the Big Hungry Bear</i> with sequencing cards. | Free-Choice Story Time |
| KinderCorner Cafe | KinderCorner Cafe | KinderCorner Cafe |
| Food Delivery | Food Delivery | Food Delivery |
| Still Life Still life paintings with fruit | Still Life | Still Life |
| What's Cooking? | What's Cooking? | What's Cooking? |
| Play School: Letter Sounds Soup | Play School: Letter Sounds Soup | Play School: Letter Sounds Soup |
| Bigger or Smaller? | Bigger or Smaller? | How Big Is It? Measure objects with a Crayon Tape Measure |
| Free Exploration | Free Exploration | Free Exploration |
| Harvesting Vegetables | Harvesting Vegetables | Harvesting Vegetables |
| Scientist's Station: Seed Study: Examine the inside of fruits and vegetables to find seeds. | Scientist's Station: Seed Study: Examine seeds. | Scientist's Station: Seed Study |
| Healthy Helpings | Healthy Helpings | Healthy Helpings |
| Introduce concept of shorter than/longer than a foot. | Continue counting and number-awareness activities. | Continue counting and number-awareness activities. |
| Serve a fruit or vegetable snack. Play kickball. | Serve a protein or dairy snack. Play a beanbag-toss game. | Serve fruit salad. Free-choice game or unstructured play |
| Begin to recognize the sound and shape of "j." <i>Fruit Salad</i> Review "we"; sound out "cut." | Begin to recognize the sound and shape of "v." Read <i>Fruit Salad</i> with partners. | Review /ch/, /j/, and /v/. Free choice with a concepts-of-print book |
| Order objects by height | Measure length with nonstandard units. | Measure length with nonstandard units. |
| "Tutti Frutti Lovesong" | "The Gentle Cow" | "A Good Place to Sleep" |
| Write about a kind of fruit or vegetable you eat with your lunch. | Write about a kind of dairy or protein you eat for dinner. | Add a sentence to one written on days 1–4. |
| Play Nutrition Lotto. | Play Nutrition Lotto. | Play Simon Says with food groups. |

Peek at the Week 2



| Lesson Component | Day 6 | Day 7 |
|------------------------------------------------------------------------------------------------------------------------|------------------------------------------------------------------------------------------------------------------|--------------------------------------------------------------------------------------------|
|  Greetings, Readings, & Writings | Arrival Activities | Arrival Activities |
|  Gathering Circle | Skill lesson: Stop and Stay Cool Brain Game: Going to the Market | Skill lesson: Stop and Stay Cool |
|  Theme Exploration | Discuss characteristics of food markets. | Classify foods by grocery store departments. |
|  Rhyme Time | Listen to and recite "Food for You and Me." Count syllables. | "Food for You and Me" Blend sounds to make words. |
|  STaR | <i>Bunny Cakes</i> Focus: Relate story plot to reality. | Retell <i>Bunny Cakes</i> through dramatization. |
|  Dramatic Play Lab | KinderCorner Market: Role-play in an imaginary grocery store. | KinderCorner Market |
|  Blocks Lab | Off to the Market: Transport pretend food to the grocery store. | Off to the Market |
|  Art Lab | Shopping Bags: Decorate bags for the grocery store. | Shopping Bags |
|  Classroom Library Lab | Free Reading: Explore self-selected books. | Free Reading |
|  Literacy Lab | Play School: Role-play in an imaginary school. | Play School |
|  Math Lab | The Right Price: Create price tags for the imaginary grocery store. | The Right Price |
|  Computer/Media Lab | Free Exploration: software, music, IWB activities | Free Exploration |
|  Sand/Water Lab | Free Exploration: properties of sand and water | Fill 'er Up: Fill containers. |
|  Science Lab | Nutrition Lotto | Nutrition Lotto |
|  Writing Lab | Make a List, Please: Grocery lists | Make a List, Please |
|  15-Minute Math | Continue counting and number-awareness activities. | Continue counting and number-awareness activities. |
|  Snack • Outside • Gross-Motor Play | Play To Market, To Market. | Vegetable tasting Play Hot Potato. |
|  Stepping Stones | <i>At the Market</i> Introduce the sight word "you"; review "the." Sound out "at" and "can"; text matching | Begin to recognize the sound and shape of "y." Read <i>At the Market</i> with partners. |
|  Math Mysteries | Identify a set that is more. | Identify a set that is less. |
|  Let's Daydream | "The Noise of Nothing" | "Cats" |
|  Write Away | Write a shopping list to take to the market. | Write about things you would find at the market. |
|  Let's Think About It | Write a letter of inquiry to a grocery store. | Classify foods by grocery store departments. |

| Day 8 | Day 9 | Day 10 |
|--------------------------------------------------------------------------------------------------------------------------|-----------------------------------------------------------------------------------------|------------------------------------------------------------------------|
| Arrival Activities | Arrival Activities | Arrival Activities |
| Skill lesson: Stop and Stay Cool | Stop and Stay Cool Play Going to the Market. | Class Council |
| Learn about markets in different parts of the world. | Learn about the various types of jobs available in markets. | Learn about different types of markets. |
| "Food for You and Me" Segment sounds in spoken words. | "Food for You and Me" Identify initial sounds. | "Food for You and Me" Count syllables. |
| <i>Tap-Tap</i> Focus: Summarization | Retell <i>Tap-Tap</i> through summarization. | Free Choice |
| KinderCorner Market | KinderCorner Market | KinderCorner Market |
| Off to the Market | Off to the Market | Off to the Market |
| Shopping Bags | Shopping Bags | Shopping Bags |
| Free Reading | Free Reading | Free Reading |
| Play School: Yellow Yo-Yo | Play School: Quilted "q"s | Play School: Quilted "q"s |
| The Right Price | The Right Price | The Right Price |
| Free Exploration | Free Exploration | Free Exploration |
| Fill 'er Up | Fill 'er Up | Fill 'er Up |
| Which Weighs More? | Which Weighs More? | Which Weighs More? |
| Make a List, Please | Market Sales | Market Sales |
| Introduce Two More and Two Less. | Continue counting and number-awareness activities. | Introduce What Holds More? |
| Serve foods from various cultures. Free-choice game or unstructured play | Serve fruit. Free-choice game or unstructured play | Serve a variety of foods. Play Duck, Duck, Goose, Goose. |
| Begin to recognize the sound and shape of "q." <i>Lunch Time</i> Review "a"; use picture clues and initial sounds. | Begin to recognize the sound and shape of "x." Read <i>Lunch Time</i> with partners. | Review /y/, /q/, and /x/. Free choice with a concepts-of-print book |
| Create sets that are more and less. | Measure capacity with nonstandard units. | Estimate and measure capacity. |
| "For Sale" | "Big Sister" | "The Click Clacker Machine" |
| Write about what you will buy at the market for dinner. | Write about food you would see at one type of market. | Add a sentence to one written on days 6–9. |
| Practice complete sentences with a food purchase. | Market-job pantomime game | Supermarket-facts game |

You Will Need

Supplied by SFAF:



| Books | STaR |
|---------|------------------------------------------------------------------------------------------------------------------------------------------------------------------------------------------------------------------------------------------------------------------------------------------------------------------|
| | <p><i>Gregory, the Terrible Eater</i> by Mitchell Sharmat</p> <p><i>The Little Mouse, the Red Ripe Strawberry, and the Big Hungry Bear</i> by Don and Audrey Wood</p> <p><i>Bunny Cakes</i> by Rosemary Wells</p> <p><i>Tap-Tap</i> by Karen Lynn Williams</p> |
| | Concepts of Print |
| | <p><i>Healthy Foods</i> by Sally Francis Anderson (SFAF) teacher and student copies</p> <p><i>Fruit Salad</i> by Barbara Wasik (SFAF) student copies</p> <p><i>At the Market</i> by Sally Francis Anderson (SFAF) teacher and student copies</p> <p><i>Lunch Time</i> by Barbara Wasik (SFAF) student copies</p> |
| | Other |
| | <p><i>The 20th Century Children's Poetry Treasury</i> by Jack Prelutsky</p> <p><i>More Spaghetti, I Say!</i> by Rita Golden Gelman</p> <p><i>Child-size Masterpieces for Steps 1, 2, 3</i> by Aline Wolf</p> |
| Media | |
| | <p>KinderCorner 2nd Edition Plus Media and Software flash drive</p> <p>KinderCorner 2nd Edition Plus Home Link show for unit 6</p> |
| | Cards/Card Sets |
| | KinderCorner Phonics Picture Cards |
| | <p>Key cards: "ch," "j," "q," "v," "x," and "y"</p> <p>Uppercase and Lowercase Letter Cards: "Jj," "Vv," "Qq," and "Xx"</p> <p>Picture cards: chain, chair, cherry, jacket, jam, van, vegetables, violin, yield, yogurt, quarter, quilt, box, six</p> |
| | Other |
| | <p>Letter-Blending Cards: "a," "b," "ch," "e," "i," "j," "m," "n," "o," "p," "qu," "s," "sh," "t," "u," "v," "w," "x," and "y"</p> <p>Nutrition Lotto Picture Cards</p> |
| Posters | |
| | <p>Stop and Stay Cool Steps poster*</p> <p>USDA MyPlate poster</p> |

| Math Kit Items | |
|------------------------------------------------------------------------------------|-----------------------------------------------------------------------------------------------------------------------------------------------------------------------------------------------------------------------------------------------------------------------------------------------------------------------------------------------------------------------------------------------------------------------------------------------------------------------------------------------|
|  | <p>Number Cards</p> <p>Transparent spinners</p> <p>Dot-Set Recognition Cards</p> <p>Two cutouts of a foot</p> <p>Shorter Than/Longer Than a Foot poster</p> |
| Other SFAF Items | |
|  | <p>KinderCorner Weekly Record Form for unit 6, weeks 1 and 2 (generate with online data tools)</p> <p>Cool Kid certificates (four)</p> <p>Puppets: KinderRoo, Joey, and Alex</p> <p>Read & Respond bookmarks</p> <p>Stepping Stones Partner Practice Booklet for unit 6</p> <p>Transparent color counting chips (for pocket points)</p> <p><i>Writing Development Feedback Guide (KinderCorner 2nd Edition Plus Teacher's Manual)</i></p> <p>Home Link animal hand stamps and ink pad</p> |

*Interactive-whiteboard users do not need to gather this material.

Teacher Acquired:

Teacher's Note: Be sure to check for any food allergies among students in your classroom before serving or exploring any food. Common allergens include nuts, gluten, wheat, corn, and strawberries.

| Food | | |
|------------------------------------------------------------------------------------|-----------------------------------------------------------------------------------------------------------------------------------------------------------------------------------------------------------------------------------------------------|-----------------------------------------------------------------------------------------------------------------------------------------------------------------------------------------------------------------------------------------------------------------------|
|  | <p>For Rhyme Time, day 1 (optional)</p> <p>Samples for the poem: Raspberries, raisins, rice, mushrooms, milk, meat, carrots, corn, cabbage, cauliflower, peaches, pears, plums, bread, butter, and milk</p> | <p>For Snack</p> <p>Fruits, vegetables, or other food from <i>Gregory, the Terrible Eater</i></p> <p>Muffins, crackers, bagels or other snacks made from grains</p> <p>Dairy or protein foods</p> <p>A variety of breads that represent different cultures</p> |
| Office/Craft Supplies | | |
|  | <p>Red and green markers (one each)</p> <p>Three-by-five-inch index cards</p> <p>Ball, box, cube, and can shapes</p> <p>Magazine pages with food items on them, primarily of dairy and protein</p> <p>Grocery bag</p> <p>Pictures of food items</p> | <p>Small plastic bags</p> <p>Red, yellow, green, and orange paper</p> <p>Poster board</p> <p>Chart paper</p> <p>Paper lunch sacks for making puppets (one per student)</p> |

*Interactive-whiteboard users do not need to gather these items.

To Be Prepared:

| Day 1 | |
|-------------|---------------------------------------------------------------------------------------------------------------------------------------------------------------------------------------------------------------------------------------------------------------------------------------------------------------------------------------------------------------------------------------------------------------------------------------------------------------|
| TE | <ul style="list-style-type: none"> • Make theme vocabulary word cards for “healthy” and “energy.”* |
| STaR | <ul style="list-style-type: none"> • Number the pages of <i>Gregory, the Terrible Eater</i>; page 1 begins, “Once there was a goat named Gregory.” |
| LL | <ul style="list-style-type: none"> • Create a board for the writing lab that says “Today’s Special” by laminating a large piece of construction paper. Students can add today’s special menu item to the board for the customers to order. |
| SS | <ul style="list-style-type: none"> • Duplicate the <i>Healthy Foods</i> word cards. You will need enough copies for each partnership to have one word. (Multiple partnerships may have the same word.) |
| MM | <ul style="list-style-type: none"> • Create a large sorting mat by drawing two large circles on a piece of bulletin board paper. • Duplicate the Sort-by-Size Workmat page (appendix), one per student. • Place ten objects of various sizes from the classroom in a plastic bag, one bag per partnership. Some of the objects should be larger than the paintbrush on the Sort-by-Size Workmat, and some should be smaller. |
| LTAI | <ul style="list-style-type: none"> • Duplicate theme-introduction letter for unit 6, one per student (appendix). |
| Day 2 | |
| GC | <ul style="list-style-type: none"> • Duplicate the Chilly the Penguin Puppet page, one per student (appendix). • Make your own Chilly the Penguin puppet for demonstration. |
| TE | <ul style="list-style-type: none"> • Make theme vocabulary word cards for “nutrition” and “ingredients.”* |
| STaR | <ul style="list-style-type: none"> • Duplicate the <i>Gregory, the Terrible Eater</i> puppets, one per group of four students (appendix). |
| LL | <ul style="list-style-type: none"> • Duplicate the USDA MyPlate Graphic page, one copy per student, and place them in the writing lab (appendix). |
| MM | <ul style="list-style-type: none"> • Place the following items into a box: one long blue pencil, one medium-sized red pencil, and one shorter green pencil. • Place three crayons, pencils, paintbrushes, or markers of different lengths in a small plastic bag, one bag per partnership. |
| Day 3 | |
| TE | <ul style="list-style-type: none"> • Place the Nutrition Lotto game pieces, plastic food, or real fruit and vegetables in a grocery bag. • Make a theme vocabulary word card for “seeds.”* |
| STaR | <ul style="list-style-type: none"> • Number the pages of <i>The Little Mouse, the Ripe Red Strawberry, and the Big Hungry Bear</i>; page 1 begins, “Hello, little mouse.” |
| MM | <ul style="list-style-type: none"> • Duplicate the Who Is the Tallest? sheet (appendix), one per partnership. |

| Day 4 | |
|-------------|---------------------------------------------------------------------------------------------------------------------------------------------------------------------------------------------------------------------------------------------------------------------------------------------------------------------------------------------|
| TE | <ul style="list-style-type: none"> • Make theme vocabulary word cards for “dairy” and “protein.”* • Place the Nutrition Lotto, dramatic play, or real dairy and protein items in a grocery bag. |
| STaR | <ul style="list-style-type: none"> • Duplicate <i>The Little Mouse, the Ripe Red Strawberry, and the Big Hungry Bear</i> Sequencing Cards, one per group of four or five students (appendix). |
| MM | <ul style="list-style-type: none"> • Duplicate the Crayon Tape Measure page (appendix), one per partnership. Cut along the dotted lines, and glue the segments into one long strip to form each tape measure. • Duplicate the Body Measurement Sheet (appendix), one per student. |
| Day 5 | |
| TE | <ul style="list-style-type: none"> • Make a theme vocabulary word card for “unhealthy.”* |
| MM | <ul style="list-style-type: none"> • Fill plastic bags with thirty to forty linking cubes each, one bag per partnership. Each partnership will measure a book, backpack, desk, and block. Have these materials readily available in the classroom. • Duplicate the Let’s Measure Sheet (appendix), one per student. |
| Day 6 | |
| TE | <ul style="list-style-type: none"> • Make theme vocabulary word cards for “aisle” and “checkout.”* |
| RT | <ul style="list-style-type: none"> • Gather pictures of food items that the students should be familiar with. Place these pictures in a box, basket, or grocery bag. If possible, use real objects instead. |
| STaR | <ul style="list-style-type: none"> • Number the pages of <i>Bunny Cakes</i>; page 1 begins, “It was Grandma’s birthday.” |
| SS | <ul style="list-style-type: none"> • Duplicate the <i>At the Market</i> Word-and-Picture Matching Cards, one per partnership (appendix). |
| MM | <ul style="list-style-type: none"> • Make two large circles on the floor with yarn or masking tape. These circles will remain on the floor through day 2. • Duplicate the Circle Workmat page (appendix), one per student. • Fill small plastic bags with twelve linking cubes each, one bag per student. |
| Day 7 | |
| GC | <ul style="list-style-type: none"> • Duplicate the Joey and Alex Stick Puppets, one per student (appendix). |
| TE | <ul style="list-style-type: none"> • Make theme vocabulary word cards for “customer” and “department.”* • Fill a grocery bag with food from the dramatic play lab and/or the Nutrition Lotto cards. |
| MM | <ul style="list-style-type: none"> • Fill small plastic bags with twelve linking cubes each, one bag per partnership. |
| LTAI | <ul style="list-style-type: none"> • Duplicate the Grocery Store Spinner (appendix), and attach it to the transparent spinner. |

| Day 8 | |
|--------------|----------------------------------------------------------------------------------------------------------------------------------------------------------------------------------------------------------------------------------------------------------------------------------------------------------------------------------------------------------|
| TE | • Make a theme vocabulary word card for “country.”* |
| LL | • Duplicate the Yellow Yo-Yo “y” Pattern sheet, one per student (appendix). |
| MM | • Fill small plastic bags with twelve linking cubes each, one bag per student. • Duplicate the Ten-Frame Workmat page (appendix), one per student. • Duplicate the 2–9 Spinner page (appendix) and the More-or-Less Spinner page (appendix). Cut the spinners out, and attach each to one transparent spinner. |
| LTAI | • Label index cards with letters that begin the name of common supermarket products, one card per partnership. |
| Day 9 | |
| TE | • Make theme vocabulary word cards for “job” and “stock person.”* |
| RT | • Prepare index cards with the letters “b,” “f,” and “w” written on them (one letter per card). There should be enough cards for each student to have one. |
| LL | • Duplicate the Quilting “q” Pattern sheet, one per student (appendix). |
| MM | • Fill small plastic bags with twenty linking cubes each, one bag per partnership. |
| Day 10 | |
| TE | • Make theme vocabulary word cards for “store” and “stand.”* |
| | • Label sheets of construction paper with one of the following terms each: “produce stand,” “bakery,” “dairy department,” “deli,” and “candy store.” Add small drawings to each paper to help students identify the supermarket department written on the card. |
| | • Fill a grocery bag with food items (from the Nutrition Lotto game, dramatic play lab, etc.) that would be found in each of the departments indicated the labeled sheets. |
| 15-MM | • Attach the What Holds More? poster to the 15-Minute Math bulletin board. • Collect eight to ten containers of various sizes (e.g., a cracker box, an oatmeal canister, a margarine tub, a butter box). Label each container with a different letter starting with “A.” Place the containers near the 15-Minute Math area. |
| MM | • Fill two containers with linking cubes. Use a self-stick note to label the number of cubes in each container. • Create small plastic bags with ten to thirty of each of the following: bear counters, bicolored counters, buttons, and beads; one bag per partnership. • Duplicate the How Many Will It Hold? sheet (appendix), one per student. |

*Interactive-whiteboard users do not need to prepare this material.

Day 1 | Ready, Set...

Focus

Our bodies need healthy food for energy, to make us grow, and to keep us well.

| Materials | |
|--------------------------------------------|-------------------------------------------------------------------------------------------------------------------------------------------------------------------------------------------------------------------------------------------------------------------------------------------------------------------------------------------------------------------------------------------------------------------------------------------------------------------------------------------------------------------------------------------------------------------------------------------------------------------------------------------------------------------------------------------------------|
| Greetings, Readings, & Writings | <ul style="list-style-type: none"> • Weekly record form for unit 6—week 1 • Sign-in sheets that include only lines for students to write their names on • Classroom Library Lab: STaR books and other books provided for unit 6, theme-related books about nutrition • Literacy Lab: Materials for tactile letter activities, such as zipper-closure baggies filled with hair gel, cookie sheets covered in a thin layer of sand, etc., and key cards for “sh,” “z,” and “w” • Math Lab: Multilink cubes • Writing Lab: A variety of writing instruments and paper, students’ writing journals • Theme-related puzzles and games |
| Gathering Circle | <ul style="list-style-type: none"> • None |
| Theme Exploration | <ul style="list-style-type: none"> • KinderRoo, Joey, and Alex puppets • Nutrition Lotto game pieces in a grocery bag • Theme vocabulary word cards for “healthy” and “energy” or IWB access |
| Rhyme Time | <ul style="list-style-type: none"> • KinderCorner 2nd Edition Plus Media and Software flash drive • Food items mentioned in the rhyme “A Healthy Treat” (optional) |
| STaR | <ul style="list-style-type: none"> • Trade book: <i>Gregory, the Terrible Eater</i> |
| 15-Minute Math | <ul style="list-style-type: none"> • No new materials |
| Snack/Outside/ Gross-Motor Play | <ul style="list-style-type: none"> • Fruits, vegetables, or other food from <i>Gregory, the Terrible Eater</i> |
| Stepping Stones | <ul style="list-style-type: none"> • Concepts-of-print book (teacher and student copies): <i>Healthy Foods</i> • <i>Healthy Foods</i> word cards (appendix) |

| Materials | |
|-----------------------------|--------------------------------------------------------------------------------------------------------------------------------------------------------------------------------------------------------------------------------------------------------------------------------------------------------------------------------------------------------------------------------------------------------------------------------------------------------------------------------------------------------------------------------------|
| Math Mysteries | <ul style="list-style-type: none"> • KinderRoo and Joey puppets • Several objects from the classroom (Some of the objects should be larger than KinderRoo, and some should be smaller.); place objects in large box. • Large sorting mat • Bags of objects from the classroom (Some of the objects should be larger than the paintbrush on the Sort-by-Size Workmat, and some should be smaller.); one bag per partnership • Sort-by-Size Workmat (appendix), one per partnership |
| Let's Daydream | <ul style="list-style-type: none"> • "A Circle of Sun," <i>The 20th Century Children's Poetry Treasury</i>, page 4 |
| Write Away | <ul style="list-style-type: none"> • Journals, pencils, place to write for teacher modeling • <i>Writing Development Feedback Guide</i> • Writing Strategies Bank or IWB access |
| Let's Think About It | <ul style="list-style-type: none"> • Trade book: <i>Gregory, the Terrible Eater</i> • Nutrition Lotto boards and pieces • Grocery bag • Theme-introduction letter for unit 6 (appendix), one per student • Read & Respond forms • Home Link animal hand stamp: parrot |

Learning Labs—Materials

Dramatic Play Lab | KinderCorner Cafe

- Apron(s)
- Chef's hat (optional)
- Dishes
- Napkins
- Order pads
- Cash register
- Pencils
- Place mats
- Plastic foods or foods created by students
- Play money
- Recipes
- Serving tray
- Tablecloth
- Utensils
- Boxes
- Construction paper
- Scissors
- Tape
- Markers or crayons

Teacher's Note: Some props, such as the cash register or play money, can be created by students.

Blocks Lab | Build It!

- Wooden and/or cardboard blocks; block play figures such as people, animals, traffic signs, or vehicles; toy dump trucks and bulldozers; construction hard hats

Art Lab | Creation Station

- Open-ended materials, such as construction paper, wrapping paper, glue, scissors, paint, paintbrushes, an easel, smocks, yarn, sequins, markers, crayons, etc., that students can use to create art pieces

Classroom Library Lab | What's Cooking?

- Cookbooks
- Recipes from magazines (enlarged and laminated if possible)

Literacy Lab | Play School

- A chalkboard and chalk, whiteboard and marker, or chart paper and a marker for the pretend teacher; books, letter cards, magnetic letters, paper and pencils, letter stamps and ink pads, or any other items that students could use to play school

Math Lab | Bigger or Smaller?

- Art supplies (e.g., paintbrushes, tubes of paint, pencils, crayons, markers, paper, scissors, etc.)
- Wonder Box

Computer/Media Lab | Free Exploration

- Computers, tape recorders, digital tablets, or other electronic media that you may have; software, applications, or CDs to accompany the media

Sand/Water Lab | Free Exploration

- Sand and water play tools—measuring cups and spoons, funnels, buckets, scoops, and plastic jars and bottles in a variety of shapes and sizes

Science Lab | Scientist's Station: Fruit Examination

- Examination tools—magnifying glasses, balance scale, tape measure
- Variety of foods that contain seeds (apple, pear, bell peppers, squash, etc.)

Teacher's Note: Many foods are referred to as vegetables in our culture, but from a scientific standpoint, they are actually fruits. From a scientific standpoint, fruits contain seeds, and vegetables do not.

Writing Lab | Menu Makers

- Variety of writing instruments (pens, pencils, crayons, markers) and things to write on (various types of lined and unlined paper, drawing paper, mini chalkboards or whiteboards, journals, etc.)
- Laminated Today's Special sign or a mini chalkboard and chalk or a mini whiteboard and dry-erase marker (chalkboard or whiteboard should be labeled "Today's Special")
- Sample menus

Day 1

**Greetings, Readings,
& Writings**

TIMING GOAL: 15 minutes

| Student Routines | Teacher Routines |
|-------------------------------------------------------------------------------------------------------------------------------------------------------------------------|----------------------------------------------------------------------------------------------------------------------------------------------------------------------------------------------------------------------------------------------------------------------------------------------------------------------------------------------------------------------------------------------------------------------------------------------------------|
| <ol style="list-style-type: none"> 1. Remove coats and backpacks. 2. Turn in homework. 3. Sign in. 4. Self-select activities. | <ol style="list-style-type: none"> 1. Greet parents and students. 2. Remind students to read the Arrival Activities poster as they prepare for their day. 3. Encourage students to describe what they are doing in full sentences as you observe their activities. 4. Observe for student progress with their individualized objectives from the weekly record form. Circle demonstrated skills if applicable. |

Homework

- Read & Respond

Sign In

- The sign-in sheet today will only include lines. Encourage students who have not yet learned to write their names to use emergent-writing strategies that you have introduced.

Available Activities

Classroom Library Lab

- Include new theme-related books about nutrition.
- Have the ear and mouth cards available. Encourage pairs of students to use the partner reading routine as they explore the books.

Literacy Lab

- Place the key cards for “sh,” “z,” and “w” in the lab so students will be encouraged to use the tactile letter-formation materials to practice their letter formation.

Math Lab

- Encourage students to make patterns with the multilink cubes.

Computer/Media Lab

- Let students know that the computer/media lab is open. Turn on the computers if necessary.

Writing Lab

- Have a variety of writing instruments (crayons, markers, pencils) and types of writing paper (lined, unlined, construction) available. Students' writing journals should also be easily accessible.
- Allow students to freely write whatever they want.

Other

- If you have any theme-related puzzles or games, make them available.



Sing a transitional gathering song. Encourage students to sing along as they move to the gathering area.

Gathering Circle

TIMING GOAL: 15 minutes

Routine

1. Welcome students to the Gathering Circle.
2. Check attendance.
3. Discuss yesterday's homework assignment. Award pocket points if at least half the students completed their homework.
4. Assign classroom jobs for the week.
5. Assign partnerships for the week. Have students move to sit with their partners.
6. Select this week's first Cool Kid.

Partner Challenge

- Explain the challenge.

Everyone has angry feelings at times. When we get angry with our friends, we can end up having problems or conflicts. What do you do when you feel angry? Our Partner Challenge today is to tell your partner what you do when you get angry.

- Provide a moment for students to think about the challenge. Remind them that they will have time to talk with their partners about the Partner Challenge at snack time.
- Tell students they will earn pocket points when they use active-listening skills while they talk with their partners.

Brain Game

- Explain the game.

We play our Brain Games to help us exercise our mind muscles. Our game this week is Simon Says. Simon Says helps us to stop and think.

Give the Stop and Think signal (one hand held out like a stop sign while the other points to head).

- If students aren't familiar with this game, explain that in this game, when the leader says, "Simon says," to do something, they must do what he or she says. If the leader doesn't say, "Simon says," before giving a direction, they don't do it. Initially, you will be Simon, and as students become familiar with the game, they can take turns being Simon.
- Play the game now, demonstrating the actions that Simon tells students to do. Once students understand that they do not follow the direction if it's not preceded by the words "Simon says," demonstrate all the actions to trick students.

Theme Exploration

TIMING GOAL: 15 minutes

Partnership Question of the Day



We are starting a new unit today about something lots of people like... food! Think about your favorite foods. T-P-S: What do you like to eat?

Our Daily Message will tell us something very important about food.

Daily Message

Our bodies need healthy food for energy, to make us grow, and to keep us well.

- Write the Daily Message in front of students, reading each word as you finish writing it. Then read the entire message again, touching each word as you read it.
- Reinforce literacy objectives by pointing out the following:
 - **This sentence has some little marks inside of it that are not periods.** Point to each comma in the Daily Message. **What are these marks called?** *Commas.*
 - **This sentence tells us three different things about why we need healthy food.** Underline the three different ideas. **The commas go in between the three ways that food helps our bodies. Watch for commas when you are looking at books.**



Theme Learning



- Explain the content of the Daily Message.

Our Daily Message tells us that our bodies need healthy food. Healthy food gives us energy, helps us grow, and keeps us well. T-P-S: What are some foods that you think are healthy foods? Answers will vary. I heard some good ideas! Foods such as fruits and vegetables are healthy foods.

- Bring out KinderRoo, Joey, and the grocery bag.

KinderRoo and Joey went shopping at the food store this weekend. Let's find out what foods they bought at the store. In a moment, I'm going to bring the grocery bag around and let one person from each partnership select an item from the bag. When you select an item from the bag, I would like you to look at it carefully. You and your partner are going to talk about the food and tell us about it. You will think about these questions: Do you know the name of your food? Have you ever eaten it before?

- Allow one student from each partnership to select an item from the bag. Give students time to look at the item and then tell about it.



- Use the sharing sticks to select students to share their responses with the class. Encourage students to state their ideas in complete sentences. As students share, collect their food items, but do not return them to the grocery bag. Award pocket points if several students are able to successfully express their ideas in complete sentences.
- Engage KinderRoo in the conversation as you continue to discover the foods in her grocery bag.

There is still more food in KinderRoo's grocery bag! If we want to ask KinderRoo and Joey what they bought at the store, we might look at KinderRoo and ask the question like this, "KinderRoo, what foods did you buy at the store?"

Let's practice asking KinderRoo our question and listening to her answer. Model how to ask the first question. KinderRoo, what other foods did you buy at the store? Have KinderRoo say, If you help me take the items from my grocery bag, then I will tell you what I bought. Pull one item from the grocery bag, and place it in front of KinderRoo where all students can see it. Then have KinderRoo say, I bought a(n) (food item) at the store.

- Invite students to take turns asking KinderRoo what she bought, selecting an item from the bag, and then listening to her answer. Repeat this activity until all the items have been named.
- After all the items have been named and returned to the grocery bag, place KinderRoo on one hand, and place the Alex puppet on your other hand. Make KinderRoo jump and move as if she has lots of energy, and make Alex act sluggish and hang his head. Then engage the puppets in the following conversation.

As teacher: **Oh! KinderRoo, you certainly bought a lot of food for Joey and yourself, but I have another question to ask you. Why did you buy so many kinds of foods?**

As KinderRoo: **Joey and I need lots of different kinds of foods to keep us strong and healthy and to give us energy to play and learn just like you!**

As teacher: **KinderRoo, you do look like you have lots of energy. I think you've been eating lots of healthy food. Alex, you look like you don't feel very well. What's wrong?**

As Alex: **No, I don't feel well. I think it might be because of my breakfast. All I had was a bag of candy and some potato chips.**

As teacher: **Candy and potato chips? That's not a very healthy breakfast, Alex! How are you feeling? It looks like you don't have much energy.**

As Alex: **No, I don't have any energy. I was supposed to have a soccer game this morning, but all I want to do is stay in bed. I think I'd better eat something healthier for lunch.**

As teacher: **Good idea, Alex! Maybe KinderRoo can give you some ideas about what foods you should eat.**



- Play the digital dictionary videos for “healthy” and “energy.”
- Re-emphasize the theme-related vocabulary words. Post the words, or point to them on the interactive whiteboard, as you discuss each one.

Our two new words for today are “healthy” and “energy.”

Our Daily Message told us about healthy foods. If something is healthy, it means that it is good for you. We will learn about different kinds of healthy foods each day this week. I can make a sentence with the word “healthy.”

I bought healthy food to eat at the grocery store.

We said that healthy food gives us energy. Energy is what makes you feel like moving. When you are running, you have lots of energy. Sometimes when we don't feel well, we don't have a lot of energy. We just want to rest. I can make a sentence with the word “energy.”

Energy helps me jump rope for a long time without stopping.

Let's use our energy to get ready for Rhyme Time!



Ask students to stand up as they sing “It's Time for a Rhyme” to signal the transition to Rhyme Time.

Rhyme Time

TIMING GOAL: 10 minutes

Say the Rhyme

- Introduce the rhyme “A Healthy Treat.”

Today we will begin to learn a new rhyme about some healthy foods we can eat. We'll learn and say this chant over the next few days as we think about the foods that help our bodies stay strong and healthy. There are many foods mentioned in this rhyme. Listen carefully, and see how many you recognize.



- Start the video to hear the audio and see the hand motions, or read the words and model the motions.
- Use My Turn, Your Turn to teach the rhyme to students, one line at a time.

Remember that memorization skills come easier to some than to others, and this is a lengthier rhyme than usual. It is not necessary for students to memorize the rhyme, although some may be able to do so since it will be repeated throughout the entire week and reciting it aloud makes it easier to learn.

A Healthy Treat

To keep our bodies growing strong (Hold arms to side and make muscles.)

There are foods we need to eat—(Continue same motion.)

Raspberries, raisins, and some rice, (Rub stomach.)

Or mushrooms, milk, and meat. (Rub stomach.)

Carrots, corn, and cabbage mixed (Pretend to pull vegetables from the ground.)

With cauliflower, too, (Continue same motion.)

Cut up fine, cooked in a wok (Pretend to chop vegetables.)

A healthy meal for you. (Point with one finger.)

Take some peaches and some pears, (Pretend to pick fruit from a tree.)

Perhaps a plum or two, (Continue same motion.)

Put them in a pastry shell (Pretend to put fruit in a pie.)

There's a perfect pie for you. (Extend arms out in front, palms up, as if serving a pie.)

Sometimes bread and butter will do; (Pretend to butter a slice of bread.)

Sometimes milk and meat. (Pretend to pour a glass of milk.)

Put them all together (Bring hands together.)

And you'll have a healthy treat! (Extend arms out to either side, palms up, elbows bent.)

Develop Phonological Awareness—Identifying Initial Sounds



- Recite the rhyme again, asking students to listen for the rhyming words in the first two stanzas. Slowly say the first stanza, emphasizing the rhyming words “eat” and “meat” in the second and fourth lines. T-P-S: **What rhyming words did you hear in that part of the rhyme?**
- Continue to read the next stanza, inviting students to listen for the rhyming words.
T-P-S: **Try to remember one food that was named in the rhyme, and then tell your partner.**
- Prompt students to say the name of the food again quietly in their heads, concentrating on the initial sound of the word.

Say the name of the food again quietly in your head. As you say the name of the food, think about its beginning sound.

- Model how to say a word quietly to yourself and think about the beginning sound. You might close your eyes and mouth the word that you are thinking about to show students what this process looks like. (For example, close your eyes, and mouth the word “carrot”—/c/, /c/, carrot.) Pause for students to think about and mouth their words.
- Have students share their words and the words’ beginning sounds with their partners.
- Ask students to think of another word that begins with the same sound as the food that each of them named and to share it with their partners.
- Use the sharing sticks to select one or two partnerships to share their words. Have the class repeat the words and the beginning sound of each word in isolation (e.g., *butter*, /b/, /b/, *butter*; *bananas*, /b/, /b/, *bananas*.) Award pocket points if several students are able to successfully produce words with the requested initial sound.



Sing the song “Let’s Read Together” with students.



TIMING GOAL: 20 minutes

STaR Words:

terrible
 revolting
 develop

Gregory, the Terrible Eater

Written by Mitchell Sharmat

Illustrated by Jose Aruego and Ariane Dewey

Gregory is no ordinary goat. In fact, he is so extraordinary that his mother and father bring him to the doctor to find out why he won't eat boxes, cans, and pants like other goats. Gregory prefers what his parents call "junk food" such as eggs, orange juice, cereal, and such. In this silly story, Gregory learns a lesson about trying new foods, but it is a lesson that goes too far.

Interactive Story Reading

Before Reading

- Introduce the title, author, and illustrator of the story. Have students identify the author's and illustrator's roles and the purpose of the title.



The title of our story today is *Gregory, the Terrible Eater*. WGR: What does the title of a story tell us? *The name of the story.* The author of the story is Mitchell Sharmat. WGR: What job does the author of a story do? *Writes the words.* There are two illustrators for this story. Their names are Jose Aruego and Ariane Dewey. WGR: What did these two people do? *Drew or painted the pictures.*



- Have students preview the story. Guide them as they make predictions about the story based on the cover illustration and the title.

Point to the four thought bubbles that illustrate what Gregory is thinking about. **These pictures show what Gregory is thinking about. He is thinking about carrots, fish, orange juice, and lettuce. T-P-S: Do you think those foods are good for your body? Would those be healthy foods for Gregory to eat if he were a person?**

T-P-S: What else do you see in the illustration? Why did the illustrators Jose Aruego and Ariane Dewey draw the flashlight (clock, key, hair dryer, rolling pin, and any other items that students identify) in the picture? Do you think goats and people eat the same kinds of foods? Why (or why not)? Explain that many people think that goats eat all sorts of things that are not food such as old tires, tins cans, and cardboard boxes.

Mitchell Sharmat wrote a very silly story about Gregory the goat and what he likes to eat. T-P-S: What do you think the story will be about from the clues in this illustration?

- Introduce the story vocabulary words.

We will hear some new words in our story. Display the book cover. **One of those words is in the title of the story. The word is “terrible.” In this story, “terrible” means bad.** Read the title, substituting the word “bad” for “terrible.” **What does it mean if you say someone is a bad eater?**

Another word is “revolting.” When we say something is “revolting,” it means it is disgusting or awful. T-P-S: **Tell your partner something that you think is revolting.**

In the story, Gregory’s doctor says picky eaters develop a taste for good food. When we develop a taste for something, it means we learn to like it.



Purpose for reading

Introduce the good-reader skill for today.

Good readers have a purpose for reading. They know why they want to read something. Maybe it’s to learn something, or maybe it’s just to relax and have fun. Why do you think we are going to read this book today?

During Reading



- Use Think-Pair-Share or Whole-Group Response to engage students in an ongoing discussion about the story as guided by the questions and comments below.
 - **Page 5:** T-P-S: **Why do Mother and Father Goat want Gregory to eat a tin can, a box, a rug, and a bottle cap?**
 - **Page 7:** WGR: **Does Gregory like to eat the same things that his mother and father like to eat? No.** T-P-S: **What foods do you like to eat that are the same kinds of things your mother, father, aunt, or grandfather like to eat?**
 - **I heard our new word “revolting” in this part of the story. Father Goat thinks that the food Gregory chooses is revolting. That means he thinks it is disgusting. Father and Mother Goat think that Gregory is making bad food choices.** T-P-S: **What do you think about Gregory’s food choices?**
 - **Page 16:** T-P-S: **Why does Mother Goat give Gregory spaghetti and a shoelace in tomato sauce? Dr. Ram told Mother Goat that picky eaters have to develop a taste for good food slowly. “Develop” is a new word that means to learn to like something. So Mother Goat gives Gregory a food to try that goats eat so he can develop a taste for things such as shoelaces.**
 - **Page 19:** T-P-S: **Why are Mother Goat and Father Goat’s things missing? What do you think Mother Goat and Father Goat will do so Gregory doesn’t eat their things?**
 - **Page 23:** T-P-S: **Why does Gregory have a stomachache? What other character did we read about who had a stomachache after he ate too much food? *The hungry caterpillar*.**

After Reading

Gregory's mother thinks bananas, orange juice, and fish are bad food choices. T-P-S: How would your family feel if you chose these foods?

- Make summative statements about the story that reinforce the STaR vocabulary. Guide students to make sentences with the words.

In the beginning of the story, Gregory's parents think he makes really bad choices about the foods he eats. That makes me think of our new word "terrible." Let's make a sentence together using the word "terrible." T-P-S: Talk to your partner about ideas that you have for our sentence.

- Use students' ideas to develop a sentence. Write the sentence on the board in front of students, saying each word as you write it. Repeat with the words "revolting" and "develop."



Use the 1-2-3 Move signal to move students from the STaR area to the dramatic play lab for the beginning of the lab tour.



Learning Labs

TIMING GOAL: 40 minutes

Routine

1. Have a lab tour to explain the activities or materials in any new labs.
2. Guide students as they select the lab that they will visit. Use the lab-management system to ensure that not too many students plan to visit the same lab at the same time.
3. Students will complete their Learning Lab plan. Conference with as many students as possible about their writing before they are dismissed to labs.
 - Write the code for the writing stage exhibited by the student in the top right-hand corner of the student's paper.
 - Use the methods described in the *Writing Development Feedback Guide* to provide feedback.
4. Monitor students as they visit their selected labs.

Dramatic Play Lab | KinderCorner Cafe

Description:

- The dramatic play lab will be a cafe.

Purpose:

- Participation in this lab will reinforce thematic concepts and help students to develop cognitive skills through role play and the creative use of props. It will also help to develop oral language.

When You Tour:



- Explain that today the dramatic play lab will be a cafe.
- Use Think-Pair-Share to have students identify the different roles that they could play in a cafe. *Customer, cashier, waiter/waitress, cook, owner, delivery person, etc.*
- Remind students to specify which role they would like to play as they write their lab plans.
- Point out the different props and materials that they will find in the area. Use Think-Pair-Share to have students discuss what kinds of props they can create for the cafe. *Signs, menus, cash register, counter, stove, plates, utensils, glasses, etc.*

Facilitate Learning:

- Ask questions that will help students to develop mature levels of play by prompting them to think about their roles, the props, and the rules they created for the scenario. For best results, jump in, and join the play as you interact with students.

Examples:

- (As a customer) **I'm trying to eat healthy foods. I wonder what dish I can order that will be good for me.**
- (As a cook) **Did I put too much salt in the soup? How can I make this lasagna taste better?**



When students seem to need help developing their play, acknowledge that some students may not know the restaurant experience, and participate in the situations they have begun to create. In this way, you can provide scaffolding that extends and enriches their play and that, at the same time, teaches literacy skills. You might say, "Welcome to the KinderCorner Cafe. The special today is spaghetti and meatballs. Would you like to order some?" Then model writing the order on a note pad. You might take on the role of the cook and use the Think Aloud strategy to explain your role. Put on the chef's hat, and look at a recipe while saying, "Hmmm. I wonder what I should cook today? Ah, yes. My customers would probably like this special chicken recipe. I think I will prepare some for dinner." Be ready to step aside and allow students to continue on their own.

Blocks Lab | Build It!

Description:

- Students will build things with blocks.

Purpose:

- Participation in this lab will help students to develop motor skills, hand-eye coordination, spatial skills, creative problem-solving skills, social skills, and language skills.

When You Tour:

- Point out that the blocks lab is open today.

Facilitate Learning:

- Ask questions, or make comments, that will encourage students to expand or move into imaginary scenarios. For best results, jump in, and join the play as you interact with students.

Example:

- **I'm going to build a restaurant. I wonder what I could use for tables.**

Art Lab | Creation Station

Description:

- Students will use open-ended materials to freely create.

Purpose:

- Reinforce thematic concepts. Provide the opportunity for students to make choices about what they would like to make and about the materials they would like to use to stimulate creativity.

When You Tour:

- Point out any new materials that you have added to the lab.

Facilitate Learning:

- When interacting with students about their creations, try to focus on the techniques or materials that they have used as opposed to the products.

Examples:

- **Tell me about why you used crayons instead of markers.**
- **How did you _____?**

Classroom Library Lab | What's Cooking?

Description:

- Students will have the opportunity to explore cookbooks independently or with a friend.

Purpose:

- This lab provides practice with correct book handling and the opportunity to explore letters, words, and sentences in the context of a cookbook. For some students, this lab provides practice with reading.

When You Tour:

- Point out the cookbooks and recipes that you have placed in the lab. Ask, **What kinds of books are these?**
- Explain that a cookbook is a book that has recipes and cooking directions. A recipe tells how much of each kind of food is needed to make something with several ingredients such as cakes, soups, and casseroles.
- Tell students that they may use the cookbooks and recipes to get ideas for things to cook in the cafe.

Facilitate Learning:

- Talk with students about what they see in these books. Do they notice the format? Are there pictures of the finished products? Do they notice the numbers on the pages?
- Ask questions such as “Which picture looks like something you would like to eat?” and “What ingredients do you think you would need to make this food?”
- Reinforce theme-related vocabulary by using the words in questions and statements as you converse with students.

Examples:

- **This recipe would help us make a really healthy meal! When we eat healthy foods like these, we have a lot of energy.**

Literacy Lab | Play School**Description:**

- Students will use materials commonly found in classrooms to play school.

Purpose:

- This lab provides students with an opportunity to develop cognitive skills through role play and the creative use of props. It will also help to develop oral language and literacy skills.

When You Tour:

- Encourage students to play school. Have students name the different roles that can be played. Point out the materials that are available, and remind students that they can also make things they need with items from the Wonder Box.

Facilitate Learning:

- Use this opportunity to provide guidance or coaching to students who have not demonstrated mastery of objectives as indicated on the weekly record form. Engage students in conversation to expand their vocabularies, and encourage them to speak in complete sentences. Any guidance or instruction should be in the context of joining, not interrupting, the play.

Examples:

- (To the student playing the teacher) **I want to read this story, but I don't know what page comes next. Can you help me?**

Math Lab | Bigger or Smaller?

Description:

- Students will sort and order objects by size.

Purpose:

- This lab provides students with an opportunity to compare the size of objects and order them from biggest to smallest.

When You Tour:

- Remind students that they are sorting objects by size. Explain that today they will pretend that they are working in an art-supply store. They are in charge of organizing the art supplies, from biggest to smallest, on the store shelves.

Facilitate Learning:

- Ask students to explain how they organized and ordered the objects in the math lab. Encourage them to pretend that the various objects are art supplies, using items from the Wonder Box as needed. Jump in, and join the play as you interact with students.

Examples:

- **Excuse me. I need a paintbrush that is bigger than this paintbrush. Which one should I choose?**
- **Hi, I'm a new worker here at this art-supply store. I need to put these drawing pencils on the shelf, in order, from biggest to smallest. Can you help me?**
- **What strategy did you use to write _____?**
- **I like how you are writing about art today since it is the theme for this unit.**

Computer/Media Lab | Free Exploration

Description:

- Students will explore educational software or listen to music with computers, CD players, or other digital devices.

Purpose:

- This lab provides students with an opportunity to explore technology, reinforce literacy concepts in a new context, or enjoy music.

When You Tour:

- Remind students that they can use educational software or listen to music with computers, CD players, or other digital devices.

Facilitate Learning:

- Take time this week to spend some time with students in this lab, and engage in discussion about the music they are listening to or the software they are using.

Sand/Water Lab | Free Exploration

Description:

- Students will explore the properties of sand and/or water by experimenting with a variety of tools.

Purpose:

- This lab provides students with an opportunity to investigate the natural world with a focus on water and sand.

When You Tour:

- Remind students of any new tools or materials that you have placed in the lab.

Facilitate Learning:

- Ask questions that will reinforce thematic concepts or that will help students to think about the nature of sand and water and the tools and materials in the lab. For best results, jump in, and join the play as you interact with students.

Examples:

- **Can you make a giant sand pie? Is pie a healthy food or something we should only eat occasionally?**

Science Lab | Scientist's Station: Fruit Examination

Description:

- Students will use materials and tools to investigate the outside of fruits.

Purpose:

- This lab provides students with opportunities to observe, investigate, and record.

When You Tour:

- Point out the fruits and exploratory tools that you have placed in the lab. You might cut the fruits in half as part of the lab tour. Explain that students can examine and compare the fruits.
- Refer to the Science Steps poster as you ask students what kinds of things they might want to find out about the fruits (how the different fruits are similar and different, how much each fruit weighs, what differences there are in the textures of the skins or scents of the fruits, etc.).

Facilitate Learning:

- Use the prompts and questions to reinforce scientific concepts and to facilitate oral-language development.

Examples:

- **What are you wondering about the fruit?**
- **Tell me about what you have discovered.**

Teacher's Note: You may want to refrigerate the food from the lab for use on day 3, when students will examine the seeds inside each fruit.

Writing Lab | Menu Makers

Description:

- Students will write the names, draw pictures, or glue pictures of food items from magazines to create menus for the KinderCorner Cafe.

Purpose:

- This lab provides students with an opportunity to practice writing that is related to the theme.

When You Tour:

- Tell students they can make menus.
- Point out the materials that you have placed in the lab for writing menus. Explain that students can write the names, draw pictures, or glue pictures of food items from magazines to create menus for the KinderCorner Cafe.
- Explain that a menu tells the customers what food choices they have. Show several sample menus from local restaurants.
- Refer to the Today's Special sign. Explain that many restaurants offer one or two items for a reduced price each day. Tell students that they may write the name of a food on the board.
- Encourage students to brainstorm and decide what foods will be on the menu.

Facilitate Learning:

- Ask students to read their writing to you. Prompt students, and give specific feedback about the content of what they have written. Acknowledge any emergent-writing strategies that they have used.

Examples:

- **What kinds of foods do you want to serve at the KinderCorner Cafe?**
- **I see you used a lot of the letters that we have been learning! I see an _____ right here and an _____ to stand for _____.**



Provide five-minute and three-minute warnings before the end of the labs. Then sing the clean-up song to prompt students to put away the lab items and move to the 15-Minute Math board.



15-Minute Math

TIMING GOAL: 15 minutes

Calendar



- Invite students to say the months of the year with you. Then say, **Let's practice counting. Help me count the months of the year.** Touch, and count, **1, 2, 3, 4, 5, 6, 7, 8, 9, 10, 11, 12.** **How many months are in a year?** *Twelve.* **Do you remember what month it is now?** *Answers may vary.*
- Point to the days of the week on the calendar, and ask, **If you know how many days are in a week, say it out loud!** WGR: *Seven.* **Let's practice counting again.** Touch, and count, **1, 2, 3, 4, 5, 6, 7.** **There are seven days in a week.**
- Point to the days of the week on the calendar, and say, **Say the days of the week with me—Sunday, Monday, Tuesday, Wednesday, Thursday, Friday, Saturday.** **What day is today?** *Replies.* **Today is** (day of the week).

Days of the Week

- Point to the Days of the Week pockets. Turn the card to reveal today's date. Place the Today card in the pocket holder behind the appropriate date card, and say, **Today is** (day of the week), **the** (date) **of** (month). Place the Yesterday card in the pocket holder behind the appropriate date, and say, **Yesterday was** (day of the week). **If yesterday was** (day of the week) **and today is** (day of the week), **then tomorrow must be** (day of the week). Place the Tomorrow card in the pocket behind the appropriate date card. Do not turn the card to reveal the date. Model a Think Aloud by saying, **I wonder what the date will be tomorrow?**

Days of School Tape

- Point to the Days of School Tape, and ask, **What number do I need to write on the tape?** (*Current number of days*). **Why?** *Because we've been in school ___ days.* Use a marker to record the number on the tape. Point to the numbers on the tape, and invite students to read them with you. Then say, **We have been in school ___ days.**

Hundreds Chart

- Ask students to determine which number you will color today. After you color it, invite them to read the numbers in the colored boxes with you. Point out that when you colored in today's number, you completed ___ rows plus ___ squares on the Hundreds Chart.

Ten-Frames

- Add a dot to the ten-frame, and say how many dots there should be. Invite students to count aloud with you the number of dots as you point to each one. When you finish counting, say, **Today is the** (date), **and we have** (same number as the date) **dots on our ten-frames.**

Teacher's Note: If today is Monday, add two dots to the ten-frames for Saturday and Sunday before students arrive.



Recite a favorite Rhyme Time chant as students move to the area where you will serve the snack.

Snack • Outside • Gross-Motor Play

TIMING GOAL: 30 minutes

Snack

- Serve fruit, vegetables, or one of the other foods that Gregory likes. Talk with students about the foods that Gregory likes and how good those foods are for growing children.
- Invite students to talk with their partners about the Partner Challenge. **Our Partner Challenge today is to tell your partner what you do when you get angry.** Use Think-Pair-Share to review active-listening skills. Encourage students to use Say-It-Back and/or to ask questions to help them better understand what their partners say.



Distribute pocket points when you observe students using active-listening skills with their partners.

Outside/Gross-Motor Play

- Those students who would like structured play may play a game of Bread, Bread, Fruit, a variation of Duck, Duck, Goose. Encourage students who engage in this structured play to use some of the outside time to engage in unstructured play.



When students come back inside, select one student to play teacher. As students return to the gathering area for Stepping Stones, that student will point to each word on the word wall for the other students to read.



Stepping Stones

TIMING GOAL: 30 minutes

Beginning Phonics

- Point to each mnemonic picture on the wall frieze, and ask students to name each picture.
- Show the Animated Alphabet segments for /e/, /l/, and /h/.



Emergent Reading

Story Introduction

- Show the cover of *Healthy Foods*. Introduce the title and author.

We are talking about the importance of eating healthy food today, and that's what this book is all about. We know that healthy foods help us grow and give us energy.

The pictures in this book will help us know what the words on each page say. We can also use the letter sound at the beginning of each word to help us.

Point to the word "I" on the word wall. **We will also see this word in our story on every page. What does this word say? I. Let's review all of our words.** Quickly point to each word on the word wall, and have students read them in unison.

If students notice or ask about the "ea" in the words "healthy" and "eat," say, in a matter of fact way, that when "e" and "a" stand next to each other, they make a new sound. Sometimes when they stand together, they say /e/, like in the word "healthy," and sometimes they say /ee/, like in the word "eat."

- Read the story to students. Facilitate a brief discussion about the food item on each page. Ask students whether they've tasted the food and, if so, whether they like it. You may also have them identify the food group that the food belongs in (vegetables, fruits, grain, dairy, protein, or fats and sugars). Students will learn more about each of these food groups in this unit.
 - **Page 1:** Point out the "c" at the beginning of "carrots." Make reference to the curly caterpillar. Carrots belong to the vegetable group.
 - **Page 2:** Point out the "a" at the beginning of the word "apples." Apples belong to the fruit group.
 - **Page 3:** Point out the "b" at the beginning of the word "bread." Bread belongs to the grains group.
 - **Page 4:** Point out the "t" at the beginning of the word "turkey." Like all meats, turkey belongs to the protein group.
 - **Page 5:** Point out the "g" and "b" in "green beans." Green beans belong to the vegetable group.
 - **Page 6:** Point out the "b" at the beginning of the word "bananas." Bananas belong to the fruit group.
 - **Page 7:** Point out that in the word "cereal," the "c" does NOT make the /c/ sound. Sometimes "c" says /s/. Cereal belongs to the grains group.

Guided Group Reading

- Distribute a book to each student. Read the book again, this time inviting students to read in unison with you as they follow along in their own books.

Skill Reinforcement

- Give each partnership a food-word card. Provide a few minutes for partners to match the word on their card to the word in the book.
- Show each page of the book again, in sequential order, from the teacher copy or the interactive whiteboard. As you read each page, invite all partnerships that have the corresponding word card for that page to stand and read the page in unison.



Invite students to sing “March to Math” to signal that it is time for Math Mysteries.

Math Mysteries

TIMING GOAL: 25 minutes

Show What You Know



- Hold up one of the pattern strips on which students recorded their linking-cube patterns, and invite students to name the pattern and what would come next in the pattern. Repeat this with several strips, assessing several students on their pattern-naming and pattern-extending skills.
- Award pocket points if several students are able to successfully name and extend the patterns.

tps

rwe

T-P-S: Think about what you learned during the last math time. What do you know about patterns?

RWE: We know that patterns repeat. We can record patterns. We recorded the patterns that we made with linking cubes by coloring a picture to look like the cubes.

Active Instruction

tps

- Hold up KinderRoo and Joey. Ask students to compare them.

T-P-S: KinderRoo and Joey are going to help us today. I want you to look closely at KinderRoo and Joey. How are they the same? *They are both stuffed animals. They are both kangaroos. They are both brown.*

HX

- Ask students to contrast KinderRoo and Joey. Use the sharing sticks to select students to share their answers.

T-P-S: Now look at KinderRoo and Joey again. How are they different? *KinderRoo has a pouch. Joey is smaller than KinderRoo. KinderRoo is bigger than Joey.*

- Point out that most students noticed that KinderRoo and Joey are not the same size. Explain to students that there are a lot of things that are smaller than KinderRoo, and there are a lot of things that are bigger than KinderRoo.

 This week students will learn how to compare and order objects, and they will have an opportunity to measure objects using nonstandard units of measurement. The measurement activities will also reinforce number-sense concepts as students use one-to-one correspondence as they count to compare.

- Place the box or bag of objects where your students can see it. Explain to students that they will look at the objects and decide whether they are bigger or smaller than KinderRoo. Place a large paper sorting mat on the floor. Write the words “bigger than” above one circle and “smaller than” above the other circle. Explain how to use the sorting mat.
- **Everything in the box that is smaller than KinderRoo will go inside this circle.** Point to the circle labeled “smaller than.” **Everything that is bigger than KinderRoo will go in this circle.** Point to the circle labeled “bigger than.”



- Select a student to come up, take an object out of the box, and hold it up next to KinderRoo for the rest of the class to see.

WGR: **Is this object smaller than or bigger than KinderRoo?**

- Ask the class to point to the circle in which the object should be placed. Have the student place the object in the correct circle on the sorting mat. Continue in the same manner until all the objects have been sorted.
- Review what has been sorted before moving into Partner Practice.



T-P-S: **What can you tell me about this circle?** Point to the circle labeled “bigger than.” *All the objects in that circle are bigger than KinderRoo.* **What can you tell me about this circle?** Point to the circle labeled “smaller than.” *All the objects in that circle are smaller than KinderRoo.*

Partner Practice

- Show the Sort-by-Size Workmat. Explain the activity.

At your tables, you will find a bag with objects in it like the ones we just sorted. You will sort the objects on your mat. On one side of the paintbrush, place all the things that are smaller than the paintbrush. On the other side, you will place all the things that are bigger than the paintbrush. You and your partner will decide together which side of the mat each object belongs on.

- Give each partnership a bag of objects and a sorting mat. Provide time for partners to discuss and sort the objects.

Recap



- Use the sharing sticks to select a few students to share how they sorted their items. Prompt each student to tell which side of the sorting mat the student and his or her partner placed each item on and why. Award pocket points if several students are able to successfully explain how and why they sorted their items.



- Use Think-Pair-Share to review today's lesson with students. **Find one thing in the room that is smaller than KinderRoo. Find something in the room that is bigger than KinderRoo. Do you think that artists think about how big or small things are when they create art?**



- Play "The Smallest Car" video to reinforce the concept of sorting by size.
- Tell students that they will have a chance to sort objects by size in the math lab tomorrow.



Sing "It's time to go to sleep. It's time to count our sheep." Then count in a quiet voice, touch each student lightly on the head, and send them to retrieve their nap-time supplies.

Let's Daydream

TIMING GOAL: 25 minutes

Routine

1. Have students get out their supplies (towels, cots, etc.) for nap time.
2. Read the selected poetry, and play soft music (optional) as students rest.
3. Allow students to quietly look at another book during this time if they prefer.

Recommended Poetry Selection

- "A Circle of Sun," *The 20th Century Children's Poetry Treasury*, page 4

Introduce the Poem

Our poem today is about a circle. It is called "A Circle of Sun." It is a fun, short poem, so I will read it twice.



Gather students in a place where you will model during Write Away.



Write Away

TIMING GOAL: 20 minutes

Prewriting

- Present the writing topic for the day, and encourage students to share their ideas. To discourage copying later, do not write the ideas on the board.

Today we have been talking about how bodies need food for energy and to stay healthy. You are going to write about your favorite food.



What is your favorite food? How does it taste?

- Share an example that applies to you.

I think that I will write a sentence that says, “Tacos with ground beef taste good.”

- Review previously introduced emergent-writing strategies.

T-P-S: What are some things that I can do if I don't know how to write some of the words in my sentence? *Draw a picture, draw a line, write sounds that I know, copy a word, and remember a word.*

I will use these things to write my sentence. You can use them when you write your sentence too.

- Use the previously introduced writing strategies to model writing your sentence.

First, count the words on your fingers as you say the sentence again. Then, draw lines on the board to represent each word.

Example:

I am ready to write my sentence. My sentence is, “Tacos with ground beef taste good.”

- **The first word is “tacos.” I'm going to draw a picture for “tacos.”** Draw a picture of tacos on the first line.
- **The next word is “with.” I remember how to write “with.”** Write “with.”
- **“Ground.” What sounds that we have learned do you hear in “ground”?** Say the word, slowly emphasizing the individual sounds. Write any letters that students say.
- **“Tacos with ground beef taste good.” “Beef” is the next word. I hear the /b/ and /f/ sounds in “beef.”** Write “b” and “f” as you say the sounds.
- **“Taste.” What sound do you hear at the beginning of “taste”? What other sounds do you hear in the word?** Write any sounds that students say.
- **The last word is “good.” I hear the /g/ and /d/ sounds in “good.”** Write “g” and “d” on the last line.
- Reread your sentence, touching each word, or word representation, as you do.

Partner Planning

- Ask students to share what they would like to write with their partners. Encourage them to use the Say-It-Back strategy to show their partners that they are listening.
- Monitor students, and listen to their discussions. Ask one or two students what their partners are planning to write.

Writing

- Distribute pencils and either writing journals or paper.
- Monitor students as they write. Encourage them to use the writing strategies that you have introduced as needed.
- Hold a writing conference with a few students as time permits. Record the stage of writing that you observe for some students on the weekly record form.

Sharing

- Ask students to share their sentences with their partners.
- Use the sharing sticks to select one or two students to share their writing with the class. Acknowledge and celebrate any emergent-writing strategies that they have used.



Invite students to recite or sing “Let’s Think About It” as they move to the gathering area.

Let's Think About It

TIMING GOAL: 20 minutes

Theme-Learning Recap



- Have students sit in a circle.
- Hold up *Gregory, the Terrible Eater*. Review the learning focus of the day.

T-P-S: Why are Gregory’s parents so concerned about what he is eating? They feel that he isn’t making healthy choices. RWE: Gregory’s parents do not think Gregory is eating a very healthy diet. They want him to make healthier choices. KinderRoo also told us that it is important to her that she and Joey eat foods that are good for them so they can grow strong and healthy.

You are going to learn a lot this week about the different kinds of foods you eat and how to make good choices so you will continue to be healthy and strong as you grow up.

- Space the Nutrition Lotto cards in the circle so all students can see them.

I'd like everyone to take turns reaching into KinderRoo's grocery bag and selecting one piece of food. After everyone is holding a food item, you will take turns naming the item and finding its match on one of these food cards.

- Quickly move around the circle, having each student select a food item from the grocery bag.
- Have each student name the item in a complete sentence (e.g., "I choose/have a carton of milk."). Have students match and place their pieces on the appropriate spaces on the Nutrition Lotto boards until everyone has had a turn. Hold up any remaining food items, inviting the entire class to name each item. Place the remaining items on the boards.
- When all the pieces have been placed on the boards, count along with students the number of food items on each board, and say the name of the food group that they belong to.

You will learn about the different food groups this week and next week. You will learn about the different kinds of foods you eat and how to make good choices so your bodies grow strong and healthy!



Vocabulary Review

- Briefly review the new theme-related vocabulary words. Use My Turn, Your Turn to have students practice saying each word. Then provide a brief definition, and make connections to the contexts in which the word was used today.

One of our new words today is "healthy." Foods that are healthy are good for you. T-P-S: When did we see, hear, or use the word "healthy" today?

Another word we learned is "energy." Our bodies get energy from the healthy foods we eat. T-P-S: When did we see, hear, or use the word "energy" today?



- Ask partners to work together to think of a sentence that uses one of the words. Use the sharing sticks to select a student to share the sentence with the class. Use the Oral-Language Scoring Rubric to score the response. Record the score on the weekly record form.

| Oral-Language Scoring Rubric | |
|------------------------------|---------------------------------------------------------------------------------------|
| 70 | The student does not respond, or the response does not make sense. |
| 80 | The student responds with a word or phrase that makes sense. |
| 90 | The student responds in a complete sentence that makes sense. |
| 100 | The student responds in a complete sentence(s) that makes sense and includes details. |

- Use the suggestions below to help foster oral-language development.

Theme Vocabulary:
healthy
energy

| Fostering Richer Language | | |
|-----------------------------------------------------------------------------------------------------|------------------------------------------------------------------------------------------------------------------------------------------|-------------------------------------------------------------------------------------------------------------------------------------------------------------|
| Student Response | Teacher Prompt | Further Prompting |
| The student responds in an incomplete sentence. Healthy food. | Good answer. Can you say that in a complete sentence? | If the student is unable to respond in a sentence, model a sentence for him or her. <i>We can say, I eat healthy food.</i> |
| The student responds in a complete, but not very elaborate, sentence. I eat healthy food. | You made a complete sentence with the word. Can you add some details to your sentence? OR Can you tell us a little more about the _____? | If the student is unable to add details, prompt with a question about the sentence. Can you tell us more about the kinds of healthy food you eat? |



- Award pocket points if the student is able to create a complete sentence.

Partner Challenge

- Review the Partner Challenge of the day.

We have one more opportunity to earn pocket points today! Let's review our Partner Challenge. Our Partner Challenge today is to tell your partner what you do when you get angry. Allow students time to review what they talked about with their partners earlier in the day. If you feel your students are ready to do so, invite them to report what their partners said, demonstrating how active-listening skills help them with the Partner Challenge.



- Award pocket points when you observe students using active-listening skills.
- Invite students to compliment the Cool Kid for successfully demonstrating Getting Along Together skills.

Pocket Points for the Day

- Empty the chips from KinderRoo's pouch, and encourage students to join you in counting them.
- Pour the chips into the jar, and observe how close the total is to the reward line.
- Remind students about their reward.



Home Link/Departure

- Invite students to tell their partners one thing that they did or learned today at school.
- Make any announcements or give reminders (upcoming field trips, picture day, etc.).
- Distribute a theme-introduction letter to each student. Tell students they will find today's Home Link show online when they click on the parrot.
- **Read & Respond: Share one of your KinderCorner books, such as *Trees* or *In My Garden*, with someone in your family. Ask him or her to sign your Read & Respond bookmark.**
- Use the parrot stamp to place an animal image on each student's hand to serve as a reminder to watch today's Home Link show.

Day 2 | Ready, Set...

Focus

Grains are needed for nutrition.

| Additional Materials Needed Today | |
|--------------------------------------------|---------------------------------------------------------------------------------------------------------------------------------------------------------------------------------------------------------------------------------------------------------------------------------------------------------------------------------------------------------------------------------------------------------------------------------------------------|
| Greetings, Readings, & Writings | <ul style="list-style-type: none"> Classroom Library Lab: Copies of the concepts-of-print book <i>Healthy Foods</i> and the trade book <i>Gregory, the Terrible Eater</i>, ear and mouth cards Literacy Lab: Concepts-of-print book: <i>Healthy Foods</i>, one set of <i>Healthy Foods</i> word cards (from unit 5) Math Lab: Sort-by-size workmats and classroom objects from yesterday's Math Mysteries lesson |
| Gathering Circle | <ul style="list-style-type: none"> Paper lunch sacks (one per student) Chilly the Penguin Puppet page (appendix) Scissors Glue Tape (optional) Teacher's premade Chilly the Penguin paper-bag puppet Stop and Stay Cool Steps poster or IWB access KinderCorner 2nd Edition Plus Media and Software flash drive |
| Theme Exploration | <ul style="list-style-type: none"> Nutrition Lotto game pieces representing foods from the grains group placed in a grocery bag USDA MyPlate poster Grains from the science lab separated into cups (see materials for science lab) KinderRoo puppet Theme vocabulary word cards for "nutrition" and "ingredients" or IWB access |
| Rhyme Time | <ul style="list-style-type: none"> KinderCorner 2nd Edition Plus Media and Software flash drive |
| STaR | <ul style="list-style-type: none"> Trade book: <i>Gregory, the Terrible Eater</i> <i>Gregory, the Terrible Eater</i> stick puppets (appendix) |
| 15-Minute Math | <ul style="list-style-type: none"> Dry-erase marker |
| Snack/Outside/ Gross-Motor Play | <ul style="list-style-type: none"> Muffins, crackers, bagels, or other snacks made from grains (Be sure to check for wheat or gluten allergies.) Two or three spaghetti noodles, both cooked and uncooked, for demonstration purposes (optional) |

| Additional Materials Needed Today | |
|-----------------------------------|-----------------------------------------------------------------------------------------------------------------------------------------------------------------------------------------------------------------------------------------------------------------------------------------------------------------------------------------------------------------------------------------------------------------------------------------------------------------------------------------------------------------------------------------------------------------------------------------------------------------------------------------------------------------|
| Stepping Stones | <ul style="list-style-type: none"> • Key card for “ch” or IWB access • Letter-Blending Cards (“ch,” “a,” “t,” “w,” “i,” “n”) or IWB access • KinderRoo puppet • /ch/ picture cards (chain, chair, cherry) or IWB access • Common /ch/ objects (optional) • Stepping Stones Partner Practice Booklets for unit 6 • Individual writing boards and writing implements (or pencils if writing in the Partner Practice Booklets) • KinderCorner 2nd Edition Plus Media and Software flash drive • Concepts-of-print book (teacher and student copies): <i>Healthy Foods</i> |
| Math Mysteries | <ul style="list-style-type: none"> • Tissue box • Three pencils (one long blue pencil, one medium-sized red pencil, and one shorter green pencil) • Box (Place the pencils in the box.) • Small plastic bags, each filled with three crayons, pencils, paintbrushes, or markers of different lengths (one bag per partnership) • Joey puppet |
| Let's Daydream | <ul style="list-style-type: none"> • “The Toaster,” <i>The 20th Century Children's Poetry Treasury</i>, page 62 |
| Write Away | <ul style="list-style-type: none"> • No new materials |
| Let's Think About It | <ul style="list-style-type: none"> • Trade book: <i>More Spaghetti, I Say!</i> • Alex puppet • Home Link animal hand stamp: monkey |

Learning Labs—Additional Materials

| |
|-----------------------------------------------------------------------------------------------------------------------------------------------------------------------------------------------------------------------------------------------------|
| Blocks Lab Food Delivery |
| <ul style="list-style-type: none"> • Empty food containers—cereal boxes, egg cartons (washed polystyrene foam only), plastic milk bottles • Toy trucks large enough to transport blocks • Paper • Pencils |
| Math Lab Bigger or Smaller? |
| <ul style="list-style-type: none"> • Variety of objects of different sizes • Sort-by-Size Workmat (appendix) • Sorting bags from Math Mysteries on day 1 |

Science Lab | Scientist's Station: Grains Galore

- Cups (four to six, clear plastic)
- Grains (brown and white rice, spaghetti, wheat, rye, flour, corn, or any available varieties, separated into each of the clear cups)
- Magnifying glasses
- Paper (one sheet placed next to each cup of grain)
- Writing implements

Writing Lab | Healthy Helpings

- USDA MyPlate page (appendix)
- Glue
- Scissors
- Read and Recycle box (Make sure there are plenty of pictures of food in the materials. Grocery-store circulars are an excellent resource for food pictures.)
- Paper plates (dinner size)

Day 2

Greetings, Readings,
& Writings

TIMING GOAL: 15 minutes

| Student Routines | Teacher Routines |
|-------------------------------------------------------------------------------------------------------------------------------------------------------------------------|----------------------------------------------------------------------------------------------------------------------------------------------------------------------------------------------------------------------------------------------------------------------------------------------------------------------------------------------------------------------------------------------------------------------------------------------------------|
| <ol style="list-style-type: none"> 1. Remove coats and backpacks. 2. Turn in homework. 3. Sign in. 4. Self-select activities. | <ol style="list-style-type: none"> 1. Greet parents and students. 2. Remind students to read the Arrival Activities poster as they prepare for their day. 3. Encourage students to describe what they are doing in full sentences as you observe their activities. 4. Observe for student progress with their individualized objectives from the weekly record form. Circle demonstrated skills if applicable. |

Homework

- Read & Respond

Available Activities

Classroom Library Lab

- Display *Gregory, the Terrible Eater* in a prominent place in the library. Invite students to explore the book. Also place a few copies of *Healthy Foods* in the lab. Encourage students to practice reading the books with a friend.

Literacy Lab

- Add a few copies of *Healthy Foods* and the *Healthy Foods* word cards to the lab. Encourage students to match the text from each card to the text in the book.

Math Lab

- Point out the Sort-by-Size Workmats and classroom objects that you have added to the lab. Encourage students to continue their sorting activity from yesterday's Math Mysteries lesson.

Computer/Media Lab

- Same as day 1

Writing Lab

- Same as day 1

Other

- If you have any theme-related puzzles or games, make them available.

Observe Student Progress

- As you interact with students, ask several of them the following questions to measure their skill development as identified on the weekly record form. Document any demonstration of the skills on the form.

Phonological Awareness: Identifying Initial Sounds

Think about the sounds that you hear at the beginning of these words. What sound do you hear at the beginning of “bike”? /b/. What sound do you hear at the beginning of “fork”? /f/. What sound do you hear at the beginning of “sheep”? /sh/.

- You may repeat the words if necessary. Students must give the correct initial sound for all three words to demonstrate mastery of the skill.

Graphemes

- This week you will check to see whether each student can produce the sounds and write the shapes for the letters “e,” “l,” and “h.” As students work together in their Stepping Stones Partner Practice Booklets, you will have many opportunities to collect this information.

Beginning Reading

- This week find out if your students can sound out the word “leg.” You may observe students as they read the word in their Stepping Stones Partner Practice Booklets on day 5, or ask them to read the word at another time during the week.

Emergent Writing

- When you conference with a student about his or her writing during Learning Labs planning or a Write Away lesson, record the code for the highest stage that he or she exhibits (before coaching) on the weekly record form.
 - **D** – Drawing
 - **S** – Linear Scribble
 - **LL** – Letterlike Shapes
 - **RL** – Random Letters
 - **AS1** – Initial Attempts at Approximated Spelling
 - **AS2** – Early Approximated Spelling
 - **AS3** – Intermediate Approximated Spelling
 - **AS4** – Advanced Approximated Spelling
 - **CS** – Conventional Spelling

Math

- In Math Mysteries this week, students will be learning about shapes. On the weekly record form, you will record whether each student can recognize a circle, a square, a rectangle, and a triangle. Evidence of these skills may be observed during the lesson, or you can ask students questions about each shape individually.

Examples:

- **Can you find something in our classroom that is shaped like a circle?**

- Which of these pattern blocks is shaped like a circle?
- Which of the shapes on this paper is a circle?
- Continue to ask these questions of different students each day during Greetings, Readings, & Writings, Learning Labs, or other available times. Try to collect information about each skill for every student this week.



Sing a transitional gathering song. Encourage students to sing along as they move to the gathering area.

Gathering Circle

TIMING GOAL: 20 minutes

Routine

1. Welcome students to the Gathering Circle.
2. Check attendance.
3. Discuss yesterday's homework assignment. Award pocket points if at least half the students completed their homework.
4. Remind students about the responsibilities associated with each classroom job as needed.
5. Make sure that students are sitting with their partners for the week.
6. Remind students about the responsibilities of the Cool Kid.

Home Link Debrief

- Invite children to share what they remember from last night's Home Link show.
 - T-P-S: **Last night's show talked about healthy foods. What is one food that is a good choice for a healthy snack?**
- Use the sharing sticks to select two or three children to share their responses with the whole class. Award pocket points in recognition of thoughtful answers.



Active Instruction

- Use Chilly the Penguin to introduce the Getting Along Together skill Stop and Stay Cool.



Bring out the Chilly paper-bag puppet, and say, **I'd like to introduce you to a new friend. His name is Chilly. We are going to watch a video that tells a story about Chilly, and let's see if you can figure out how he got his name.**

- Show the "Stop and Stay Cool (excerpt)" video.



T-P-S: **Why is this little penguin's name Chilly?** *He cooled down when he got angry; he is cool and calm; and he can "chill out."*

- Use the video content and the Stop and Stay Cool Steps poster to introduce the Stop and Stay Cool process.

T-P-S: How did Chilly feel when he couldn't catch a fish? How do you know he was very angry? *He was so angry that his face turned red.*

Chilly used a new skill that we haven't talked about before called Stop and Stay Cool. Let's look at this poster of Chilly using Stop and Stay Cool. Discuss each of the steps on the poster.

At the bottom, he says he is cool and ready for school. Wow! Chilly is a smart little penguin. He stopped, gave himself a hug, breathed in and out slowly, and got his angry feelings under control.

Partner Practice

- Invite partners to practice following the Stop and Stay Cool steps.

Now we're going to practice following the steps. Turn to face your partner. Pretend that you are Chilly and that the fish you couldn't catch just laughed at you. Show your partner a very mad face. Some students may groan like Chilly does in the video.

Next, Chilly stops and thinks. Let's practice that. Look at your partner. Is your partner still making an angry face or making angry noises?

Now give yourself a Chilly hug.

Breathe in while I count to 5. Count to 5 in a soothing voice. **Now slowly breathe out.**

Now you are cool and ready for school!

- Post the Stop and Stay Cool Steps poster where all students can use it as a reference. **This poster will help us remember the steps we can take to stop and stay cool when we get upset. Then we can solve our conflicts in a cool and calm way.**

Partner Challenge

- Introduce the challenge.

Now that we know how to stop and stay cool, we can use it before we get so angry that we get into a fight or have a conflict with a friend. Today's Partner Challenge is to think about how the steps in Stop and Stay Cool help you calm down. Give yourself a chilly hug. Now think about how it makes you feel. At snack time, you will talk more with your partner and tell him or her how giving yourself a hug helps you when you feel yourself losing control. Allow a moment for students to give themselves a hug and to think about how they feel.

- Tell students they will earn pocket points when they show this step of Stop and Stay Cool while they talk with their partners.



Theme Exploration

TIMING GOAL: 15 minutes



Partnership Question of the Day

T-P-S: **Did you eat a healthy breakfast this morning?**

This week we are learning about the healthy foods our bodies need to stay well. Our Daily Message will tell us about some foods that are good for our bodies.

Daily Message

Grains are needed for nutrition.



- Write the Daily Message in front of students, reading each word as you finish writing it. Then read the entire message again, touching each word as you read it.
- Reinforce literacy objectives by pointing out the following:
 - Reread the message, emphasizing the initial /n/ sound in the words “needed” and “nutrition.” WGR: **What sound do you hear at the beginning of these words? /n/**
 - Invite students to clap out the syllables in each word. T-P-S: **Which word has the most claps? “Nutrition.” It has three claps.**

Theme Learning



- Explain the content of the Daily Message.

Our Daily Message tells us that grains are needed for nutrition. T-P-S: What do you think the word “nutrition” means? RWE: When we talk about nutrition, we are talking about feeding our bodies with healthy foods and drinks.

Last week we learned that bread is made from grains. Today we will see what other foods are made from grains.

- Show the MyPlate poster. Point out the plate and the glass on the placemat. Point out that the plate is divided into four sections: fruits, vegetables, grains, and proteins. Point out that the glass next to the plate is for dairy.

Each day this week, we will talk about a different type of food and place those foods on this plate. This plate helps you understand what kinds of foods your body needs and how much of each type of food you should eat.
- Place the MyPlate poster on the floor. Bring out KinderRoo next to her grocery bag filled with foods from the grain group. Ask KinderRoo, **May we see what you have in your grocery bag today?**

- Have KinderRoo bring the bag to a student and invite him or her to pull a food from the bag. Have students name the item that is presented. Model the use of the name of the food in a complete sentence. Then allow the student to lay the food item or picture in the grains section of the plate graphic. Continue this process with additional students until all the foods have been presented.

These are just some of the kinds of food that our bodies need. They give us energy and keep us strong and healthy.

All the foods that we just put on the plate have something in common, something that is the same. Each of these foods is made with grains. The grains section of the plate is large because we need to eat a lot of them. When you look at your dinner plate tonight, this much of your plate should be filled with foods made from grains.

- Show the grains that you have prepared for the science lab.

Grains are the seeds or the fruit part of grasses. Grains are mixed together with other ingredients to make pretzels, breads, crackers, cereals, pasta, and other kinds of foods. All these foods use grains as one of their ingredients. Grains are what they have in common.

When you visit the science lab today, you may look closely at the different types of grains with a magnifying glass and feel the grains with your fingers.



- Play the digital dictionary videos for “nutrition” and “ingredients.”
- Re-emphasize the theme-related vocabulary words. Post the words, or point to them on the interactive whiteboard, as you discuss each one.

Our two new words for today are “nutrition” and “ingredients.”

You can practice good nutrition by eating healthy foods and drinking healthy drinks. Eating unhealthy foods can lead to poor nutrition and can cause your body to feel bad. I can make a sentence with the word “nutrition.”

My body needs grains for good nutrition.

Ingredients are all the foods that mix together to form a new food. Grains are one of the ingredients in bread. We know from last week that yeast is another ingredient in some kinds of bread. I can make a sentence with the word “ingredients.”

My favorite sandwich has three ingredients: bread, peanut butter, and jelly!



Ask students to stand up as they sing “It’s Time for a Rhyme” to signal the transition to Rhyme Time.



Rhyme Time

TIMING GOAL: 5 minutes

Say the Rhyme

- Have students recite “A Healthy Treat.” Encourage them to do the physical motions that accompany the rhyme.
- Read the words (see day 1), or play the video.



Develop Phonemic Awareness—Auditory Sound Blending

- Challenge students to say it fast after you say each of the words below in Joey Talk:

| | | | | | |
|----------|-------------|------------|--------------|----------|-------------|
| /m-il-k/ | <i>milk</i> | /b-r-ea-d/ | <i>bread</i> | /m-ea-t/ | <i>meat</i> |
|----------|-------------|------------|--------------|----------|-------------|



- Award pocket points if students are able to successfully blend the sounds to make words.



TRANSITION

- Sing the song “Let’s Read Together” with students.



STaR

Story Retell

TIMING GOAL: 20 minutes

Review



- Review the title, author, and illustrator.

We read this story yesterday. Do you remember the title? Gregory, the Terrible Eater.

WGR: The author is Mitchell Sharmat. What does the author do? *The author thinks of the story, writes the words.*

WGR: The illustrators are Jose Aruego and Ariane Dewey. What does the illustrator do? *The illustrator paints, draws, creates the pictures.*

- Review the story vocabulary words. Show the word on a word card or on the interactive whiteboard as you refer to it. Invite partners to make a sentence with each word.



We learned some new words in our story yesterday. The first word was “terrible.” What does terrible mean? *Bad.*

T-P-S: Can you think of a sentence that uses the word “terrible”? Work with your partner to think of a sentence.



- Use the sharing sticks to select students to share their responses. Award pocket points for successful responses.
- Repeat this process with the word “revolting.” *The word “revolting” means disgusting.*
- Repeat this process with the word “develop.” *The word “develop” means learn to like something (relative to food).*

Story Retell

- Place students in groups of four. Distribute one set of puppets to each group. Invite each student to take one puppet. Name the characters that the puppets represent. Ascertain that each student knows which puppet he or she has so the student knows which character’s part he or she will act out.
- Read the story, stopping on the following pages for students to dramatize their characters’ parts.
 - **Page 1:** Gregory pretends to jump from rock to rock.
 - **Page 4:** Gregory’s parents offer him food; Gregory refuses.
 - **Page 7:** Mother and Father Goat stop eating and give a nasty look at Gregory.
 - **Page 8:** Mother and Father Goat pretend to eat the newspaper.
 - **Page 11:** Mother and Father Goat offer Gregory food; he leaves the table.
 - **Page 12:** The family goes to the doctor. The doctor is eating boxes.
 - **Page 14:** The doctor examines Gregory.
 - **Page 17:** Gregory looks proud of himself.
 - **Page 23:** Gregory looks sick to his stomach.
 - **Page 25:** Mother and Father Goat comfort Gregory. Gregory moans and groans.
 - **Page 28:** The Goat family shares a meal.
- If time and students’ interest permit, have students switch character roles. and read the story again. This will give students who dramatize the doctor’s role for the first reading the opportunity to have a more active part during the second reading.
- Close the activity by asking students to pretend that they are Gregory and tell which of the goat foods they would like to taste. T-P-S: **Tell your partner which of the things Mother and Father Goat want Gregory to try that you would choose if you were Gregory. Why?**



Use the 1-2-3 Move signal to move students from the STaR area to the dramatic play lab for the beginning of the lab tour.



Learning Labs

TIMING GOAL: 40 minutes

Routine

1. Have a lab tour to explain the activities or materials in any new labs.
2. Guide students as they select the lab that they will visit. Use the lab-management system to ensure that not too many students plan to visit the same lab at the same time.
3. Students will complete their Learning Lab plan. Conference with as many students as possible about their writing before they are dismissed to labs.
 - Write the code for the writing stage exhibited by the student in the top right-hand corner of the student's paper.
 - Use the methods described in the *Writing Development Feedback Guide* to provide feedback.
4. Monitor students as they visit their selected labs.

Dramatic Play Lab | KinderCorner Cafe

Description:

- The dramatic play lab will be a cafe.

When You Tour:

- Remind students that the dramatic play area will be a cafe. Ask students what kinds of breads and cereals they can serve in the cafe.

Blocks Lab | Food Delivery

Description:

- Students will use the trucks to transport food to the KinderCorner Cafe.

Purpose:

- Participation in this lab will help students to develop fine-motor skills, cognitive skills through role play, and oral language. It will also provide opportunities to practice estimating, categorizing, and using writing to record information.

When You Tour:

- Suggest that some students use the trucks to transport food to the KinderCorner Cafe.

Facilitate Learning:

- Join students as they play in the blocks lab.

- Ask students questions that prompt them to describe the foods that they are bringing to the cafe and how they plan to get it there.

Examples:

- **How many containers of food do you think we can fit on the truck?**
 - **How many trucks/trips will we need to make?**
 - **What kinds of grain products do we have?**
- Invite the delivery students to talk with students in the cafe to find out what kinds of foods are needed to serve the customers. Perhaps the cafe students could write an order for the driver to fill and deliver. Encourage them to write the number of each item that is being ordered.

Art Lab | Creation Station

Description:

- Students will use open-ended materials to freely create.

When You Tour:

- Remind students that the lab is open today.

Classroom Library Lab | What's Cooking?

Description:

- Students will continue to explore books independently or with a friend. Theme-related books will be added to the regular classroom library.

When You Tour:

- Remind students that they can find cookbooks in the classroom library lab. Encourage students to look for bread recipes.

Literacy Lab | Play School

Description:

- Students will continue to use materials commonly found in classrooms to play school.

When You Tour:

- Remind students that the lab is open today.

Math Lab | Bigger or Smaller?

Description:

- Students will sort objects by size.

Purpose:

- This lab provides students with an opportunity to compare the size of objects and classify them as bigger than or smaller than another object.

When You Tour:

- Point that out the sorting bags and Sort-by-Size Workmats from yesterday's Math Mysteries lesson are now in the math lab. Explain that in the math lab today, students will pretend that they are artists who wants to paint pictures of bigger objects and smaller objects.

Facilitate Learning:

- As students sort the objects, ask them to explain how they determined where to place each object. Encourage them to use the terms "bigger than" and "smaller than" as they explain their thinking.
- Join in the play by telling students that you are an artist who can only paint small objects because you only use small canvases and small paintbrushes. Ask students to show you the objects that might be good for you to paint. Do the same for bigger objects.

Computer/Media Lab | Free Exploration**Description:**

- Students will continue to explore educational software or listen to music with computers, CD players, or other digital devices.

When You Tour:

- Remind students that they can explore educational software or listen to music.

Sand/Water Lab | Free Exploration**Description:**

- Students will continue to explore the properties of sand and/or water by experimenting with a variety of tools.

When You Tour:

- Remind students that the lab is open today.

Facilitate Learning:

- Reinforce theme-related vocabulary by using the words as you converse with students.

Examples:

- **When we prepare foods, we have to measure the ingredients. Can you put one cup of sand/water into this container?**

Science Lab | Scientist's Station: Grains Galore

Description:

- Students will use materials and tools to investigate grains.

Purpose:

- This lab provides students with opportunities to observe, investigate, and record.

When You Tour:

- Point out the cups of grains that you have added to the lab.
- Ask questions to prompt ideas about what students might want to investigate (e.g., how the different grains look or feel different from one another, whether the same amount of different grains weighs the same, etc.)

Facilitate Learning:

- Join students as they examine the grains.
- Ask students questions that prompt them to describe the grains.

Examples:

- **What does this grain look like?**
- **How does this grain feel?**
- **How are these two grains the same?**
- **How are these two grains different?**

Writing Lab | Healthy Helpings

Description:

- Students will cut out and paste the USDA MyPlate graphic and glue it to paper plates. They will then find, cut out, and glue pictures of a variety of foods onto the correct sections of the plate. Students can use the sounds that they know to label each food.

Purpose:

- This lab reinforces thematic concepts and helps to develop fine-motor skills.

When You Tour:

- Explain the steps to students:
 - Cut out and glue the USDA MyPlate graphic to a paper plate.
 - Find pictures of foods from materials in the Read and Recycle box, cut them out, and glue them to the correct sections of the plate.
 - Use sounds that you know to write the name of each food.
- Review any scissor-safety tips or gluing guidelines if necessary.

Facilitate Learning:

- Assist in identifying the correct food groups if necessary.
- Recognize students' efforts to use sounds to spell the names of the foods.
- Reinforce theme-related vocabulary by using the words as you converse with students.

Examples:

- **You have found many nutritious foods! What a healthy meal!**
- **I think the foods you have selected will give you lots of energy!**



Provide five-minute and three-minute warnings before the end of the labs. Then sing the clean-up song to prompt students to put away the lab items and move to the 15-Minute Math board.



15-Minute Math

TIMING GOAL: 15 minutes

Complete the following activities as described on day 1.

Calendar

- Before placing the calendar cutout on the calendar, say, **I wonder what the picture on the calendar cutout will be today. Think about the pattern on the calendar.** Pause to allow time for students to think. **Pair with your partner, and tell your partner what you think the picture will be.** Allow students a minute to share. **Let's share.** Pick several pairs of students to share their ideas and their partners' ideas. Then add the calendar cutout for today's date to the calendar. Ask, **How did you know what today's picture was going to be?** *It is a pattern, and patterns repeat.* Point to the cutout, and say, **Today is** (day of the week), (month and date).

Days of the Week

Days of School Tape

Ten-Frames

Hundreds Chart



Recite a favorite Rhyme Time chant as students move to the area where you will serve the snack.

Snack • Outside • Gross-Motor Play

TIMING GOAL: 30 minutes

Snack

- Serve a snack made from grains. Talk about the source of the grain (wheat, rice, etc.) Because many grain-based foods are round, you may also take this opportunity to reinforce the concept of a circle.
- Invite students to talk about the Partner Challenge. **Our Partner Challenge is to tell your partner how giving yourself a hug helps you when you feel that you are losing control.** Allow students time to discuss the Partner Challenge with their partners.



Award pocket points when students can verbalize how giving themselves a hug can make them feel better.

Outside/Gross-Motor Play

- Those students who would like structured play may play a game of Noodle if you are in an appropriate setting. Have students lie on their backs and relax. They should make their bodies so loose that when you come around and try to lift their arms or legs to shake them, their bodies will wiggle like a cooked spaghetti noodle. After you have demonstrated once, allow students to take turns wiggling one another's arms or legs like noodles.

Teacher's Note: You might bring in some uncooked and cooked spaghetti noodles to show students the difference between the two.



TRANSITION

When students come back inside, select one student to play teacher. As students return to the gathering area for Stepping Stones, that student will point to each word on the word wall for the other students to read.

Stepping Stones

TIMING GOAL: 30 minutes



Beginning Phonics: /ch/ – a bounced sound

Review

- Have students name each mnemonic picture as you point to it on the wall frieze.
- Ask students to provide the sounds for letters that have already been introduced with uppercase and lowercase cards attached.
- Show the Animated Alphabet segment for /w/.



Introduce the New Sound

Silly Sentence

- Present the KinderRoo puppet. Explain that she has a new sound for them to learn—a sound that they will hear in the silly sentence she has brought.
- Say the alliterative phrase two or three times, emphasizing the /ch/ sound at the beginning of each word by softly bouncing it.

The chipmunk chooses cheese.

tps

- Use Think-Pair-Share to ask, **What sound do you hear at the beginning of “chipmunk,” “chooses,” and “cheese”?**
- Explain that /ch/ is a bounced sound. When we say it, we want to be careful to say it softly and quickly, like the motion of a bouncing ball. We have to be careful not to say /chuh/.
- Use My Turn, Your Turn to have students repeat each of the words that begin with /ch/, softly bouncing the /ch/ sound at the beginning of each word.

My Turn
Your Turn

Let's practice that sound.

Teacher: /ch/ ipmunk

Students: /ch/ *ipmunk*

Teacher: /ch/ ooses

Students: /ch/ *ooses*

Teacher: /ch/ eese

Students: /ch/ *eese*

Mnemonic Picture

- Show the picture side of the key card for “ch.” Explain that the picture we have to help us remember the sound /ch/ is a chipmunk that chooses cheese instead of the apple or the cupcake. Point out to students that, like /sh/, the sound they learned last week, /ch/ is made with two letters that they already know standing together. **When /c/ and /h/ stand together, they make a new sound, /ch/.**



Let's watch our funny cartoon about /ch/. It will help us to remember the sound.

- Play the Animated Alphabet segment for /ch/. Point out that the chipmunk makes the /ch/ sound when it chews.

People, Pictures, and Objects

- Have KinderRoo help you identify any students whose names begin with /ch/. Explain that KinderRoo has brought some pictures and objects that begin with /ch/. Say the name of each picture or object as you present it, and emphasize the /ch/ sound.

chain

chair

cherry

- Ask students to name each picture or object as you point to it. Ask, **What sound do you hear at the beginning of _____?** as they name each one.



Making the Sound

- Ask students to think about what is happening in their mouths as they make the /ch/ sound. Have them face their partners and make the sound several times as you ask the following questions:
 - **Is your mouth open or closed when you make the sound?**
 - **What is your tongue doing when you make the sound?**
 - **Gently touch your throat. Can you feel a vibration when you make the sound?**

Partner Practice

Reading Sounds

- Distribute the Partner Practice Booklets and a crayon or pencil to each student. Ask students to open their booklets to the first page. Encourage partners to help each other find the page. Have the partners work together to read the sounds.
 - Jelly will point to the sounds, and Peanut Butter will read them. Jelly will help as needed.
 - After Peanut Butter has finished reading the sounds, Jelly will write their initials in the box at the bottom of Peanut Butter's page.
 - Peanut Butter will point to the sounds, and Jelly will read them. Peanut Butter will help as needed.
 - After Jelly has finished reading, Peanut Butter will write their initials in the box at the bottom of Jelly's page.

Stretch and Read

- Explain that the sounds we have been learning can be put together to make words. Model the process by placing the letter cards for /ch/, /a/, and /t/ a few spaces apart in a pocket chart or along a chalkboard tray. Gradually move the letters closer together, and have students blend the sounds together with you until you say "chat." Repeat with the word "win."

We know that words are made of sounds. We can read a word by saying all the sounds and blending them together. We call this Stretch and Read.

Alphie and his friends can use Stretch and Read to sound out words too. Let's watch.



- Show the Sound and the Furry video segment.

Now you will get to use Stretch and Read to read some words with your partner. The words you will read are different from the words we read together. Let's see who can figure out the words!

- Have students work with their partners, using Stretch and Read, to read the words from their Partner Practice Booklets.
- Use the sharing sticks to select a student to read the sounds for the class. Select another student to read the words. Provide assistance as needed. Award pocket points if they attempt to read all the sounds or words.



Forming the Letter

Introduce the shape of /ch/.

- Explain that the /ch/ sound is made by putting two sounds that we already know how to write together. To write /ch/, first, we write /c/, and then, we write /h/. When those two letters stand together, they say /ch/. Trace the letters with your finger as you say the letter-writing cues.

Remember that to write /c/, we make a shape like the curly caterpillar. We “curl left around the caterpillar.” To write /h/, we think about the horse. We move “from head to toe and over his back.”

Write /ch/.

- Distribute individual whiteboards and dry-erase markers, chalkboards and chalk, or paper and pencils or crayons. You may also use the space provided in the Partner Practice Booklet for writing. Ask students to write /ch/ several times, reciting the cues for /c/ and /h/ with them each time if necessary.
- Ask students to examine their partners' letters for /ch/ and circle the best one. Encourage them to tell their partners why they think it's the best.
- Have students write other letters that they have learned. Encourage them to say the cue as they write each letter.
 - /w/ **Wiggle down, wiggle up, down and up.**
 - /z/ **Zig right, zag left, zig right.**
- Include other review letters as needed by your students.

Stretch and Count/Stretch and Spell

- Call out a word, and ask students to break it down as they count the number of sounds in the word on their fingers. Ask them to draw a line for each sound that is represented in the word. Say the sounds in the word again, and have students write the letters that make the sound on the lines to spell the word.

chat

win

- Collect the Partner Practice Booklets.

Emergent Reading

Story Review

- Briefly review the concepts-of-print book *Healthy Foods*.
 - **Yesterday we read this story about many foods that help our bodies grow and function correctly.**
- Review the focus skills.

Remember that you can use the pictures to help you remember what each page says. You'll also see this word from the word wall. Point to the word “I” on the word wall.

Let's practice that by reading the story together first. Then you will get to read it with your partners. Have the class read the story in unison.

Partner Reading

- Distribute a book to each student.
- Have students read the story with their partners, alternating pages. When they finish, they should switch parts and read the story again.



Invite students to sing “March to Math” to signal that it is time for Math Mysteries.

Math Mysteries

TIMING GOAL: 25 minutes

Show What You Know



- Hold up Joey, and ask students to look at him carefully. Then hold up a tissue box.

T-P-S: Is this tissue box smaller than or bigger than Joey?

RWE: The tissue box is bigger than Joey. I can tell when I place them side by side that the tissue box is bigger.

- Award pocket points if students are able to tell that the tissue box is bigger than Joey.
- Ask students to sit with their partners in a circle so they can see the space in front of you.

T-P-S: Think about what you learned during the last math time. What do you know about sorting by size?

RWE: When we sort by size, we can sort things that are bigger than or smaller than another object—just as we did with our paintbrush sorting mat yesterday.

Active Instruction



- Bring out the box of art materials. Ask students to tell you what is in the box. Explain that these are all things that an artist might use.
- Take the pencils out of the box.

T-P-S: What can you tell me about these pencils? They are all different sizes and colors.

- Ask students to identify the longest pencil.



WGR: Which pencil is longer than the other two? The blue pencil is longer than the other two.

- Place the blue pencil where students can see it. Then hold up the two remaining pencils. Ask students to identify which pencil is longer.

WGR: Which of these two pencils is longer? The red pencil is longer than the green pencil.

- Line up the ends so students can easily see that the blue pencil is longer than the red pencil. Then place the green pencil next to the red pencil in the same manner. Explain to students that you ordered the pencils by size.

Now the pencils are in order by size. The blue pencil is the longest. The red pencil is shorter than the blue pencil, but longer than the green pencil. The green pencil is the shortest.

Partner Practice

- Distribute a small plastic bag with art materials inside to each partnership. Ask students to look at the objects without taking them out of the bags. Tell them to share with their partners what they notice about the three objects in their bags. Then ask students to take the objects out of their bags and put them in order by size.
- Observe to see which partnerships are able to put the objects in order by size. Ask students to tell you how they knew which object was longer than or shorter than the other objects. Assist students who might need a little extra guidance. Note which students can compare objects by increasing size.
- If time allows, you might like to have students return their objects to their bags and switch bags with another partnership to do the activity again.

Recap



- Use the sharing sticks to select a few students to share how they ordered their items. Prompt each student to compare two items and tell which one was shorter and which was longer. Award pocket points if several students are able to successfully explain how and why they sorted their items.
- Review how to decide whether objects are longer or shorter than others.



T-P-S: How did you decide which object was longer than or shorter than the others? *I could tell which object was longer than the others by lining up the ends to see which one was the longest.*



- Play the “Scooter Ordering Objects By Size” video.
- Tell students that they will have a chance to order objects by size in the math lab tomorrow.



Sing “It’s time to go to sleep. It’s time to count our sheep.” Then count in a quiet voice, touch each student lightly on the head, and send them to retrieve their nap-time supplies.



Let's Daydream

TIMING GOAL: 25 minutes

Routine

1. Have students get out their supplies (towels, cots, etc.) for nap time.
2. Read the selected poetry, and play soft music (optional) as students rest.
3. Allow students to quietly look at another book during this time if they prefer.

Recommended Poetry Selection

- “The Toaster,” *The 20th Century Children’s Poetry Treasury*, page 62

Introduce the Poem

Since we’ve been talking about different kinds of foods made with grains today, I thought you might enjoy listening to a poem about toast in a toaster. A toaster is a tool or an appliance that is used when you want to make bread warm and crunchy.

As you listen to the poem, try to picture in your mind the toaster that the author describes. He compares the toaster with a dragon. As you listen to the words, think about why he might compare a toaster and a dragon.



Gather students in a place where you will model during Write Away.



Write Away

TIMING GOAL: 20 minutes

Prewriting

- Present the writing topic for the day, and encourage students to share their ideas. To discourage copying later, do not write the ideas on the board.

Today we learned about breads and cereals. We know that we need breads and cereals for good nutrition. You are going to write about a kind of bread or cereal that you eat for breakfast.



T-P-S: What kind of bread or cereal do you eat for breakfast?

- Share an example that applies to you.

I think that I will write a sentence that says, “I like oatmeal with honey.”

- Review previously introduced emergent-writing strategies.

T-P-S: What are some things that I can do if I don't know how to write some of the words in my sentence? Draw a picture, draw a line, write sounds that I know, copy a word, and remember a word.

I will use these things to write my sentence. You can use them when you write your sentence too.

- Use previously introduced writing strategies to model writing your sentence.

First, count the words on your fingers as you say the sentence again. Then, draw lines on the board to represent each word.

Example:

I am ready to write my sentence. My sentence is, "I like oatmeal with honey."

- **The first word is "I." That word is on the word wall, so I can copy it.**
Write "I" on the first line.
 - **The next word is "like." I hear the /l/ and /k/ sounds in "like."**
Write "l" and "k."
 - **"Oatmeal." What sounds do you hear in "oatmeal"? Say the word slowly, emphasizing the individual sounds. Write any letters that students say.**
 - **"I like oatmeal with honey." "With" is the next word. I remember how to write that word.** Write "with."
 - **The last word is "honey." Do you hear any sounds that you know in "honey"? Say the word slowly, emphasizing the individual sounds. Write any letters that students say on the last line.**
- Reread your sentence, touching each word, or word representation, as you do.

Partner Planning

- Ask students to share what they would like to write with their partners. Encourage them to use the Say-It-Back strategy to show their partners that they are listening.
- Monitor students, and listen to their discussions. Ask one or two students what their partners are planning to write.

Writing

- Distribute pencils and either writing journals or paper.
- Monitor students as they write. Encourage them to use the writing strategies that you have introduced as needed.
- Hold a writing conference with a few students if time permits. On the weekly record form, record the stage of writing that you observe for each of these students.

Sharing



- Ask students to share their sentences with their partners.
- Use the sharing sticks to select one or two students to share their writing with the class. Acknowledge and celebrate any emergent-writing strategies that they have used.



TRANSITION

Invite students to recite or sing “Let’s Think About It” as they move to the gathering area.



Let’s Think About It

TIMING GOAL: 20 minutes

Theme-Learning Recap

- Review the learning focus of the day.

Today we’ve talked about different kinds of foods that have something in common. These foods are all made with grains. Remember that we said grains are the seed or fruit part of grasses. Some of you visited the science lab today and made observations about the grains by looking carefully with a magnifying glass and feeling the grains with your fingers.

- Invite students who visited the writing lab today to bring their plates to the front of the room. Identify any foods made from grains that were found.
- Display the book *More Spaghetti, I Say!*



This is a very funny story about a food that is made with grain. T-P-S: **What is the name of this food in the picture? *Spaghetti*.** Remind students of the sample spaghetti noodles if you shared them to explain the Noodle game during Outside/Gross-Motor Play.

- Read the story to students. If time allows, read the story a second time, encouraging students to join you as you read the rhyming words on each page.
- Present the Alex puppet. Expand thematic concepts by asking Alex the following questions related to the story:

As teacher: **Do monkeys really eat spaghetti?**

As Alex: **No! I'm an ape, by the way, not a monkey, but they eat the same things we do. Those of us who are not someone's pet or in a zoo get our nutrition by eating fruit, leaves, plants, seeds, nuts, insects, and grains. But the grains we eat come directly from the plant, not from pasta, bread, or things that people make out of them!**

As teacher: **Alex, do you know what grain spaghetti is made from?**

As Alex: **Yes, of course. Wheat is an ingredient in spaghetti. Spaghetti is one of the kinds of grain foods that we call pasta. Other types of pasta include macaroni, raviolis, and the noodles you might find in chicken-noodle soup.**

Of course, what I learned in this book today is that there are a lot more uses for spaghetti than just for food!



Vocabulary Review

- Briefly review the new theme-related vocabulary words. Use My Turn, Your Turn to have students practice saying each word. Then provide a brief definition, and make connections to the contexts in which the word was used today.



One of our new words today is “nutrition.” “Nutrition” means feeding your body with healthy foods and drinks. T-P-S: When did we see, hear, or use the word “nutrition” today?

Another word we learned is “ingredients.” When a food or dish is made up of more than one thing, we say that it is made up of ingredients. T-P-S: When did we see, hear, or use the word “ingredients” today?



- Ask partners to work together to think of a sentence that uses one of the words. Use the sharing sticks to select a student to share the sentence with the class. Use the Oral-Language Scoring Rubric to score the response. Record the score on the weekly record form.

| Oral-Language Scoring Rubric | |
|------------------------------|---------------------------------------------------------------------------------------|
| 70 | The student does not respond, or the response does not make sense. |
| 80 | The student responds with a word or phrase that makes sense. |
| 90 | The student responds in a complete sentence that makes sense. |
| 100 | The student responds in a complete sentence(s) that makes sense and includes details. |

Theme Vocabulary:
 nutrition
 ingredients

- Use the suggestions below to help foster oral-language development.

| Fostering Richer Language | | |
|----------------------------------------------------------------------------------------------------------------|------------------------------------------------------------------------------------------------------------------------------------------|----------------------------------------------------------------------------------------------------------------------------------------------------------------------------------------------|
| Student Response | Teacher Prompt | Further Prompting |
| The student responds in an incomplete sentence. Cookies ingredients. | Good answer. Can you say that in a complete sentence? | If the student is unable to respond in a sentence, model a sentence for him or her. <i>We can say, Cookies have ingredients.</i> |
| The student responds in a complete, but not very elaborate, sentence. Cookies have many ingredients. | You made a complete sentence with the word. Can you add some details to your sentence? OR Can you tell us a little more about the _____? | If the student is unable to add details, prompt with a question about the sentence. Can you tell us more about some of the ingredients you mix together when you bake cookies? |



- Award pocket points if the student is able to create a complete sentence.

Partner Challenge

- Review the Partner Challenge of the day.

We have one more opportunity to earn pocket points today! Let's review our Partner Challenge. Our Partner Challenge is to tell your partner how giving yourself a hug helps you when you feel that you are losing control.
 Allow students time to review what they told their partners earlier in the day.



- Use the sharing sticks to select students to share their responses. If you feel your students are able, have them tell their partners' responses. Award pocket points if students are able to tell how giving themselves a hug makes them feel better.
- Invite students to compliment the Cool Kid for successfully demonstrating Getting Along Together skills.

Pocket Points for the Day

- Empty the chips from KinderRoo's pouch, and encourage students to join you in counting them.
- Pour the chips into the jar, and observe how close the total is to the reward line.
- Remind students about their reward.



Home Link/Departure

- Invite students to tell their partners one thing that they did or learned today at school.
- Make any announcements or give reminders (upcoming field trips, picture day, etc.).
- Remind students to watch tonight's Home Link show. Tell students to click on the monkey for today's show.
- **Read & Respond: Share a book with someone in your family. Ask him or her to sign your Read & Respond bookmark.**
- Use the monkey stamp to place an animal image on each student's hand as a reminder to watch today's Home Link show.

Day 3 | Ready, Set...

Focus

Fruits and vegetables are needed for nutrition.

| Additional Materials Needed Today | |
|--------------------------------------------|--------------------------------------------------------------------------------------------------------------------------------------------------------------------------------------------------------------------------------------------------------------------------------------------------------------------------------------------------------------------------------------------------------------------------------------------------------------------------------------------------------------------------------------------------------------------------------------------------------------------------------------------------------------------------|
| Greetings, Readings, & Writings | <ul style="list-style-type: none"> Classroom Library Lab: Trade book: <i>More Spaghetti, I Say!</i> Literacy Lab: Key card for “ch” |
| Gathering Circle | <ul style="list-style-type: none"> No new materials |
| Theme Exploration | <ul style="list-style-type: none"> Nutrition Lotto game pieces, plastic food or real fruit and vegetables placed in a grocery bag USDA MyPlate poster Seeds from a variety of fruits (see science lab) KinderRoo puppet Theme vocabulary word card for “seeds” or IWB access |
| Rhyme Time | <ul style="list-style-type: none"> KinderCorner 2nd Edition Plus Media and Software flash drive |
| STaR | <ul style="list-style-type: none"> Trade book: <i>The Little Mouse, the Ripe Red Strawberry, and the Big Hungry Bear</i> |
| 15-Minute Math | <ul style="list-style-type: none"> Two cutouts of a foot (15-Minute Math Kit) Shorter Than/Longer Than a Foot poster (15-Minute Math Kit) |
| Snack/Outside/ Gross-Motor Play | <ul style="list-style-type: none"> Fruit or vegetable snack (Check for student food allergies, such as to strawberries, before selecting this snack.) Playground ball |
| Stepping Stones | <ul style="list-style-type: none"> Key card for “j” or IWB access “Jj” Uppercase and Lowercase Letter Card Letter-Blending Cards (“j,” “u,” “m,” p,” “ch,” “o,” “p”) or IWB access KinderRoo puppet /j/ picture cards (jacket, jam) or IWB access Common /j/ objects (optional) Stepping Stones Partner Practice Booklet for unit 6 Individual writing boards and writing implements (or pencils if writing in the Partner Practice Booklets) KinderCorner 2nd Edition Plus Media and Software flash drive Concepts-of-print book (student copies): <i>Fruit Salad</i> |

| Additional Materials Needed Today | |
|-----------------------------------|----------------------------------------------------------------------------------------------------------------------------------------------------------------------------------------------------------------------------------------------------------------------------------------------------------------------|
| Math Mysteries | <ul style="list-style-type: none"> • Colored pencils from day 2 • Who Is the Tallest? sheet (appendix), one per partnership • Scissors • Glue • Construction paper, one piece per student |
| Let's Daydream | <ul style="list-style-type: none"> • "Tutti Frutti Lovesong," <i>The 20th Century Children's Poetry Treasury</i>, page 22 |
| Write Away | <ul style="list-style-type: none"> • No new materials |
| Let's Think About It | <ul style="list-style-type: none"> • Trade book: <i>The Little Mouse, the Red Ripe Strawberry, and the Big Hungry Bear</i> • USDA MyPlate poster or IWB access • Nutrition Lotto boards and game pieces • Opaque bag or sack • Home Link animal hand stamp: koala |

Learning Labs—Additional Materials

| |
|---------------------------------------------------------------------------------------------------------------------------------------------------------------------------------------------------------------------------------------------------------------------------------------------------------------|
| Art Lab Still Life |
| <ul style="list-style-type: none"> • Assorted fruit and a bowl (for still life) • Child-Size Masterpieces (four Cézanne still life pictures); cut the postcards on the back cover apart on the dotted lines • Paint and paintbrushes |
| Literacy Lab Play School: Letter Sounds Soup |
| <ul style="list-style-type: none"> • Soup pot or large bowl • Ladle or large spoon • Plastic letters representing sounds students have learned • Small bowls or plates |
| Sand/Water Lab Harvesting Vegetables |
| <ul style="list-style-type: none"> • Garden tools such as hand shovels or trowels • Plastic or real vegetables that grow in the ground such as beets, carrots, leeks, onions, potatoes, radishes, turnips (Laminated pictures of vegetables can be substituted.) |
| Science Lab Scientist's Station: Seed Study |
| <ul style="list-style-type: none"> • Examination tools: magnifying glasses, plastic spoons, tweezers (optional) • Variety of foods that contain seeds (apple, pear, bell peppers, squash, etc.) from day 1 • Paper plates • Knife for teacher's use during the tour |

Day 3

Greetings, Readings,
& Writings

TIMING GOAL: 15 minutes

| Student Routines | Teacher Routines |
|-------------------------------------------------------------------------------------------------------------------------------------------------------------------------|----------------------------------------------------------------------------------------------------------------------------------------------------------------------------------------------------------------------------------------------------------------------------------------------------------------------------------------------------------------------------------------------------------------------------------------------------------|
| <ol style="list-style-type: none"> 1. Remove coats and backpacks. 2. Turn in homework. 3. Sign in. 4. Self-select activities. | <ol style="list-style-type: none"> 1. Greet parents and students. 2. Remind students to read the Arrival Activities poster as they prepare for their day. 3. Encourage students to describe what they are doing in full sentences as you observe their activities. 4. Observe for student progress with their individualized objectives from the weekly record form. Circle demonstrated skills if applicable. |

Homework

- Read & Respond

Available Activities

Classroom Library Lab

- Same as day 2

Literacy Lab

- Add the key card for “ch” to the lab. Encourage students to use the tactile letter-formation materials to practice forming the shape of /ch/.

Math Lab

- Same as day 2

Computer/Media Lab

- Same as day 2

Writing Lab

- Same as day 2

Other

- If you have any theme-related puzzles or games, make them available.
- Sing a transitional gathering song. Encourage students to sing along as they move to the gathering area.





Gathering Circle

TIMING GOAL: 20 minutes

Routine

1. Welcome students to the Gathering Circle.
2. Check attendance.
3. Discuss yesterday's homework assignment. Award pocket points if at least half the students completed their homework.
4. Remind students about the responsibilities associated with each classroom job as needed.
5. Make sure that students are sitting with their partners for the week.
6. Select this week's second Cool Kid.

Home Link Debrief

- Invite children to share what they remember from last night's Home Link show.



T-P-S: In last night's math video, Scooter compares the length of objects he sees. Which object is the longest? *The seesaw.*

- Use the sharing sticks to select two or three children to share their responses with the whole class. Award pocket points in recognition of successful answers.



Active Instruction

- Review the poster, and introduce the rhyme to review the Getting Along Together skill Stop and Stay Cool.

Yesterday we met Chilly the Penguin and learned the steps that he uses to stop and stay cool when he gets angry. Review the steps on the poster.

I want to teach you a rhyme that will help you remember the steps. Let's say the rhyme now. The things the rhyme tells us to do are the same things we see on the Stop and Stay Cool Steps poster with Chilly the Penguin. Recite the rhyme.

Let's all try the steps to stop and stay cool with Chilly. Invite students to stand and act out the steps to Stop and Stay Cool using the following rhyme and actions.

Stop and Stay Cool

When I'm feeling upset (Make an angry face.)

And I'm losing control (Shake fists.),

There's something I can do

So I don't get mad at you.

I stop and think! (Put your hand up in a stop signal, and pause before saying the next line.),

And give myself a hug. (Hug yourself.)

I breathe real slow (Take a deep breath and release.),

Then I'm ready to go. (Show relaxed posture.)

Distribute paper lunch sacks, the Chilly puppet outline, scissors, and glue.

Now you will get to make your very own Chilly puppet so we can practice following the Stop and Stay Cool steps. You will cut out his face and wings and glue them to the paper bag. Assist students in making the puppets as needed. Have students who finish early help other students until all are finished.

Partner Practice

- Explain the partner practice.

Now we can use our Chilly puppets to practice using Stop and Stay Cool. I will tell a little story about something that made Chilly very angry. Then you and your partner will take turns using your Chilly puppets to act out Chilly using Stop and Stay Cool to calm himself down.

- Tell the following story.

Chilly has been practicing how to ride a two-wheeled bike every day after school. Today when he was getting on the bike, his big brother came over and pulled it away from him! He said, "I'm going to ride this bike. You don't even know how to ride a two wheeler, you little baby."

Show with your face how you think Chilly feels now. Pause while students demonstrate looking angry. **Let's use our puppets to help Chilly stop and stay cool. Remember from the video that Chilly grunts and turns red when he gets mad. Some people shake when they get really mad. Make your puppet shake.**



WGR: What should Chilly do next so he doesn't get into a fight with his brother? *Stop.* Check to ensure that all students are now holding their puppets still.

WGR: What should he do next? *Give himself a Chilly hug.* Have students work with their partners to have the puppet hug himself with his wings.

WGR: What does he do next? *Slowly breathe in and out.* Guide students to open and close the puppet's mouth slowly to show that he is breathing in and out.

Now Chilly is cool and ready for school! You can always look at the Stop and Stay Cool Steps poster to help you remember the steps if you need to calm down.

Partner Challenge

- Introduce the challenge.

Today we're going to think about how taking a deep breath helps us calm down. Breathe in, 1, 2, 3, 4, 5. Breathe out. At snack time, you will talk more with your partner and tell him or her how taking a deep breath helps you calm down when you feel yourself losing control. Provide a moment for students to take a deep breath and think about how it helps them feel calm.

- Tell students they will earn pocket points when they demonstrate this step of Stop and Stay Cool while they talk with their partners.

Theme Exploration

TIMING GOAL: 15 minutes

Partnership Question of the Day



T-P-S: Do you like fruits or vegetables better? Why?

This week we are learning about the foods we need for good nutrition. Yesterday we learned about grains. Our Daily Message will tell us about some other foods that are good for our bodies.

Daily Message

Fruits and vegetables are needed for nutrition.

- Write the Daily Message in front of students, reading each word as you finish writing it. Then read the entire message again, touching each word as you read it.
- Reinforce literacy objectives by pointing out the following:
 - Ask students how many words are in the Daily Message. Invite students to clap out the words (not the syllables) with you.



Theme Learning

- Explain the content of the Daily Message.

Today we are going to learn about fruits and vegetables. Last week we learned about how fruits and vegetables grow. We know that fruits and

vegetables are parts of plants that we can eat. All types of fruits have seeds, but they may look different. Seeds come in different colors, sizes, and shapes. Pass several kinds of seeds around so students can view them. **You can use a magnifying glass to look at some more fruit seeds today in the science lab.**



- Bring out KinderRoo next to her grocery bag filled with foods from the fruit and vegetable groups. **Let's see what KinderRoo brought in her grocery bag today.** WGR: **Do you think KinderRoo has any fruits or vegetables in her bag?**
- Have KinderRoo bring the bag to a student and invite him or her to pull a food from the bag. Have students name each item as it is presented. Model the use of the name of the food in a complete sentence. Continue until all the foods have been presented. Students should hold on to their food items for the sorting activity.
- Place the USDA MyPlate poster on the floor.



Yesterday we saw how much of our plate should be filled with foods that are made from grains. Point to the grains section of the plate. **Fruits and vegetables each have a place on our plate. This is the fruits section.** Point to the fruits section in the upper-left region of the plate. **This is the vegetables section.** Point to the vegetables section in the lower-left region of the plate. T-P-S: **What do you notice about these sections? Which section is bigger—the fruits section or the vegetables section?** RWE: **The vegetables section is bigger than the fruits section, but they are both very important. Look at how much space on the plate is for fruits and vegetables. Half of the plate is for fruits and vegetables!**



- Use the sharing sticks to call on each student to rename the fruit or vegetable that he or she is holding. Restate the name of the fruit or vegetable, and share whether the food item is a fruit or a vegetable. Have each student place his or her item in the fruits or vegetables section of the plate.
- Point out the variety of fruits and vegetables on the plate.

Much of our diet should be made up of fruits and vegetables. It is a good thing we have so many wonderful fruits and vegetables to choose from each day!

- Play the digital dictionary video for “seeds.”
- Re-emphasize the theme-related vocabulary word. Post the word, or point to it on the interactive whiteboard, as you discuss it.

Our new word for today is “seeds.”

Seeds are tiny parts of plants that grow into new plants. Last week we saw seeds from pumpkins and apples in the science lab. Today you can visit the lab again to see some different kinds of seeds. I can make a sentence with the word “seeds.”

When I cut open an apple, I can see the small seeds inside it.

It is not important at this stage for students to know the difference between fruits and vegetables since many items that adults refer to as vegetables are actually fruits. It is more important for students to know, in general, which kinds of foods are healthy choices.



Ask students to stand up as they sing “It’s Time for a Rhyme” to signal the transition to Rhyme Time.

Rhyme Time

TIMING GOAL: 5 minutes

Say the Rhyme

- Have students recite “A Healthy Treat.” Encourage them to do the physical motions that accompany the rhyme.
- Read the words (see day 1), or play the video.



Develop Phonemic Awareness—Auditory Sound Segmenting

- Ask students to listen carefully to the following words. After you say each word, have them break it down to say each word in Joey Talk.

| | | | | | |
|-------------|----------|--------------|------------|-------------|----------|
| milk | /m-il-k/ | bread | /b-r-ea-d/ | meat | /m-ea-t/ |
|-------------|----------|--------------|------------|-------------|----------|



- Award pocket points if students are able to successfully produce the sounds in each word.



Sing the song “Let’s Read Together” with students.

STaR Interactive Story Reading

TIMING GOAL: 20 minutes

STaR Words:

guarding
disguised

The Little Mouse, the Red Ripe Strawberry, and the Big Hungry Bear

*Written by Don and Audrey Wood
Illustrated by Don Wood*

As the little mouse begins to pick a red ripe strawberry to eat, the clever narrator convinces the mouse otherwise. The narrator claims that the only way to save the strawberry is to share half with him so the big hungry bear won’t get it.

Interactive Story Reading

Before Reading



- Introduce the title, author, and illustrator of the story. Have students identify the author’s and illustrator’s roles and the purpose of the title.

Our story today is *The Little Mouse, the Red Ripe Strawberry, and the Big Hungry Bear*. That’s a long name for a story. WGR: What is the other word for the name of a story? *The title*. This book was written by two people, Don and Audrey Wood. WGR: What do we call the people who

write a book? *The authors.* The illustrator is Don Wood. I notice that the illustrator is also one of the authors. WGR: What other job did Don Wood do besides writing the words to the story? *Made the pictures.*

- Have students preview the story. Guide them as they make predictions about the story based on the cover illustration and the title.



Display the front cover. **The title of this story is *The Little Mouse, the Red Ripe Strawberry, and the Big Hungry Bear*. T-P-S: Whom do you think this story will be about? Let's look at some of the other illustrations and see if those pictures can help us learn more about the story before we read.**

- Take a Picture Walk through the book, stopping on several pages, such as pages 2 and 3, 12 and 13, and 22 and 23, to allow students enough time to see the illustrations. Ask students to make predictions about the story based on what they see in the illustrations.

Think aloud, **I saw the little mouse and the red ripe strawberry, but I didn't see a big hungry bear in the pictures. I wonder why I didn't see a bear. Let's read our story and find out about the bear.**

- Introduce the story vocabulary words.

In this story, we will hear two new words. One of them is “guarding.” When you are guarding something, you are watching it carefully and protecting it. T-P-S: If you have something that is important to you and you want to keep it safe, how would you guard it?

Another word is “disguised.” Something that is disguised has its looks changed so no one knows what it really is. It's like wearing a mask or a costume so people don't know who you really are.



Make predictions.

Introduce the good-reader skill for today.

To help them guess what might happen next, good readers think about what has already happened in the story. As I read the story today, think about what has happened so far. We will stop a few times and guess what we think will happen next.

During Reading



- Use Think-Pair-Share or Whole-Group Response to engage students in an ongoing discussion about the story as guided by the questions and comments below.
- As you read each page, give students time to enjoy the detailed illustrations and the mouse's wonderful expressions.
 - **Page 3:** T-P-S: **How do you think the mouse feels about picking the red ripe strawberry? Why?**
 - **Page 10:** T-P-S: **What do we know about the Big Hungry Bear? *He likes strawberries.* The mouse picks the strawberry, but he is afraid that the Big Hungry Bear will come and get it. T-P-S: What do you think will happen next?**
 - **Page 12:** Exaggerate your voice and expressions when reading “BOOM! BOOM! BOOM!” and “SNIFF! SNIFF! SNIFF!”

- **Page 17:** Think aloud, **The mouse is guarding the strawberry by watching it very carefully so no one will take it.** T-P-S: **What else does the mouse do to protect the strawberry?**
- **Page 19:** I heard our new word “**disguised**” in this part of the story. Look at the strawberry and the little mouse. They are wearing glasses and mustaches. They **disguised** themselves so no one will recognize them. Sometimes we like to dress up in costumes and pretend to be someone else. We like to **disguise** ourselves.
- **Page 22:** T-P-S: **How do you think the little mouse will save the red ripe strawberry from the big hungry bear?**
- **Page 28:** **Do you think it is a good idea to cut the strawberry in half and share it? Why (or why not)?**

After Reading

Display the last page where it says “The End.” T-P-S: **How do you think the little mouse feels now? I think the little mouse made a good, healthy choice to eat a strawberry. A strawberry is a healthy food choice because it is a type of fruit. Fruit is both delicious and good nutrition.**

WGR: **Did we see the Big Hungry Bear in this story? No. Why do you think the author didn't draw a picture of the bear?** Students may not understand that the narrator is making up the bear character so he can enjoy the delicious red ripe strawberry along with the mouse. Accept whatever responses students give. They may even say that the illustrator doesn't know how to draw a bear.

- Invite students to listen to the whole story again, concentrating on where the bear might be found. After rereading the story, ask, **Do you think the bear was real? Think aloud, I think the person who is telling the story is making up the part about the bear so the mouse will share the strawberry.**

The mouse is worried about the bear getting the strawberry, so he is protecting it. “Protecting” means the same as our new word “guarding.” Let's make a sentence together using the word “guarding.” T-P-S: **Talk to your partner about ideas that you have for our sentence.**

- Use students' ideas to develop a sentence. Write the sentence on the board in front of students, saying each word as you write it. Repeat with the word “disguised.”



Use the 1-2-3 Move signal to move students from the STaR area to the dramatic play lab for the beginning of the lab tour.



TIMING GOAL: 40 minutes

Routine

1. Have a lab tour to explain the activities or materials in any new labs.
2. Guide students as they select the lab that they will visit. Use the lab-management system to ensure that not too many students plan to visit the same lab at the same time.
3. Students will complete their Learning Lab plan. Conference with as many students as possible about their writing before they are dismissed to labs.
 - Write the code for the writing stage exhibited by the student in the top right-hand corner of the student's paper.
 - Use the methods described in the *Writing Development Feedback Guide* to provide feedback.
4. Monitor students as they visit their selected labs.

Dramatic Play Lab | KinderCorner Cafe

Description:

- The dramatic play lab will be a cafe.

When You Tour:

- Remind students that the dramatic play lab will be a cafe. Ask students what kinds of fruits and vegetables they can serve in the cafe.

Blocks Lab | Food Delivery

Description:

- Students will use the trucks to transport food to the KinderCorner Cafe.

When You Tour:

- Remind students that they can use the trucks to transport food to the KinderCorner Cafe. Ask students what kinds of fruits and vegetables they can deliver to the cafe.

Art Lab | Still Life

Description:

- Students will create still life paintings of fruit.

Purpose:

- Participation in this lab will help students to develop fine-motor skills, to reinforce the names of fruits, and to develop oral language and will provide the opportunity for them to explore art materials creatively.

When You Tour:

- Point out the paint, paintbrushes, easels, bowl of fruit, and still life paintings by Cézanne. Briefly discuss the paintings, saying, **These are still life paintings done by a famous artist, Paul Cézanne. They are called still life paintings because they are pictures of objects that don't talk or move by themselves—they are still. Today in the art lab, you may arrange the bowl and fruit and create your own still life painting like the artist Cézanne did.**

Facilitate Learning:

- Join students in painting still lifes.
- Have students evaluate their arrangement by asking themselves questions such as:
 - **Do I like where the fruit is placed?**
 - **Is this a picture that I want to paint and hang up for everyone to see?**
- Ask students to identify the colors and shapes of the fruits as they paint, even if their paintings don't look like the arrangement.

Classroom Library Lab | What's Cooking?

Description:

- Students will continue to explore books independently or with a friend. Theme-related books will be added to the regular classroom library.

When You Tour:

- Remind students that they can find cookbooks in the classroom library lab. Encourage students to look for recipes that include fruits and vegetables.

Literacy Lab | Play School: Letter Sounds Soup

Description:

- Students will play a game in which they make pretend soup and practice the sounds for letters that they have learned.

Purpose:

- This lab helps students to develop fine-motor skills and reinforces letter shapes and sounds.

When You Tour:

- Tell students that today they can come to the lab to serve up and identify the letter sounds in the alphabet soup.
- Explain that they will each take a turn stirring the soup and scooping out a letter to place in their bowls.
- Have a student take a turn stirring the soup, scooping out a letter, and making the sound of the letter.
- Have the student name something that begins with the sound of the letter that he or she has and then pass the ladle on to the next student.
- Tell students to continue in this manner, giving students multiple turns, until the soup pot is empty.

Facilitate Learning:

- Join students as they play Letter Sounds Soup. Take a turn scooping out a letter, saying the sound, and naming something that begins with that letter's sound.
- Reinforce theme-related vocabulary by using the words in questions and statements as you converse with students.

Examples:

- **This soup is a really healthy choice for lunch. Taste the soup. I can feel the energy already!**

Math Lab | Bigger or Smaller?**Description:**

- Students will sort and order objects by size.

Purpose:

- This lab provides students with an opportunity to compare the size of objects and order them from smallest to biggest.

When You Tour:

- Remind students that they are sorting objects by size. Explain that today they can pretend that they are working in an art-supply store. They are in charge of organizing the art supplies from smallest to biggest on the store shelves.

Facilitate Learning:

- Ask students to explain how they organized and ordered the objects in the math lab. Encourage them to pretend that the various objects are art supplies, using items from the Wonder Box as needed. Jump in, and join the play as you interact with students.

Examples:

- **Excuse me. I need a paintbrush that is longer than this paintbrush. Which one should I choose?**
- **Hi, I'm a new worker here at this art-supply store. I need to put these drawing pencils on the shelf in order from smallest to biggest. Can you help me?**

Computer/Media Lab | Free Exploration

Description:

- Students will continue to explore educational software or listen to music with computers, CD players, or other digital devices.

When You Tour:

- Remind students that they can explore educational software or listen to music.

Sand/Water Lab | Harvesting Vegetables

Description:

- Students will dig up vegetables the teacher has buried in the sand.

Purpose:

- This lab provides students with an opportunity to review vocabulary related to the theme and to practice numeric skills.

When You Tour:

Many vegetables grow in the ground. I wonder what kinds of vegetables you might find in our sandy garden. You can be a gardener today and dig up the vegetables.

- Suggest that students name and count the vegetables that they find. Encourage them to write the number of vegetables that they find. They can then compare to see if others have found more than, fewer than, or the same amount as they have.

Facilitate Learning:

- Join students as they dig up the vegetables.
- Talk with students about their own gardens or others they may have seen.

Examples:

- **I just dug up a potato. Have you ever grown potatoes in a garden?**
- **I wonder if we could grow corn in a garden. What do you think?**

Science Lab | Scientist's Station: Seed Study

Description:

- Students will use materials and tools to investigate seeds in fruits.

When You Tour:

- Remind students that on day 1, some of them examined the outside of the fruits they see in the lab. Today they will have the opportunity to examine the inside of each one and find the seeds.
- Cut the fruits in half as part of the lab tour.

Facilitate Learning:

- Encourage students to notice the location of the seeds in the fruit. Are the seeds attached or loose in some sort of open space?
- Invite students to extract the seeds from the fruit and lay them out on the paper plates to dry.

Teacher's Note: When cleaning up this lab, discard the fruit (or wash and serve it at snack time), but keep the seeds in the lab for examination on days 4 and 5.

Writing Lab | Healthy Helpings

Description:

- Students will continue to write, draw pictures, or glue pictures of a variety of food.

When You Tour:

- Remind students that they can create their own food plates by drawing pictures of food or by cutting out food pictures and gluing them to the plates.



Provide five-minute and three-minute warnings before the end of the labs. Then sing the clean-up song to prompt students to put away the lab items and move to the 15-Minute Math board.



15-Minute Math

TIMING GOAL: 15 minutes

Complete the following activities as described on day 1.

Calendar



- Before placing the calendar cutout on the calendar, say, **Share with your partner what you think the picture on the calendar cutout will be.** Add the calendar cutout for today's date to the calendar, and ask, **Did you know what the picture was going to be? Yes. How did you know? It's a pattern, and patterns repeat. Say the date with me. Today is** (day of the week), (month and date).

Days of the Week

Days of School Tape

Ten-Frames

Hundreds Chart

This activity will introduce students to measurement. Students will use one of the cutout feet (twelve inches long) as a reference for measurement to find objects in the classroom that are longer than or shorter than the foot shape.

Shorter/Longer Than a Foot

- Show students a foot cutout and a standard ruler. Ask them to tell you what they notice about the two objects. *They are about the same length.* Give two students each a foot cutout. Ask one of the students to find an object shorter than the foot cutout. Ask the other student to find an object longer than the foot cutout.
- When the two students have each found an object, ask them to compare the objects with the foot cutout and with each other. Ask the class to identify which object is shorter than and which object is longer than the foot cutout. Record their findings on the Shorter Than/Longer Than a Foot poster.



Recite the Stop and Stay Cool rhyme as students move to the area where you will serve the snack.



Snack • Outside • Gross-Motor Play

TIMING GOAL: 30 minutes

Snack

- Serve a fruit or vegetable snack. Ask questions that reinforce thematic vocabulary. “Is (fruit or vegetable name) an ingredient needed for a favorite recipe?” “Can you find seeds in this food?”
- Invite students to work with their partners on the Partner Challenge. **Our Partner Challenge is to tell your partner how you feel when you take a deep breath. How does it help you to feel calm?** Allow students time to talk with their partners about how they feel when they take a long, deep breath.
- Award pocket points when you observe students demonstrating one of the steps of the Stop and Stay Cool strategy.



Outside/Gross-Motor Play

- Those students who would like some structured activity may play a game of kickball. Students stand in a circle. One student starts the game by kicking the ball as he or she names a nutritious food that he or she likes to eat. For example, “I like to eat strawberries.” The person to whom the ball rolls stops it with his or her foot, kicks the ball, and says a similar sentence, naming another nutritious food. This continues as long as students remain interested. This game should be open for students to come and go during play.



TRANSITION

When students come back inside, select one student to play teacher. As students return to the gathering area for Stepping Stones, that student will point to each word on the word wall for the other students to read.



Stepping Stones

TIMING GOAL: 30 minutes

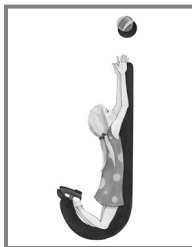

Beginning Phonics: /j/ – a bounced sound

Review

- Have students name each mnemonic picture as you point to it on the wall frieze.
- Ask students to provide the sounds for letters that have already been introduced with uppercase and lowercase cards attached.
- Show the Animated Alphabet segment for /ch/.



Introduce the New Sound

Silly Sentence

- Present the KinderRoo puppet. Explain that she has a new sound for them to learn—a sound that they will hear in the silly sentence she has brought.
- Say the alliterative phrase two or three times, emphasizing the /j/ sound at the beginning of each word by softly bouncing it.

Jane jumps for joy.

tps

- Use Think-Pair-Share to ask, **What sound do you hear at the beginning of “Jane,” “jumps,” and “joy”?**
- Explain that /j/ is a bounced sound. When we say it, we want to be careful to say it softly and quickly, like the motion of a bouncing ball. We have to be careful not to say /juh/.
- Use My Turn, Your Turn to have students repeat each of the words that begin with /j/, softly bouncing the /j/ sound at the beginning of each word.

My Turn
Your Turn

Let's practice that sound.

Teacher: /j/ ane

Students: /j/ ane

Teacher: /j/ umps

Students: /j/ umps

Teacher: /j/ oy

Students: /j/ oy

Mnemonic Picture

- Show the picture side of the key card for “j.” Explain that the picture we have to help us remember the sound /j/ is the girl, Jane.



Let's watch our funny cartoon about /j/. It will help us to remember the sound.

- Play the Animated Alphabet segment for /j/. Point out that Jane makes the /j/ sound as she jumps.

People, Pictures, and Objects

- Have KinderRoo help you identify any students whose names begin with /j/. Explain that KinderRoo has brought some pictures and objects that begin with /j/. Say the name of each picture or object as you present it, and emphasize the /j/ sound.

jacket

jam

- Ask students to name each picture or object as you point to it. Ask, **What sound do you hear at the beginning of _____?** as they name each one.



Making the Sound

- Ask students to think about what is happening in their mouths as they make the /j/ sound. Have them face their partners and make the sound several times as you ask the following questions:
 - **Is your mouth open or closed when you make the sound?**
 - **What is your tongue doing when you make the sound?**
 - **Gently touch your throat. Can you feel a vibration when you make the sound?**

Compare Uppercase and Lowercase

- Use the Uppercase and Lowercase Letter Cards to show students what both forms of the letter look like.
- Attach the uppercase and lowercase card next to the corresponding mnemonic picture on the wall frieze.



How are the two letter shapes the same? How are they different?

Partner Practice

Reading Sounds

- Distribute the Partner Practice Booklets and a crayon or pencil to each student. Ask students to open their booklets to page 2. Encourage partners to help each other find the page. Have the partners work together to read the sounds.
 - Jelly will point to the sounds, and Peanut Butter will read them. Jelly will help as needed.
 - After Peanut Butter has finished reading the sounds, Jelly will write their initials in the box at the bottom of Peanut Butter's page.
 - Peanut Butter will point to the sounds, and Jelly will read them. Peanut Butter will help as needed.
 - After Jelly has finished reading, Peanut Butter will write their initials in the box at the bottom of Jelly's page.

Stretch and Read

- Explain that the sounds we have been learning can be put together to make words. Model the process by placing the letter cards for /j/, /u/, /m/, and /p/ a few spaces apart in a pocket chart or along a chalkboard tray. Gradually move the letters closer together, and have students blend the sounds together with you until you say “jump.” Repeat with the word “chop.”

We know that words are made of sounds. We can read a word by saying all the sounds and blending them together. We call this Stretch and Read.

Alphie and his friends can use Stretch and Read to sound out words too. Let's watch.



- Show the Sound and the Furry video segment.

Now you will get to use Stretch and Read to read some words with your partner. The words you will read are different from the words we read together. Let's see who can figure out the words!

- Have students work with their partners to read the words in their Partner Practice Booklets using Stretch and Read.
- Use the sharing sticks to select a student to read the sounds for the class. Select another student to read the words. Provide assistance as needed. Award pocket points if they attempt to read all the sounds or words.



Forming the Letter

Introduce the shape of /j/.

- Explain that now you will show students how to write the letter that makes the /j/ sound. Trace the letter with your finger as you say the letter-writing cue “Down Jane’s back, up to her toes. Jump to the ball. Ask students to say the cue with you two or three times as you trace the letter again.
- Show the letter-only side of the key card. Make a connection to the letter shape and the mnemonic picture.

Example:

- **What picture does this letter look like? *Jane*. Yes, this letter looks like the girl named *Jane*.**

Write /j/.

- Demonstrate writing the letter in front of students several times on a writing board or chart paper. Ask students to say the writing cue with you as you form the letter.
- Hold the picture side of the key card next to the letters you have written. Ask students whether your letters look like Jane. Place the key card in a pocket chart with the letter side facing outward.
- Guide students to practice forming the letter shape using their fingers as pencils several times in different ways (in the air, on the carpet, on their legs, etc.). Encourage them to say the cue as they write the letter.
- Distribute individual whiteboards and dry-erase markers, chalkboards and chalk, or paper and pencils or crayons. You may also use the space provided in the Partner Practice Booklet for writing. Ask students to write /j/ several times, reciting the cue with them each time.
- Ask students to examine their partners’ letters for /j/ and circle the best one. Encourage them to tell their partners why they think it’s the best.
- Have students write other letters that they have learned. Encourage them to say the cue as they write each letter.
 - /z/ **Zig right, zag left, zig right.**
 - /h/ **From head to toe and over his back.**
- Include other review letters as needed by your students.

Stretch and Count/Stretch and Spell

- Call out a word, and ask students to break it down as they count the number of sounds in the word on their fingers. Ask them to draw a line for each sound that is represented in the word. Say the sounds in the word again, and have students write the letters that make the sounds on the lines to spell the word.

jump

chop

- Collect the Partner Practice Booklets.

Emergent Reading

Story Introduction

- Show the cover of *Fruit Salad*. Introduce the title and author.

Today we will read a story about a healthy food that can be made with many different pieces of fruit—yum! We know that fruits and vegetables are needed for good nutrition.

- Introduce the focus skills for the story.

There is a word from our word wall in this book. Let's review all the words. Quickly point to each word, and have students read it in unison. Point to the word “we.” **We will see the word “we” on every page of our book.**

There is another word in our book that we can stretch and read. Write “cut” on the board. Invite students to stretch and read the word.

- Remind students that the pictures will help them read the other words in the book.

Guided Group Reading

- Distribute a book to each student. Read the book again, this time inviting students to read in unison with you as they follow along in their own books.



Invite students to sing “March to Math” to signal that it is time for Math Mysteries.



Math Mysteries

TIMING GOAL: 25 minutes

Show What You Know

- Hold up the three pencils from yesterday. Do not put them in order by size. Line up the ends so students can compare them.



T-P-S: Which pencil is the longest? How can you tell?

RWE: The blue pencil is the longest. If I line up the ends, I can see that it is taller than the other two pencils.



- Award pocket points if students are able to tell that the blue pencil is the longest.
- Ask students to sit with their partners in a circle so they can see the space in front of you.

T-P-S: Think about what you learned during the last math time. What do you know about ordering objects by size?

RWE: When we order objects by size, we need to line up the ends and compare them to see which is shortest, longest, and in between.

Active Instruction



- Quickly place students into groups of three. Ask each group to line themselves up in order according to height. Ask students how they decided who in their group was the tallest, the next tallest, and then the shortest.
- Select one group of three students to come to the front with you. Explain how to order them from tallest to shortest.

When we order people from tallest to shortest, we are putting them in order by their height. First, we need to make sure that everyone's feet are lined up in the same spot. Then, we can decide which person is the tallest, or whose head sticks up higher than everyone else's. Point to the tallest student, and move him or her to one side. **Next, we can decide which one is the next tallest.** Point to this student, and move him or her beside the tallest student. **After that, we know which person is the shortest.** Point to this student, and move him or her to the end of the line. **Now they are in order by height, from tallest to shortest.**

- Tell students that they will practice putting things in order by height.

Partner Practice



- Give each student a Who Is the Tallest? sheet and a piece of construction paper.

T-P-S: What can you tell me about the pictures on this sheet? *There are pictures of children on this sheet. The children are different sizes.*

- Explain to students that they will cut out the pictures of the students on the sheets along the dotted lines and then discuss with their partners how to arrange them in

order by height on the construction paper. Ask students to check their partners' work before gluing the pictures down.

- Remind students to glue the pictures to the paper so the feet of each child pictured are on the bottom edge of the construction paper.
- Assist those students who might be struggling with cutting or gluing. As they finish, ask them to point to the picture of the tallest child, the next-tallest child, and the shortest child.

Recap



- Use the sharing sticks to select a few students to share how they ordered their pictures. Award pocket points if several students are able to successfully explain how they ordered their pictures.
- Review how to order objects.

T-P-S: Let's pretend that we are getting a class picture taken and that the photographer wants us to line up from tallest to shortest. How would we do that? *We would need everyone to stand in a line. Then, we could pick out the tallest student. Then, we would pick out the next-tallest student and the next tallest after that until we had everyone in order from tallest to shortest.*



TRANSITION

Sing "It's time to go to sleep. It's time to count our sheep." Then count in a quiet voice, touch each student lightly on the head, and send them to retrieve their nap-time supplies.

Let's Daydream

TIMING GOAL: 25 minutes

Routine

1. Have students get out their supplies (towels, cots, etc.) for nap time.
2. Read the selected poetry, and play soft music (optional) as students rest.
3. Allow students to quietly look at another book during this time if they prefer.

Recommended Poetry Selection

- "Tutti Frutti Lovesong," *The 20th Century Children's Poetry Treasury*, page 22

Introduce the Poem

Today I am going to read a silly poem that has many different fruits mentioned in it. Listen to see if you can hear the names of all the fruits.



TRANSITION

Gather students in a place where you will model during Write Away.



Write Away

TIMING GOAL: 20 minutes

Prewriting

- Present the writing topic for the day, and encourage students to share their ideas. To discourage copying later, do not write the ideas on the board.

Today we have been talking about fruits and vegetables. We know that we need fruits and vegetables for good nutrition. You are going to write about a kind of fruit or vegetable that you eat for lunch.



What kind of fruit or vegetable do you eat with your lunch?

- Share an example that applies to you.

I think that I will write a sentence that says, “I like carrots with my lunch.”

- Review previously introduced emergent-writing strategies.

T-P-S: What are some things that I can do if I don't know how to write some of the words in my sentence? Draw a picture, draw a line, write sounds that I know, copy a word, and remember a word.

I will use these things to write my sentence. You can use them when you write your sentence too.

- Use previously introduced writing strategies to model writing your sentence.

First, count the words on your fingers as you say the sentence again. Then, draw lines on the board to represent each word.

Example:

I am ready to write my sentence. My sentence is, “I like carrots with my lunch.”

- **The first word is “I.” I can copy that word because it is on the word wall. Remember that when we write the word “I,” it is always a capital, or uppercase, letter like it is written on the word wall. Write “I” on the first line.**
 - **The next word is “like.” I remember that word from writing it yesterday. Write “like.”**
 - **“Carrots.” What sounds do you hear in “carrots”? Say the word slowly, emphasizing the individual sounds. Write any letters that students say.**
 - **“I like carrots with my lunch.” The next word is “with.” I also remember how to write that word. Write “with.”**
 - **“My.” That word is also on the word wall, so I can copy it. Write “my.”**
 - **The last word is “lunch.” I hear some sounds that we've learned in “lunch.” I hear /l/, /n/, and the sound we just learned, /ch/. Write each sound as you say it on the last line.**
- Reread your sentence, touching each word, or word representation, as you do.

Partner Planning

- Ask students to share what they would like to write with their partners. Encourage them to use the Say-It-Back strategy to show their partners that they are listening.
- Monitor students, and listen to their discussions. Ask one or two students what their partners are planning to write.

Writing

- Distribute pencils and either writing journals or paper.
- Monitor students as they write. Encourage them to use the writing strategies that you have introduced as needed.
- Hold a writing conference with a few students if time permits. On the weekly record form, record the stage of writing that you observe for each of these students.

Sharing



- Ask students to share their sentences with their partners.
- Use the sharing sticks to select one or two students to share their writing with the class. Acknowledge and celebrate any emergent-writing strategies that they have used.



Invite students to recite or sing “Let’s Think About It” as they move to the gathering area.



Let's Think About It

TIMING GOAL: 20 minutes

Theme-Learning Recap



- Review the learning focus of the day.

We’ve talked about fruits and vegetables today. T-P-S: Do you remember what all fruits have in common? *Fruits have seeds.* RWE: Yes, fruits have seeds, and vegetables don’t. Sometimes it is hard to tell which items are fruits and which are vegetables. Sometimes we call fruits vegetables.

- Display the book *The Little Mouse, the Red Ripe Strawberry, and the Big Hungry Bear*. T-P-S: **What did the mouse eat in our story? *A strawberry.* Is a strawberry a fruit or a vegetable? *Fruit.* Yes. Strawberries are fruits because they have seeds.**
- Invite students who visited the writing lab today to bring their plates to the front of the room. Identify any fruits or vegetables that were found.

- Display the USDA MyPlate poster.

The plate and glass on this placemat are a food guide. T-P-S: How does this food guide help us? It helps us understand the different kinds of foods we need to eat so we can be strong and healthy. Let's all point to the place on the plate where we put the foods made with grains.

- Review food names and food groups by playing Nutrition Lotto.

Divide students into six groups. Give each group a Nutrition Lotto board. Place the game pieces in a bag, and pull out one piece at a time. Each time you draw a piece, ask, **Which group has the** (name of the food in the picture on the game piece)? Have students raise their hands if the food item is on their board.

Give the game piece to the group to place on the matching picture on their lotto board. Have the class say a complete sentence with you that identifies the food group that the item belongs in. (For example, "Milk is in the dairy group.")

Give a cheer to the group that covers all six pictures on their game card first.



Vocabulary Review

- Briefly review the new theme-related vocabulary word. Use My Turn, Your Turn to have students practice saying the word. Then provide a brief definition, and make connections to the contexts in which the word was used today.



Our new word today is "seeds." Seeds are tiny parts of plants that grow into new plants. T-P-S: When did we see, hear, or use the word "seeds" today?



- Ask partners to work together to think of a sentence that uses the word. Use the sharing sticks to select a student to share the sentence with the class. Use the Oral-Language Scoring Rubric to score the response. Record the score on the weekly record form.

| Oral-Language Scoring Rubric | |
|------------------------------|---------------------------------------------------------------------------------------|
| 70 | The student does not respond, or the response does not make sense. |
| 80 | The student responds with a word or phrase that makes sense. |
| 90 | The student responds in a complete sentence that makes sense. |
| 100 | The student responds in a complete sentence(s) that makes sense and includes details. |

Theme Vocabulary:
seeds

- Use the suggestions below to help foster oral-language development.

| Fostering Richer Language | | |
|------------------------------------------------------------------------------------------------------|------------------------------------------------------------------------------------------------------------------------------------------|--------------------------------------------------------------------------------------------------------------------------------------------------------|
| Student Response | Teacher Prompt | Further Prompting |
| The student responds in an incomplete sentence. Pumpkin seeds. | Good answer. Can you say that in a complete sentence? | If the student is unable to respond in a sentence, model a sentence for him or her. <i>We can say, Pumpkins have seeds.</i> |
| The student responds in a complete, but not very elaborate, sentence. Pumpkins have seeds. | You made a complete sentence with the word. Can you add some details to your sentence? OR Can you tell us a little more about the _____? | If the student is unable to add details, prompt with a question about the sentence. Can you tell us more about what pumpkin seeds look like? |



- Award pocket points if the student is able to create a complete sentence.

Partner Challenge

- Review the Partner Challenge of the day.

We have one more opportunity to earn pocket points today! Let's review our Partner Challenge. Our Partner Challenge is to tell your partner how you feel when you take a deep breath. How does it help you to feel calm?

Allow students time to review what they told their partners earlier in the day.



- Use the sharing sticks to select students to share their responses. If you feel your students are able, have them tell their partners' responses. Award pocket points when students tell how taking a deep breath helps them to feel calm.
- Invite students to compliment the Cool Kid for successfully demonstrating Getting Along Together skills.

Pocket Points for the Day

- Empty the chips from KinderRoo's pouch, and encourage students to join you in counting them.
- Pour the chips into the jar, and observe how close the total is to the reward line.
- Remind students about their reward.



Home Link/Departure

- Invite students to tell their partners one thing that they did or learned today at school.
- Make any announcements or give reminders (upcoming field trips, picture day, etc.).
- Remind students to watch tonight's Home Link show. Tell students to click on the koala for today's show.
- **Read & Respond: Share a book with someone in your family. Ask him or her to sign your Read & Respond bookmark.**
- Use the koala stamp to place an animal image on each student's hand.

Day 4 | Ready, Set...

Focus

Dairy and protein are needed for nutrition.

| Additional Materials Needed Today | |
|--------------------------------------------|---------------------------------------------------------------------------------------------------------------------------------------------------------------------------------------------------------------------------------------------------------------------------------------------------------------------------------------------------------------------------------------------------------------------------------------------------------------------------------------------------------------------------------------------------------------------------------------------------------------------------------------------------------------------------------------|
| Greetings, Readings, & Writings | <ul style="list-style-type: none"> Classroom Library Lab: Copies of the concepts-of-print book <i>Fruit Salad</i> and the trade book <i>The Little Mouse, the Red Ripe Strawberry, and the Big Hungry Bear</i>, ear and mouth cards Literacy Lab: Key card for “j” Other: Nutrition Lotto boards and game pieces |
| Gathering Circle | <ul style="list-style-type: none"> Stop and Stay Cool Steps poster or IWB access |
| Theme Exploration | <ul style="list-style-type: none"> Nutrition Lotto, dramatic play, or real dairy and protein items placed in a grocery bag USDA MyPlate poster KinderRoo Theme vocabulary word cards for “dairy” and “protein” or IWB access |
| Rhyme Time | <ul style="list-style-type: none"> KinderCorner 2nd Edition Plus Media and Software flash drive |
| STaR | <ul style="list-style-type: none"> Trade book: <i>The Little Mouse, the Red Ripe Strawberry, and the Big Hungry Bear</i> <i>The Little Mouse, the Red Ripe Strawberry, and the Big Hungry Bear</i> Sequencing Cards (appendix) |
| 15-Minute Math | <ul style="list-style-type: none"> No new materials |
| Snack/Outside/ Gross-Motor Play | <ul style="list-style-type: none"> Dairy or protein food Beanbags Pictures of foods from the groups introduced so far |
| Stepping Stones | <ul style="list-style-type: none"> Key card for “v” or IWB access “Vv” Uppercase and Lowercase Letter Card Letter-Blending Cards (“v,” “e,” “s,” “t,” “j,” “a,” “m”) or IWB access KinderRoo puppet /v/ picture cards (van, vegetables, violin) or IWB access Common /v/ objects (optional) Stepping Stones Partner Practice Booklets for unit 6 Individual writing boards and writing implements (or pencils if writing in the Partner Practice Booklets) KinderCorner 2nd Edition Plus Media and Software flash drive Concepts-of-print book (student copies): <i>Fruit Salad</i> |

| Additional Materials Needed Today | |
|-----------------------------------|------------------------------------------------------------------------------------------------------------------------------------------------------------------------------------------------------------------------------------------------------------------------------------------------------------------------------------------|
| Math Mysteries | <ul style="list-style-type: none"> • Crayon Tape Measure (appendix), one per partnership • Body Measurement Sheet (appendix), one per student |
| Let's Daydream | <ul style="list-style-type: none"> • "The Gentle Cow," <i>The 20th Century Children's Poetry Treasury</i>, page 8 |
| Write Away | <ul style="list-style-type: none"> • No new materials |
| Let's Think About It | <ul style="list-style-type: none"> • USDA MyPlate poster • Glue • Single pages from magazines with pictures of food items from the dairy and protein groups (one per partnership) • Marker • Scissors (optional), one per partnership • Home Link animal hand stamp: leopard |

Day 4

Greetings, Readings,
& Writings

TIMING GOAL: 15 minutes

| Student Routines | Teacher Routines |
|-------------------------------------------------------------------------------------------------------------------------------------------------------------------------|----------------------------------------------------------------------------------------------------------------------------------------------------------------------------------------------------------------------------------------------------------------------------------------------------------------------------------------------------------------------------------------------------------------------------------------------------------|
| <ol style="list-style-type: none"> 1. Remove coats and backpacks. 2. Turn in homework. 3. Sign in. 4. Self-select activities. | <ol style="list-style-type: none"> 1. Greet parents and students. 2. Remind students to read the Arrival Activities poster as they prepare for their day. 3. Encourage students to describe what they are doing in full sentences as you observe their activities. 4. Observe for student progress with their individualized objectives from the weekly record form. Circle demonstrated skills if applicable. |

Homework

- Read & Respond

Available Activities

Classroom Library Lab

- Display *The Little Mouse, the Red Ripe Strawberry, and the Big Hungry Bear* in a prominent place in the library. Invite students to explore the book. Also place a few copies of *Fruit Salad* in the lab. Encourage students to practice reading the books with a friend.

Literacy Lab

- Add the key card for “j” to the lab. Encourage students to use the tactile letter-formation materials to practice forming the shape of /j/.

Math Lab

- Same as day 3

Computer/Media Lab

- Same as day 3

Writing Lab

- Same as day 3

Other

- Put out the Nutrition Lotto game materials, and encourage students to play the game together.



Sing a transitional gathering song. Encourage students to sing along as they move to the gathering area.

Gathering Circle

TIMING GOAL: 15 minutes

Routine

1. Welcome students to the Gathering Circle.
2. Check attendance.
3. Discuss yesterday's homework assignment. Award pocket points if at least half the students completed their homework.
4. Remind students about the responsibilities associated with each classroom job as needed.
5. Make sure that students are sitting with their partners for the week.
6. Remind students about the responsibilities of the Cool Kid.

Home Link Debrief



- Invite children to share what they remember from last night's Home Link show.
T-P-S: What did you find that begins with the letter "j" in your house?
- Use the sharing sticks to select two or three children to share their responses with the whole class. Award pocket points in recognition of thoughtful answers.

Partner Challenge

We learned a good way to calm down when we get angry, so angry that we could mark a Feelings Thermometer at a 5. We can do what Chilly taught us—stop and stay cool. Our Partner Challenge today is to show your partner all the Stop and Stay Cool steps that you take when you feel angry because someone broke your favorite toy.

- Provide a moment for students to think about the steps of Stop and Stay Cool. You may want to remind them that the poster will help them with this challenge. And, of course, their partners can help them too.
- Tell students they can earn pocket points when they show all the steps of Stop and Stay Cool.

Brain Game

- Review the game.

We play our Brain Games to help us exercise our mind muscles. Our game this week is Simon Says. When we play this game, we use our mind

muscles to stop and think. Give the Stop and Think signal (one hand held out to make a stop sign and the other hand pointing to your head).

Play the game. To challenge students, demonstrate all the actions, both those preceded by the words “Simon says” and those that are not. As students make mistakes, do not exclude them; simply start over again with a new set of instructions. The intention is not to penalize students when they make mistakes, but to encourage them to work on the cognitive-regulation skill in a way that is fun.

Theme Exploration

TIMING GOAL: 15 minutes

Partnership Question of the Day



T-P-S: To keep our bodies well, we need to eat healthy foods. What other things can we do to keep our bodies feeling good?

Those are some great ideas! Let's see what our Daily Message tells us about nutrition today.

Daily Message

Dairy is needed for nutrition.

Protein is needed for nutrition.

- Write the Daily Message in front of students, aligning the words in the second sentence under the same words in the first sentence. Read each word as you finish writing it. Then read the entire message again, touching each word as you read it.
- Reinforce literacy objectives by pointing out the following:
 - WGR: **How many sentences do we have in our Daily Message? Two. How do you know where a sentence begins? It begins with an uppercase letter.**
 - WGR: **What mark do you see at the ends of both of these sentences? A period.**
 - T-P-S: **Look at both sentences to see if you can find some words that are the same. "...is needed for nutrition." Which words are different? "Dairy" and "protein." How do you know which sentence has the word "dairy" in it? "Dairy" begins with /d/. Circle the "d" in "dairy." How do you know which sentence has the word "protein" in it? "Protein" begins with /p/. Circle the "p" in "protein."**



Theme Learning

- Explain the content of the Daily Message.

Today we are going to learn about foods that are part of the dairy group and foods that are part of the protein group.

Dairy foods are the milk of animals such as cows and goats or the foods made from milk. Cheese and yogurt are made from milk.

Protein foods are meats and other foods from animals such as chickens, pigs, fish, turkey, and cows. We get protein from plants too. Nuts and dry beans give us protein. Peanut butter is made from nuts, so we get protein from peanut butter.



- Bring out KinderRoo next to her grocery bag filled with foods from the dairy and protein groups. T-P-S: **I wonder what kinds of foods KinderRoo brought today. Turn to your partner, and tell what you think KinderRoo might have brought to share.**

Let's take turns reaching into KinderRoo's bag to see what she has brought.

- Have students take turns selecting and presenting an item for the rest of the class to see. Have students name each item that is presented. If an item is unfamiliar to students, name the item, and have students repeat the name after you. Students should hold onto their food items for the sorting activity.
- Place the USDA MyPlate poster on the floor. Point to the grains section of the plate.



WGR: Do you remember when we talked about grains? Yes. We said that grains are the seeds or the fruit part of grasses. These seeds are edible. "Edible" means that we can eat them. The grains group is made up of foods such as bread, rice, and pasta.

- Point to the fruits and vegetables sections of the plate.

When we talked about fruits and vegetables, we said that they are the parts of plants that we can eat. Fruits and vegetables should take up half of the space on your plate.

- Show students the protein section of the plate. Point out that this section is slightly smaller than the grains and vegetables sections.
- Show students the dairy section. Explain that the dairy section is like a cup because you can drink milk, and dairy products are made from milk.



- Use the sharing sticks to call on each student to rename the food item that he or she is holding. Restate the name of the food if needed. Have students place their items in the dairy or protein sections of the plate. Assist students who need help identifying whether their foods belong in the dairy section or the protein section. As each item is placed on the plate or cup, make a simple statement informing students where the product comes from. For example, "Milk comes from a cow," "Beans come from a plant," or "Ham comes from a pig."

Teacher's Note: Some students may not have lactose-based dairy products in their diets. You may wish to explain that not all milk comes from cows and that some milk, such as soy milk and almond milk, comes from plants and nuts. Dairy products such as cheese and ice cream are made from these other types of milk in addition to cow's milk.



- Play the digital dictionary videos for "dairy" and "protein."
- Re-emphasize the theme-related vocabulary words. Post the words, or point to them on the interactive whiteboard, as you discuss each one.

Our new words for today are “dairy” and “protein.”

Dairy describes milk and foods made from milk. Butter, cheese, yogurt, and ice cream are all dairy products. I can make a sentence with the word “dairy:”

I buy cheese from the dairy section of the grocery store.

Protein products come from plants and animals. Meat is a good source of protein. Eggs and nuts are also good sources of protein. I can make a sentence with the word “protein:”

I eat eggs for breakfast to help my body get protein.



Ask students to stand up as they sing “It’s Time for a Rhyme” to signal the transition to Rhyme Time.

Rhyme Time

TIMING GOAL: 10 minutes

Say the Rhyme

- Have students recite “A Healthy Treat.” Encourage them to do the physical motions that accompany the rhyme.
- Read the words (see day 1), or play the video.



Develop Phonological Awareness—Recognizing Alliteration

Introduce the activity to students.

Today we are going to play a game with beginning sounds. I am going to say the words in the rhyme and ask you to listen for words that begin with the same sound. If you hear the sound that I am asking you to listen for, put your hands on your head. Demonstrate. If you hear different sounds, leave your hands in your lap.



- Practice the activity with the /s/ sound.

Let’s practice with a few words first. Listen for the /s/ sound. If you hear /s/ at the beginning of a word, put your hands on your head. Be careful because I’m pretty tricky. Ready? WGR: Socks. Hands on head. Sandwich. Hands on head. Jelly. Hands in lap.

- Practice the activity with the /d/ sound.

Let’s try a few more words. This time I want you to listen for the sound /d/. Ready? WGR: Department. Hands on head. Food. Hands in lap. Dog. Hands on head.

- Tell students to listen for the sounds /r/ and /m/ as you read the first stanza of the rhyme.

Let's listen to more words as I read the rhyme. Remember to put your hands on your head when you hear the sound that I ask you to listen for. First, I want you to listen for the sound /r/. Ready? Read the first three lines of the rhyme, "To keep our bodies... and some rice." WGR: **Which words started with /r/?** "*Raspberries,*" "*raisins,*" and "*rice.*"

Listen for the sound /m/ this time. Read the last line of the first stanza. WGR: **Which words started with /m/?** "*Mushrooms,*" "*milk,*" and "*meat.*"

- Before reading the entire second stanza, tell students to listen for the /c/ sound. Read the second stanza, and ask students which words started with /k/. "*Carrots,*" "*corn,*" "*cabbage,*" "*cauliflower,*" "*cut,*" and "*cooked.*"
- When reading the third stanza, tell students to listen for the /p/ sound.
- When reading the fourth stanza, tell students to listen for /b/ in the first line and /m/ in the second line.
- Congratulate students for their careful listening.
- Award pocket points if several students are able to successfully identify words in the rhyme that have the requested initial sound.



TRANSITION

Sing the song "Let's Read Together" with students.



TIMING GOAL: 20 minutes

Review



- Review the title, author, and illustrator.

We read this story yesterday. Do you remember the title? The Little Mouse, the Red Ripe Strawberry, and the Big Hungry Bear.

WGR: The authors are Don and Audrey Wood. What does the author do? *The author thinks of the story, writes the words.*

WGR: The illustrator is Don Wood. What does the illustrator do? *The illustrator paints, draws, and creates the pictures.*

- Review the story vocabulary words. Show the word on a word card or on the interactive whiteboard as you refer to it. Invite partners to make a sentence with each word.



We learned some new words in our story yesterday. The first word was "guarding." What does "guarding" mean? *Carefully watching.*

T-P-S: Can you think of a sentence that uses the word "guarding"? Work with your partner to think of a sentence.



- Use the sharing sticks to select students to share their responses. Award pocket points for successful responses.

- Repeat this process with the word “disguised.” *The word “disguised” means something changed its looks.*

Story Retell

- Tell students they will use sequencing cards to retell the story *The Little Mouse, the Red Ripe Strawberry, and the Big Hungry Bear*.

After I read the story *The Little Mouse, the Red Ripe Strawberry, and the Big Hungry Bear* again today, we will use sequencing cards to put the story in order.

- Reread the story without stopping to ask interactive questions.
- Form groups of four students by combining partnerships. Distribute a set of sequencing cards to each group of students. Keep a set of cards so you can place them in sequential order from left to right after students identify the correct sequence.

These cards will help you remember what happens in the story. Talk with your friends about what each picture reminds you of in the story. Allow time for students to describe what's depicted on the cards within their groups. **You will work with your group to put these cards in the order in which things happen in the story.**

- If students need support with this activity, ask guiding questions to help them sequence the cards. After you ask questions, allow students time to talk with the members of their groups about what's pictured on each card before proceeding.

Questions may include:

- **Which picture reminds you about what happens first in the story?**
 - **What does the mouse do after he picks the strawberry?**
 - **How does the mouse try to guard the strawberry?**
 - **What other way does the mouse try to keep the bear from finding the strawberry?**
 - **What does the mouse finally decide to do with the strawberry?**
 - **What happens at the end of the story?**
- As students identify the sequence of events in the story, model placing the cards in order from left to right.
 - Close the activity by asking students if they think the mouse makes a good decision about sharing the strawberry. T-P-S: **Do you think the mouse is smart to share the strawberry with the person telling the story? Why (or why not)?**



Use the 1-2-3 Move signal to move students from the STaR area to the dramatic play lab for the beginning of the lab tour.



TIMING GOAL: 40 minutes

Routine

1. Have a lab tour to explain the activities or materials in any new labs.
2. Guide students as they select the lab that they will visit. Use the lab-management system to ensure that not too many students plan to visit the same lab at the same time.
3. Students will complete their Learning Lab plan. Conference with as many students as possible about their writing before they are dismissed to labs.
 - Write the code for the writing stage exhibited by the student in the top right-hand corner of the student's paper.
 - Use the methods described in the *Writing Development Feedback Guide* to provide feedback.
4. Monitor students as they visit their selected labs.

Dramatic Play Lab | KinderCorner Cafe

Description:

- The dramatic play lab will be a cafe.

When You Tour:

- Remind students that the dramatic play lab will be a cafe. Ask students what kinds of dishes with dairy and protein they can serve in the cafe.

Blocks Lab | Food Delivery

Description:

- Students will use the trucks to transport food to the KinderCorner Cafe.

When You Tour:

- Remind students that they can use the trucks to transport food to the KinderCorner Cafe. Ask students what kinds of dairy and protein foods they can deliver to the cafe.

Art Lab | Still Life

Description:

- Students will continue to create still life paintings of fruit.

When You Tour:

- Remind students that they can paint pictures of the fruit.

Classroom Library Lab | What's Cooking?

Description:

- Students will have the opportunity to explore books independently or with a friend. Theme-related books will be added to the regular classroom library.

When You Tour:

- Remind students that they can find cookbooks in the classroom library lab. Encourage students to look for recipes that include dairy and protein.

Literacy Lab | Play School: Letter Sounds Soup

Description:

- Students will continue to have the opportunity to play a game in which they make pretend soup and practice sounds for the letters they have learned.

When You Tour:

- If needed, remind students how to play the game.

Facilitate Learning:

- Reinforce theme-related vocabulary by using the words as you converse with students.

Examples:

- What **ingredients** do you have in your soup?
- Soup is a healthy food. It provides good **nutrition**.

Math Lab | Bigger or Smaller?

Description:

- Students will sort and order objects by size.

Purpose:

- This lab provides students with an opportunity to compare the size of objects and order them from tallest to shortest.

When You Tour:

- Remind students that they are sorting objects by size. Explain that today they can pretend that they are photographers. They need to line up the objects that they want to photograph from tallest to shortest. They can use objects or people. They should draw pictures of the objects that they ordered from tallest to shortest to serve as their photographs.

Facilitate Learning:

- Ask students to explain how they organized and ordered the objects in the math lab. Jump in, and join the play as you interact with students.

Examples:

- **I need a picture taken of my three children. Can you order them from tallest to shortest and take their picture?**
- **I'm new to taking pictures; I hear that photographs look best when objects are ordered from tallest to shortest. What should I take a picture of, and how can I order the objects?**

Computer/Media Lab | Free Exploration

Description:

- Students will continue to explore educational software or listen to music with computers, CD players, or other digital devices.

When You Tour:

- Remind students that they can explore educational software or listen to music.

Sand/Water Lab | Harvesting Vegetables

Description:

- Students will continue to dig up vegetables that the teacher has buried in the sand.

When You Tour:

- Remind students that they can dig up vegetables that the teacher has buried in the sand.

Science Lab | Scientist's Station: Seed Study

Description:

- Students will use examination tools to investigate seeds from fruits.

When You Tour:

- Explain that students can examine, describe, and record information about seeds.

Writing Lab | Healthy Helpings

Description:

- Students will continue to write, draw pictures, or glue pictures of a variety of foods.

When You Tour:

- Remind students that they can create their own food plates by drawing pictures of food or cutting out food pictures and gluing them to the paper plates. Ask students what dairy or protein dishes they can put on their plates.



Provide five-minute and three-minute warnings before the end of the labs. Then sing the clean-up song to prompt students to put away the lab items and move to the 15-Minute Math board.



15-Minute Math

TIMING GOAL: 15 minutes

Complete the following activities as described on day 1.

Calendar

Days of the Week

Days of School Tape

Ten-Frames

Hundreds Chart

Shorter Than /Longer Than a Foot

- Ask students if they remember what you recorded on the Shorter Than/Longer Than a Foot poster yesterday. *One object that was shorter than a foot and one object that was longer.* Ask students to look around the room and think about something that is shorter than a foot and something that is longer. Select one student to find an object that is shorter than the foot cutout. Select another student to find an object that is longer than the foot cutout. When the two students have each found an object, ask them to compare the objects with the foot cutout and to each other's objects. Ask the class to identify which object is shorter than the foot cutout and which object is longer. Record their findings on the Shorter Than/Longer Than a Foot poster.



Recite the Stop and Stay Cool rhyme as students move to the area where you will serve the snack.



Snack • Outside • Gross-Motor Play

TIMING GOAL: 30 minutes

Snack

- Serve a dairy or protein food today such as yogurt or peanut butter. Talk with students about the food they are eating, encouraging them to use the new vocabulary introduced in the unit. Help them to express why this is a good food for them to eat (e.g., “It makes my body strong.” “It helps me have strong muscles and bones.” “It makes me healthy.”).

- Invite students to talk with their partners about the challenge. **Your Partner Challenge today is to show your partner all the Stop and Stay Cool steps that you can take when you feel angry because someone broke your favorite toy.** Allow students time to think about the steps and then demonstrate for their partners. Encourage partners to help each other remember the parts.



- Award pocket points when you observe students demonstrating all the steps of Stop and Stay Cool.

Outside/Gross-Motor Play

- Take some beanbags and some pictures of foods (cut from magazines) from the various groups that students have learned about, and bring them outside with you.
- Place the pictures of foods randomly on the ground. Have students take turns tossing the beanbags onto the pictures while naming the foods at which they are aiming. Encourage them to use complete sentences. Model for them. For example, “I am aiming at the oranges. Oranges are good for you.” “Bananas are a healthy fruit to eat.”



TRANSITION

When students come back inside, select one student to play teacher. As students return to the gathering area for Stepping Stones, that student will point to each word on the word wall for the other students to read.

Stepping Stones

TIMING GOAL: 30 minutes



Beginning Phonics: /v/ – a stretched sound

Review

- Have students name each mnemonic picture as you point to it on the wall frieze.
- Ask students to provide the sounds for letters that have already been introduced with uppercase and lowercase cards attached.
- Show the Animated Alphabet segment for /j/.



Introduce the New Sound

Silly Sentence

- Present the KinderRoo puppet. Explain that she has a new sound for them to learn—a sound that they will hear in the silly sentence she has brought.
- Say the alliterative phrase two or three times, emphasizing the /v/ sound at the beginning of each word by stretching or extending it.

The vulture veers over valleys.



- Use Think-Pair-Share to ask, **What sound do you hear at the beginning of “vulture,” “veers,” and “valleys”?**
- Explain that /v/ is a stretched sound. We can make it longer without bouncing it.



- Use My Turn, Your Turn to have students repeat each of the words that begin with /v/, stretching the /v/ sound at the beginning of each word.

Let's practice that sound.

Teacher: /v/ ulture

Students: /v/ *ulture*

Teacher: /v/ eers

Students: /v/ *eers*

Teacher: /v/ alleys

Students: /v/ *alleys*

Mnemonic Picture

- Show the picture side of the key card for “v.” Explain that the picture we have to help us remember the sound /v/ is a vulture.



Let's watch our funny cartoon about /v/. It will help us to remember the sound.

- Play the Animated Alphabet segment for /v/. Point out that the vulture makes the /v/ sound as it flies.

People, Pictures, and Objects

- Have KinderRoo help you identify any students whose names begin with /v/. Explain that KinderRoo has brought some pictures and objects that begin with /v/. Say the name of each picture or object as you present it, and emphasize the /v/ sound.

van

vegetables

violin

- Ask students to name each picture or object as you point to it. Ask, **What sound do you hear at the beginning of _____?** as they name each one.



Making the Sound

- Ask students to think about what is happening in their mouths as they make the /z/ sound. Have them face their partners and make the sound several times as you ask the following questions:
 - **Is your mouth open or closed when you make the sound?**
 - **What is your tongue doing when you make the sound?**
 - **Gently touch your throat. Can you feel a vibration when you make the sound?**

Compare Uppercase and Lowercase

- Use the Uppercase and Lowercase Letter Cards to show students what both forms of the letter look like.
- Attach the uppercase and lowercase card next to the corresponding mnemonic picture on the wall frieze.



How are the two letter shapes the same? How are they different?

Partner Practice

Reading Sounds

- Distribute the Partner Practice Booklets and a crayon or pencil to each student. Ask students to open their booklets to page 4. Encourage partners to help each other find the page. Have the partners work together to read the sounds.
 - Jelly will point to the sounds, and Peanut Butter will read them. Jelly will help as needed.
 - After Peanut Butter has finished reading the sounds, Jelly will write their initials in the box at the bottom of Peanut Butter's page.
 - Peanut Butter will point to the sounds, and Jelly will read them. Peanut Butter will help as needed.
 - After Jelly has finished reading, Peanut Butter will write their initials in the box at the bottom of Jelly's page.

Stretch and Read

- Explain that the sounds we have been learning can be put together to make words. Model the process by placing the letter cards for /v/, /e/, /s/, and /t/ a few spaces apart in a pocket chart or along a chalkboard tray. Gradually move the letters closer together, and have students blend the sounds together with you until you say “vest.” Repeat with the word “jam.”

We know that words are made of sounds. We can read a word by saying all the sounds and blending them together. We call this Stretch and Read.

Alphie and his friends can use Stretch and Read to sound out words too. Let's watch.



- Show the Sound and the Furry video segment.

Now you will get to use Stretch and Read to read some words with your partner. The words you will read are different from the words we read together. Let's see who can figure out the words!

- Have students work with their partners, using Stretch and Read, to read the words from their Partner Practice Booklets.
- Use the sharing sticks to select a student to read the sounds for the class. Select another student to read the words. Provide assistance as needed. Award pocket points if they attempt to read all the sounds or words.



Forming the Letter

Introduce the shape of /v/.

- Explain that now you will show students how to write the letter that makes the /v/ sound. Trace the letter with your finger as you say the letter-writing cue “Down one wing and up the other.” Ask students to say the cue with you two or three times as you trace the letter again.
- Show the letter-only side of the key card. Make a connection to the letter shape and the mnemonic picture.

Example:

- **What picture does this letter look like? *Vulture*. Yes, this letter looks like a vulture.**

Write /v/.

- Demonstrate writing the letter in front of students several times on a writing board or chart paper. Ask students to say the writing cue with you as you form the letter.
- Hold the picture side of the key card next to the letters you have written. Ask students whether your letters look like the vulture. Place the key card in a pocket chart with the letter side facing outward.
- Guide students to practice forming the letter shape using their fingers as pencils several times in different ways (in the air, on the carpet, on their legs, etc.) Encourage them to say the cue as they write the letter.
- Distribute individual whiteboards and dry-erase markers, chalkboards and chalk, or paper and pencils or crayons. You may also use the space provided in the Partner Practice Booklet for writing. Ask students to write /v/ several times, reciting the cue with them each time.
- Ask students to examine their partners' letters for /v/ and circle the best one. Encourage them to tell their partners why they think it's the best.
- Have students write other letters that they have learned. Encourage them to say the cue as they write each letter.
 - /j/ **Down Jane's back and up to her toes. Jump to the ball.**
 - /w/ **Wiggle down, wiggle up, down and up.**
- Include other review letters as needed by your students.

Stretch and Count/Stretch and Spell

- Call out a word, and ask students to break it down as they count the number of sounds in the word on their fingers. Ask them to draw a line for each sound that is represented in the word. Say the sounds in the word again, and have students write the letters that make the sound on the lines to spell the word.

vest

jam

- Collect the Partner Practice Booklets.

Emergent Reading**Story Review**

- Briefly review the concepts-of-print book *Fruit Salad*.
- Review the focus skills.

Point to the word “we” on the word wall. **Remember that we will see the word “we” from our wall word in the story.**

Write the word “cut” on the board. **We can sound out this word.** Have students stretch and read “cut.”

You will be able to read the rest of each sentence by looking at the pictures.

Partner Reading

- Distribute a book to each student.
- Have students read the story with their partners, alternating pages. When they finish, they should switch parts and read the story again.



Invite students to sing “March to Math” to signal that it is time for Math Mysteries.

Math Mysteries

TIMING GOAL: 25 minutes

Show What You Know



- Call up three students of different heights.

WGR: **Which student is the tallest?**



- Award pocket points if students are able to tell you which student is the tallest.
- Ask students to think about ordering students from tallest to shortest.

T-P-S: **How would you order these students from tallest to shortest?**

RWE: **I would find the tallest student and line that student up first. Then, I would find the next-tallest student by looking at the two students left and by deciding who is taller. This person would go next in the line, Then, I would put the final student in line. Then the students would be in order from tallest to shortest.**



Active Instruction

- Introduce the concept of measuring.

We can look at objects and tell which is the longest or shortest, but sometimes we need to know more. Sometimes we need to know how much longer or shorter something is. This is called measuring. Today we are going to learn to measure things.

- Display your Crayon Tape Measure.



T-P-S: **What can you tell me about this?** *It is a picture of several crayons. There are ten crayons in a line.*

- Ask students to count the crayons with you. Explain that you will use the Crayon Tape Measure to see how tall or long something is.

T-P-S: How could we use this Crayon Tape Measure? *We could hold the tape measure up to something and count to see how many crayons long it is.*

- Model using the tape measure to measure your foot.

I'm going to place the Crayon Tape Measure down beside my foot. I'm going to make sure that the end of the tape measure lines up with my heel. Then I can count the crayons to see how long my foot is. Count the number of crayons from your heel to the end of your big toe. **When we measure, we can say, "about," if the object we are measuring does not measure to the exact end of the unit. My foot is about four (or five) crayons long.**

- Ask students to estimate using the Crayon Tape Measure.

T-P-S: How long do you think your foot is?

Partner Practice

- Give each partnership a tape measure and each student a Body Measurement Sheet. Explain to students that they will share the tape measure and practice measuring the objects on the recording sheet.
- Remind them to check their partners' measurements and to be sure to line each object up with the end of the tape measure.
- Assist students as they measure to make sure that they are using the measuring tape appropriately and recording their results.

Recap



- Use the sharing sticks to select a few students to share how they measured the objects listed on the recording sheet. Award pocket points if several students are able to successfully explain how they measured the objects.
- Review the rules for measuring.



T-P-S: What do we need to remember when we measure with a measuring tape? *We need to remember to put the end of the measuring tape at the end of the object. We need to remember that we can say, "about," if the measurement is not exact.*

- Tell students that the Crayon Tape Measures will be in the math lab tomorrow.



Sing "It's time to go to sleep. It's time to count our sheep." Then count in a quiet voice, touch each student lightly on the head, and send them to retrieve their nap-time supplies.

Let's Daydream

TIMING GOAL: 25 minutes

Routine

1. Have students get out their supplies (towels, cots, etc.) for nap time.
2. Read the selected poetry, and play soft music (optional) as students rest.
3. Allow students to quietly look at another book during this time if they prefer.

Recommended Poetry Selection

- “The Gentle Cow,” *The 20th Century Children’s Poetry Treasury*, page 8

Introduce the Poem

Today’s poem is about one of the animals that gives us both protein and dairy foods. Listen to see what animal it is.



Gather students in a place where you will model during Write Away.

Write Away

TIMING GOAL: 20 minutes

Prewriting

- Present the writing topic for the day, and encourage students to share their ideas. To discourage copying later, do not write the ideas on the board.

Today we have been talking about dairy and protein. We know that we need dairy and protein for good nutrition. You are going to write about a kind of dairy or protein that you eat for dinner.



T-P-S: What kinds of dairy or protein foods do you eat for dinner?

- Share an example that applies to you.

I think that I will write a sentence that says, “I make chicken for dinner.”

- Review previously introduced emergent-writing strategies.



T-P-S: What are some things that I can do if I don’t know how to write some of the words in my sentence? Draw a picture, draw a line, write sounds that I know, copy a word, and remember a word.

I will use these things to write my sentence. You can use them when you write your sentence too.

- To model writing your sentence, use the writing strategies that have already been introduced.

First, count the words on your fingers as you say the sentence again. Then, draw lines on the board to represent each word.

Example:

I am ready to write my sentence. My sentence is, “I make chicken for dinner.”

- **The first word is “I.” “I” is on the word wall, so I will copy it.** Write “I” on the first line.
 - **The next word is “make.” I hear the /m/ and /k/ sounds in “make.”** Write “m” and “k.”
 - **“Chicken.” What sounds do you hear in “chicken”?** Say the word slowly, emphasizing the individual sounds. Write any letters that students say.
 - **“I make chicken for dinner.” The next word is “for.” I remember how to write “for.”** Write “for.”
 - **The last word is “dinner.” What sounds do you hear in “dinner”?** Say the word slowly, emphasizing the individual sounds. Write any letters that students say on the last line. **I also need to remember to put a period after this word because it is the end of the sentence.**
- Reread your sentence, touching each word, or word representation, as you do.

Partner Planning

- Ask students to share what they would like to write with their partners. Encourage them to use the Say-It-Back strategy to show their partners that they are listening.
- Monitor students, and listen to their discussions. Ask one or two students what their partners are planning to write.

Writing

- Distribute pencils and either writing journals or paper.
- Monitor students as they write. Encourage them to use the writing strategies that you have introduced as needed.
- Hold a writing conference with a few students as time permits. Record the stage of writing that you observe for these students on the weekly record form.

Sharing

- Ask students to share their sentences with their partners.
- Use the sharing sticks to select one or two students to share their writing with the class. Acknowledge and celebrate any emergent-writing strategies that they have used.



Invite students to recite or sing “Let’s Think About It” as they move to the gathering area.



Let's Think About It

TIMING GOAL: 20 minutes

Theme-Learning Recap



- Review the learning focus of the day.

We've talked about foods from the dairy and protein groups today. One of the groups is made up of foods made from milk. T-P-S: What do we call the group of foods that are made from milk? *Dairy*.

Foods that come from animals, such as meat, fish, and eggs, and also nuts and dry beans are all part of the protein group. Eggs and ham are two types of protein foods. T-P-S: Why do we need to eat protein and dairy products? *To grow strong and healthy, etc.*

- Invite students who visited the writing lab today to bring their plates to the front of the room. Identify any dairy or protein foods that were found.
- Review food names and food groups by playing Nutrition Lotto. Make sure that the groups get game cards that are from those they used on day 3.
- Show the USDA MyPlate poster. Review the food groups that students have learned about so far.



Let's look at our placemat again. WGR: How many sections of the plate have we talked about so far? *1, 2, 3, 4, 5; five*. Yes. We have talked about all five sections! WGR: Which sections are the largest? *Grains and vegetables*. WGR: Which section is the smallest? *Dairy*. The bigger the space, the more of that food we need to eat to be strong and healthy. Notice that the fruits and vegetables together take up half of the plate! When you look at your dinner plate, you should see many more fruits and vegetables than grains, such as bread, rice, or potatoes, or proteins such as meat.



Vocabulary Review

- Briefly review the new theme-related vocabulary words. Use My Turn, Your Turn to have students practice saying each word. Then provide a brief definition, and make connections to the contexts in which the words were used today.



One of our new words today is “dairy.” “Dairy” describes milk or food products that are made from milk. T-P-S: When did we see, hear, or use the word “dairy” today?

Our other new word today is “protein.” Protein products come from plants and animals. T-P-S: When did we see, hear, or use the word “protein” today?



- Ask partners to work together to think of a sentence that uses one of the words. Use the sharing sticks to select a student to share the sentence with the class. Use the Oral-Language Scoring Rubric to score the response. Record the score on the weekly record form.

| Oral-Language Scoring Rubric | |
|------------------------------|---------------------------------------------------------------------------------------|
| 70 | The student does not respond, or the response does not make sense. |
| 80 | The student responds with a word or phrase that makes sense. |
| 90 | The student responds in a complete sentence that makes sense. |
| 100 | The student responds in a complete sentence(s) that makes sense and includes details. |

- Use the suggestions below to help foster oral-language development.

Theme Vocabulary:

dairy
protein

| Fostering Richer Language | | |
|----------------------------------------------------------------------------------------------------|------------------------------------------------------------------------------------------------------------------------------------------|------------------------------------------------------------------------------------------------------------------------------------------------------------------------|
| Student Response | Teacher Prompt | Further Prompting |
| The student responds in an incomplete sentence. Milk dairy. | Good answer. Can you say that in a complete sentence? | If the student is unable to respond in a sentence, model a sentence for him or her. <i>We can say, Milk is a dairy product.</i> |
| The student responds in a complete, but not very elaborate, sentence. I eat dairy foods. | You made a complete sentence with the word. Can you add some details to your sentence? OR Can you tell us a little more about the _____? | If the student is unable to add details, prompt with a question about the sentence. Can you tell us more about the kinds of dairy foods you like to eat? |



- Award pocket points if the student is able to create a complete sentence.

Partner Challenge

- Review the Partner Challenge of the day.

We have one more opportunity to earn pocket points today! Let's review our Partner Challenge. Our Partner Challenge today is to show your partner all the Stop and Stay Cool steps that you can take when you are angry because someone broke your favorite toy. Allow time for students to practice the steps. Award pocket points when students demonstrate all the steps. You may want to recite the rhyme to help them remember the steps if they need support with this.



- Use the sharing sticks to select students to share their responses. If you feel your students are able, have them tell their partners' responses. Award pocket points when students successfully demonstrate the Stop and Stay Cool steps.
- Invite students to compliment the Cool Kid for successfully demonstrating Getting Along Together skills.

Pocket Points for the Day

- Empty the chips from KinderRoo's pouch, and encourage students to join you in counting them.
- Pour the chips into the jar, and observe how close the total is to the reward line.
- Remind students about their reward.

Home Link/Departure



- Invite students to tell their partners one thing that they did or learned today at school.
- Make any announcements or give reminders (upcoming field trips, picture day, etc.).
- Remind students to watch tonight's Home Link show. Tell students to click on the leopard for today's show.
- Read & Respond: **Share a book with someone in your family. Ask him or her to sign your Read & Respond bookmark.**
- Use the leopard stamp to place an animal image on each student's hand.

Day 5 | Ready, Set...

Focus

Eating too many fats, oils, and sweets is unhealthy.

| Additional Materials Needed Today | |
|--------------------------------------------|-------------------------------------------------------------------------------------------------------------------------------------------------------------------------------------------------------------------------------------------------------------------------------------------------------|
| Greetings, Readings, & Writings | <ul style="list-style-type: none"> Literacy Lab: Key card for “v” |
| Gathering Circle | <ul style="list-style-type: none"> KinderCorner 2nd Edition Plus Media and Software flash drive Stop and Stay Cool Steps poster or IWB access |
| Theme Exploration | <ul style="list-style-type: none"> Nutrition Lotto, dramatic play, or real fats, oils, and sweets products placed in a grocery bag USDA MyPlate poster KinderRoo Theme vocabulary word card for “unhealthy” or IWB access |
| Rhyme Time | <ul style="list-style-type: none"> KinderCorner 2nd Edition Plus Media and Software flash drive |
| STaR | <ul style="list-style-type: none"> A storybook to read for free-choice day |
| 15-Minute Math | <ul style="list-style-type: none"> Red and green markers, one of each |
| Snack/Outside/ Gross-Motor Play | <ul style="list-style-type: none"> A variety of foods from among the groups in the USDA MyPlate graphic (except the fats, oils, and sweets group) (optional) |
| Stepping Stones | <ul style="list-style-type: none"> KinderCorner 2nd Edition Plus Media and Software flash drive Picture cards for /ch/, /j/, and /v/ Partner Practice Booklets for unit 6 A concepts-of-print book to read for free-choice day |
| Math Mysteries | <ul style="list-style-type: none"> Crayon Tape Measure from Math Mysteries on day 4 Let's Measure Sheet (appendix), one per student Plastic bags, each with thirty to forty linking cubes, one bag per partnership Books Backpacks Blocks |
| Let's Daydream | <ul style="list-style-type: none"> “A Good Place to Sleep,” <i>The 20th Century Children's Poetry Treasury</i>, page 84 |
| Write Away | <ul style="list-style-type: none"> No new materials |

Additional Materials Needed Today

Let's Think About It

- Nutrition Lotto game cards placed in a grocery bag
- Cool Kid certificates

Learning Labs—Additional Materials

- SOLO assessment for your current grading period (see *KinderCorner 2nd Edition Plus Teacher's Manual*)

Math Lab | How Big Is It?

- Crayon Tape Measure from day 4 Math Mysteries
- Wonder Box

Day 5

Greetings, Readings,
& Writings

TIMING GOAL: 15 minutes

| Student Routines | Teacher Routines |
|-------------------------------------------------------------------------------------------------------------------------------------------------------------------------|----------------------------------------------------------------------------------------------------------------------------------------------------------------------------------------------------------------------------------------------------------------------------------------------------------------------------------------------------------------------------------------------------------------------------------------------------------|
| <ol style="list-style-type: none"> 1. Remove coats and backpacks. 2. Turn in homework. 3. Sign in. 4. Self-select activities. | <ol style="list-style-type: none"> 1. Greet parents and students. 2. Remind students to read the Arrival Activities poster as they prepare for their day. 3. Encourage students to describe what they are doing in full sentences as you observe their activities. 4. Observe for student progress with their individualized objectives from the weekly record form. Circle demonstrated skills if applicable. |

Homework

- Read & Respond

Available Activities

Classroom Library Lab

- Same as day 4

Literacy Lab

- Add the key card for “v” to the lab. Encourage students to use the tactile letter-formation materials to practice forming the shape of /v/.

Math Lab

- Same as day 4

Computer/Media Lab

- Same as day 4

Writing Lab

- Same as day 4

Other

- If you have any theme-related puzzles or games, make them available.



Sing a transitional gathering song. Encourage students to sing along as they move to the gathering area.

Gathering Circle

TIMING GOAL: 15 minutes

Routine

1. Welcome students to the Gathering Circle.
2. Check attendance.
3. Discuss yesterday's homework assignment. Award pocket points if at least half the students completed their homework.
4. Remind students about the responsibilities associated with each classroom job as needed.
5. Make sure that students are sitting with their partners for the week.

Home Link Debrief



- Invite children to share what they remember from last night's Home Link show.
 T-P-S: **In last night's story, how do the children make butter?**
- Use the sharing sticks to select two or three children to share their responses with the whole class. Award pocket points in recognition of thoughtful answers.

Class Council



- Use the rhyme and poster to review Stop and Stay Cool. Then show the "Stop and Stay Cool (excerpt)" video.
- Use the Getting Along Together skills previously introduced to address any classroom concerns. If there are no classroom concerns that you need to resolve, use the following scenario to reinforce using the Stop and Stay Cool strategy.
- Have students act out how to stop and stay cool in the following situation. **You and your friend are playing a video game. Your friend keeps winning, and you don't get a chance to play. You ask him for a turn, and he says, "No, I get to play as long as I want!" You have to sit and watch him keep playing. You ask again, and he says, in a mean voice, "Too bad, you just have to wait." You get so angry with your friend that you could mark a Feelings Thermometer at the five. T-P-S: What can you do? Show how you would use the steps of Stop and Stay Cool to get yourself in control.** Refer to the Stop and Stay Cool Steps poster, or recite the rhyme from day 3, if necessary, to help students remember the process.



Theme Exploration

TIMING GOAL: 15 minutes

Partnership Question of the Day



T-P-S: What do you think “unhealthy” means?

This week we have been learning about healthy foods. Today’s Daily Message will tell us about some foods that can be unhealthy when you eat too much of them.

Daily Message

Eating too many fats, sweets, and oils is unhealthy.

- Write the Daily Message in front of students, reading each word as you finish writing it. Then read the entire message again, touching each word as you read it.
- Reinforce literacy objectives by pointing out the following:
 - WGR: **How many sentences do we have in our Daily Message?** *One.*
How do you know? *There is only one period.*
 - Reread the sentence, prompting students to identify words beginning with the sound /f/.
 - Use Stretch and Read to have students read the word “fats.”



Theme Learning

- Explain the content of the Daily Message.

So far this week, we’ve talked about all kinds of healthy foods.
T-P-S: **Tell your partner the name of one healthy food that we’ve talked about this week.**

Today KinderRoo is going to show us some unhealthy foods. A few minutes ago, I asked you what you think “unhealthy” means. I heard some good ideas. If something is unhealthy, it isn’t good for you. Most people eat unhealthy things sometimes, but when we eat too much of them or eat them too often, we don’t grow strong and healthy.
- Bring out KinderRoo next to her grocery bag filled with foods that are high in fat, oil, or sugar.

Let’s take a look at some of the unhealthy foods that KinderRoo brought today.
- Have students take turns selecting and presenting an item for the rest of the class to see. Have students name each item that is presented. If an item is unfamiliar to students, name the item, and have students repeat the name after you. Students should hold onto their food items.

These foods are not very healthy because they contain lots of fat, oil, or sugar. Our bodies only need a little bit of fat, oil, and sugar. Too much of these things is not good for our bodies.



- Place the USDA MyPlate poster on the floor.

This week we have seen where grains, fruits, vegetables, dairy, and protein foods belong. Look at the plate and cup. T-P-S: Where do you think these unhealthy foods belong? RWE: There is no section for these foods because we do not need to eat them every day. For good nutrition, we should eat foods from the grains, fruits, vegetables, protein, and dairy sections every day. Foods that are high in fat, oil, and sugar are okay sometimes, but not every day. When we do eat unhealthy foods, we only need a little bit—not a lot. You might eat a slice or two of pizza, but you wouldn't eat an entire pizza by yourself!

- Collect the food items from students.
- Play the digital dictionary video for “unhealthy.”
- Re-emphasize the theme-related vocabulary word. Post the word, or point to it on the interactive whiteboard, as you discuss it.



Our new word for today is “unhealthy.”

Foods with a lot of sugar, such as cookies, or a lot of fat, such as bacon, are not very healthy. It is fine to eat these foods sometimes, but eating too much of them or eating them often is unhealthy. I can make a sentence with the word “unhealthy.”

Drinking too many sugary drinks, such as soda, is unhealthy.



Ask students to stand up as they sing “It’s Time for a Rhyme” to signal the transition to Rhyme Time.

Rhyme Time

TIMING GOAL: 10 minutes

Say the Rhyme

- Have students recite “A Healthy Treat.” Encourage them to do the physical motions that accompany the rhyme.
- Read the words (see day 1), or play the video.



Develop Phonological Awareness—Blending Onsets and Rimes of Single-Syllable Spoken Words



- Introduce the activity to students by reviewing some of the foods in “A Healthy Treat.”

We hear about many different kinds of food when we recite “A Healthy Treat.” T-P-S: What are some of the foods that are named in the rhyme?

- Explain the game to students, demonstrating an example.

We are going to pretend to plan a picnic with some of the food from the rhyme. I have a list of foods to pack for our picnic, but it is in a secret language. I need your help to crack the code.

The foods on my list are missing some sounds. Each food name is missing its beginning sound. When I look at the list, I see “ilk.” “Ilk”...what could that mean? “Milk!” “Ilk” is “milk” with the “m” left off. /M/...ilk.

Help me figure out the names of the other food items so we can be sure to pack them for our picnic.

- Play the game with food words from the rhyme or with other food names that students are familiar with. Some examples follow:
 - ice (rice)
 - eat (meat)
 - ead (bread)
 - ish (fish)
 - each (peach)
 - ake (cake)

- If students appear to be struggling, provide the onset. Then prompt students to blend the onset and rime.



- Award pocket points if several students are able to successfully identify the missing onset and blend the complete word.



Sing the song “Let’s Read Together” with students.



TIMING GOAL: 20 minutes



- Reread a favorite STaR book or another book that you would like to share.
- Use Think-Pair-Share to have students share their favorite parts of the book.
- See the Resource Corner in the appendix for other great stories that support this theme. You may already have some of them in your classroom, school, or public library.



Use the 1-2-3 Move signal to move students from the STaR area to the dramatic play lab for the beginning of the lab tour.



TIMING GOAL: 40 minutes

Routine

1. Have a lab tour to explain the activities or materials in any new labs.
2. Guide students as they select the lab that they will visit. Use the lab-management system to ensure that not too many students plan to visit the same lab at the same time.
3. Students will complete their Learning Lab plan. Conference with as many students as possible about their writing before they are dismissed to labs.
 - Write the code for the writing stage exhibited by the student in the top right-hand corner of the student's paper.
 - Use the methods described in the *Writing Development Feedback Guide* to provide feedback.
4. Administer the SOLO to a few students while the rest of the class is engaged in lab activities. Record the SOLO scores in the space provided on the weekly record form.

Dramatic Play Lab | KinderCorner Cafe

Description:

- The dramatic play lab will be a cafe.

When You Tour:

- Remind students that the dramatic play lab will be a cafe. Ask students what kinds of dishes that don't have a lot of fat they can serve in the cafe.

Blocks Lab | Food Delivery

Description:

- Students will use the trucks to transport food to the KinderCorner Cafe.

When You Tour:

- Remind students that they can use the trucks to transport food to the KinderCorner Cafe.

Art Lab | Still Life

Description:

- Students will continue to create still life paintings of fruit.

When You Tour:

- Remind students that they can paint pictures of the fruit.

Classroom Library Lab | What's Cooking?

Description:

- Students will continue to explore books independently or with a friend. Theme-related books will be added to the regular classroom library.

When You Tour:

- Remind students that they can find cookbooks in the classroom library lab. Encourage students to look for recipes that are low in fat.

Literacy Lab | Play School: Letter Sounds Soup

Description:

- Students will continue to have the opportunity to play a game in which they make pretend soup and practice the sounds for letters they have learned.

When You Tour:

- Remind students how to play the game. Let them know that they may also play school instead if they prefer.

Math Lab | How Big Is It?

Description:

- Students will measure various objects using the Crayon Tape Measure.

Purpose:

- This lab provides students with an opportunity to practice measuring with nonstandard units of measurement.

When You Tour:

- Point out that the Crayon Tape Measures from yesterday's Math Mysteries are now in the math lab. Tell students that they will pretend that they are artists who need to measure their sculptures and paintings to figure out how big each is to display them in their art gallery. They will use the Crayon Tape Measure to help them figure this out.

Facilitate Learning:

- Ask students to explain how they measured the objects that they selected. Encourage them to pretend that the various objects are artwork, using items from the Wonder Box as needed. Jump in, and join the play as you interact with students.

Examples:

- **This is a very nice painting. I think I would like to buy it, but I need to know how big it is to tell if it will fit on the wall in my living room. Can you measure it for me?**
- **These two sculptures are very interesting. They look like they might be the same size. Can you measure them for me and tell me how big each one is?**

Computer/Media Lab | Free Exploration

Description:

- Students will continue to explore educational software or listen to music with computers, CD players, or other digital devices.

When You Tour:

- Remind students that they can explore educational software or listen to music.

Sand/Water Lab | Harvesting Vegetables

Description:

- Students will continue to dig up vegetables that the teacher has hidden in the sand.

When You Tour:

- Remind students that they can dig up vegetables that the teacher has hidden in the sand. Ask students if vegetables are high in fat or low in fat.

Science Lab | Scientist's Station: Seed Study

Description:

- Students will continue to use examination tools to investigate seeds from fruits.

When You Tour:

- Explain that students can examine, describe, and record information about seeds.

Writing Lab | Healthy Helpings

Description:

- Students will continue to write, draw pictures, or glue pictures of a variety of foods on to paper plates.

When You Tour:

- Remind students that they can create their own food plates by drawing pictures of food or cutting out food pictures and gluing them on to the plates. Ask students which low-fat dishes they can put on their plates.



Provide five-minute and three-minute warnings before the end of the labs. Then sing the clean-up song to prompt students to put away the lab items and move to the 15-Minute Math board.



15-Minute Math

TIMING GOAL: 15 minutes

Complete the following activities as described on day 1.

Calendar

Days of the Week

Days of School Tape

- If today is the fiftieth day of school, use a green marker to record the number, and then circle the number 50 using a red marker. Ask students what they notice about the Days of School Tape. *The number 50 is written in green instead of black, and it has a red circle around it. Say, **I wrote 50 in green and circled it in red because it ends in 0. We can skip count by 5s by reading the numbers that have been written in green.** Point to the green numbers on the number line as you say, **5, 10, 15, 20, 25, 30, 35, 40, 45, 50.** Then say, **We can skip count by 10s by reading the numbers that have been circled in red.** Point to the numbers that have been circled in red as you say, **10, 20, 30, 40, 50.***

Ten-Frames

Hundreds Chart

- Ask students to determine which number you will color today. After you color it, invite them to read the numbers in the colored boxes with you. If today is the fiftieth day of school, ask, **How many rows have we colored in on the Hundreds Chart? Five. How many rows do we still need to color before we can celebrate our 100th day of school? Five. How do you know? I counted the rows that are not colored. Each row has ten squares, so I can skip count by 10s to find out how many days until our 100th day of school.** Point to each uncolored row as you count, **10, 20, 30, 40, 50. We have fifty days until we celebrate our 100th day of school. We are halfway there!**

Shorter Than/Longer Than a Foot

- Point to the poster, and read the names of the objects listed on the Shorter Than a Foot side. Ask, **What do you notice about the objects on this side?** Read the names of the objects on the Longer Than a Foot side, and ask students what they notice about the objects on that side of the poster. Select a student to use a foot cutout to find an object that is shorter than the foot cutout. Select another student to use a foot cutout to find an object that is longer than the foot cutout. Have the two students compare their objects. Then record the names of the objects on the poster.



Recite the Stop and Stay Cool rhyme as students move to the area where you will serve the snack.

Snack • Outside • Gross-Motor Play

TIMING GOAL: 30 minutes

Snack

- Offer a wide variety of healthy foods from the USDA MyPlate graphic (except fats, oils, and sweets) that you focused on last week. Allow students to choose a small amount from each group of foods. Talk with students about why these foods are good choices for them and about how they help them grow. Expand on the concept of the different kinds of foods available in markets and how all the snacks came from just one supermarket.

Outside/Gross-Motor Play

- For students who are interested in a structured activity, play the exercise game To Market, To Market. Establish a starting (to market) and a finishing (home again) line several feet apart from each other. Have students stand behind the starting line and walk (jog, skip, hop, etc.) toward the finishing line as you chant, “To market, to market, to buy a fat pig” (“fat hog,” “plum bun”). When you chant, “Home again, home again...,” have students return, moving back toward the starting line.



When students come back inside, select one student to play teacher. As students return to the gathering area for Stepping Stones, that student will point to each word on the word wall for the other students to read.

Stepping Stones

TIMING GOAL: 30 minutes

Beginning Phonics: Review /ch/, /j/, and /v/

Remember the Review Sounds



- Explain that today students will review the last three new sounds that they have learned.
- Show the Animated Alphabet segments for /ch/, /j/, and /v/.

Review Games

Letter Detectives

- Display the key cards for the three review letters. Have partnerships search the classroom for either objects that begin with one of the review sounds or a word that contains one of the letters. Students should stand next to the object or word that they have found. Ask each partnership to share their object or word with the class.
- Award pocket points if most students successfully find objects or words that represent the review sounds.



Body Formation

- Invite students to form the shape of each of the review letters with their bodies.

Matching Game

- Display the key cards for the three review letters a few spaces apart. Show a picture that begins with one of the review sounds. Provide a moment for students to think and then point to the key card that corresponds to the correct beginning sound.

Picture Cards:

cherry
chain
jacket
jam
vegetables
van

Partner Practice

- Ask students to find page 6 in their Partner Practice Booklets.
- Announce which partner should begin, and have students take turns reading the sounds to each another. The listening partners should point to the sounds and provide help as needed. They should write their initials in the box at the bottom of the page once the reading partners have completed the page.
- When partners have finished, have the class read the sounds together. Then use the sharing sticks to select a partnership to read the sounds to the class.
- Invite partners to take turns reading the words. When partners have finished, have the class read the words together. Then use the sharing sticks to select a partnership to read the words to the class.
- Award pocket points if students successfully read the sounds and words.



Writing

- Distribute writing supplies (mini whiteboards and dry-erase pens, chalkboards and chalk, crayons and paper, etc.) to each student.
- Have students write letters for sounds as you call them out, reinforcing the writing cues as needed. Include the sounds that have been introduced this week and those for which students have not yet demonstrated mastery as recorded on the weekly record form.
 - /c/ **Curl left around the caterpillar.**
 - /h/ **From head to toe and over his back.**
 - /j/ **Down Jane's back and up to her toes. Jump to the ball.**
 - /v/ **Down one wing and up the other.**

Emergent Reading

Free Choice

- Invite students to select one or more concepts-of-print books to read with their partners.
- Monitor students as they read together. When student demonstrate skills, record these observations on the weekly record form.



Invite students to sing “March to Math” to signal that it is time for Math Mysteries.

Math Mysteries

TIMING GOAL: 25 minutes

Show What You Know

- Hold up a book. Show students the Crayon Tape Measure from day 4’s Math Mysteries lesson. Ask students to estimate how long the book is.

T-P-S: I want you to estimate, or guess, how long you think this book is if I were to measure it with the Crayon Tape Measure.
- Award pocket points if students have reasonable estimates.
- Select a student to come up and measure the book using the Crayon Tape Measure. Ask students to count with you as you measure. Have students think about their estimates and whether they were close to the actual measurement.
- Reflect on important steps when measuring.



T-P-S: Why is it important to start your tape measure at the edge of the object that you are measuring?



RWE: It is important to start your tape measure at the edge of the object that you are measuring because if you were to start the tape measure in the middle, your measurement would be wrong.

Active Instruction



- Ask students to think about other ways to measure.

T-P-S: What are some other things that we could use to measure besides our Crayon Tape Measures? We could use beads, cubes, pencils, etc. to measure.

- Model using cubes to measure the book that you measured earlier.

This book measured five crayons long when we used our Crayon Tape Measure. I wonder how many cubes long it is.

- Have students estimate how many cubes long they think the book is.
- Place cubes along the length of the book. Make sure that the cubes are side by side without gaps and that the first cube lines up at the top of the book. Do not connect the cubes.



WGR: How many cubes long is the book?

- Hold up the Let's Measure Sheet, and show students how to record the measurement. Remind students that if something does not measure exactly, they can say it is "about ___ cubes long."

Partner Practice

- Explain the activity to students.

Today you and your partner will work together to measure the length of a book, a backpack, the edge of a desk, and a block. Take turns measuring the objects, making sure that your partner is lining up the cubes at the edge of each object and that there are no gaps between the cubes. When you both agree on a measurement, you will then record your measurements on your Let's Measure Sheet.

- Distribute a Let's Measure Sheet to each student. Then distribute a plastic bag of linking cubes to each partnership. Monitor and assist students as they measure the objects and record the measurements. Note students who are able to measure using nonstandard units.



You might like to group the different objects and place them in several locations around the room so students will not waste time looking for the objects or run from place to place to take the objects' measurements.

Recap

- Use the sharing sticks to select a few students to share how they measured the objects listed on the recording sheet. Award pocket points if several students are able to successfully explain how they measured the objects.
- Review the longest and shortest measurements from the activity.

T-P-S: Which object had the longest measurement? How do you know? Which object was the shortest? How do you know?

- Tell students that they can measure objects using cubes in the math lab the next time they come to school.



TRANSITION

Sing "It's time to go to sleep. It's time to count our sheep." Then count in a quiet voice, touch each student lightly on the head, and send them to retrieve their nap-time supplies.



Let's Daydream

TIMING GOAL: 25 minutes

Routine

1. Have students get out their supplies (towels, cots, etc.) for nap time.
2. Read the selected poetry, and play soft music (optional) as students rest.
3. Allow students to quietly look at another book during this time if they prefer.

Recommended Poetry Selection

- “A Good Place to Sleep,” *The 20th Century Children’s Poetry Treasury*, page 84

Introduce the Poem

Today I’d like to read you a poem called “A Good Place to Sleep.” The author’s words are gentle like the words and rhythm of a lullaby. They give you a quiet feeling. Listen. Then close your eyes, and think about your favorite place to sleep.



Gather students in a place where you will model during Write Away.



Write Away

TIMING GOAL: 20 minutes

Prewriting

- Present the writing activity for the day.

Today instead of writing a new sentence, we will add a sentence to one that we wrote earlier this week. First, you will choose the sentence that you would like to add to. Then, you will tell us more about something you wrote about.

- Share an example that applies to you. Review the four sentences that you wrote this week, and select one to elaborate on.

I think I will choose this sentence. Read the selected sentence. **Now I will tell more about my sentence.** Share a new sentence that expands on the information provided in your first sentence.

- Model writing your second sentence using the strategies from the Writing Strategies Bank.
- Reread your new sentence, touching each word, or word representation, as you do.

Partner Planning

- Ask students to share what they would like to write with their partners. Encourage them to use the Say-It-Back strategy to show their partners that they are listening.
- Monitor students, and listen to their discussions. Ask one or two students what their partners are planning to write.

Writing

- Distribute pencils and either writing journals or paper.
- Monitor students as they write. Encourage them to use the writing strategies that you have introduced as needed.
- Hold a writing conference with a few students as time permits. Record the stage of writing that you observe for some students on the weekly record form.

Sharing

- Ask students to share their sentences with their partners.
- Use the sharing sticks to select one or two students to share their writing with the class. Acknowledge and celebrate any emergent-writing strategies that they have used.



Invite students to recite or sing “Let’s Think About It” as they move to the gathering area.

Let's Think About It

TIMING GOAL: 20 minutes

Theme-Learning Recap



- Review the learning focus of the day.

Today we learned that some foods are unhealthy for us. Foods with a lot of fat, oil, or sugar can be tasty, but eating too many of them is not good for us. We should only eat foods like this sometimes, not every day. T-P-S: What are some foods that we should only eat a little of every once in a while? Answers will vary.

- Use the USDA MyPlate poster to review the learning focus of the week. As you review, incorporate the theme-related vocabulary words into your discussion.

This week we have been learning about the foods we need to eat to help our bodies stay healthy and grow strong. Food is sorted into five main groups: grains, fruits, vegetables, protein, and dairy. Our plate and cup show us how much of these foods we should eat each day. When we eat good, balanced meals, we practice good nutrition. Healthy food gives our bodies energy so we can run and play. Eating too many unhealthy foods hurts our bodies.

- Tell students you will review good nutrition by playing a game. Bring out KinderRoo and the bag of Nutrition Lotto game pieces. Explain to students that KinderRoo is about to prepare dinner for her family and she wants to include healthy foods. You will draw a card from the bag. If the card depicts a healthy food, then students should stand. If the food is unhealthy, or a treat, students should sit down. Draw cards as time allows until you deplete the bag.



Vocabulary Review

- Briefly review the new theme-related vocabulary word. Use My Turn, Your Turn to have students practice saying the word. Then provide a brief definition, and make connections to the contexts in which the word was used today.



Our new word today is “unhealthy.” We use the word “unhealthy” to describe foods that are not good for us. T-P-S: When did we see, hear, or use the word “unhealthy” today?



- Ask partners to work together to think of a sentence that uses the word. Use the sharing sticks to select a student to share the sentence with the class. Use the Oral-Language Scoring Rubric to score the response. Record the score on the weekly record form.

| Oral-Language Scoring Rubric | |
|------------------------------|---------------------------------------------------------------------------------------|
| 70 | The student does not respond, or the response does not make sense. |
| 80 | The student responds with a word or phrase that makes sense. |
| 90 | The student responds in a complete sentence that makes sense. |
| 100 | The student responds in a complete sentence(s) that makes sense and includes details. |

- Use the suggestions below to help foster oral-language development.

Theme Vocabulary:
unhealthy

| Fostering Richer Language | | |
|-----------------------------------------------------------------------------------------------------------|------------------------------------------------------------------------------------------------------------------------------------------|---------------------------------------------------------------------------------------------------------------------------------------------------------------|
| Student Response | Teacher Prompt | Further Prompting |
| The student responds in an incomplete sentence. A lot of cookies unhealthy. | Good answer. Can you say that in a complete sentence? | If the student is unable to respond in a sentence, model a sentence for him or her. <i>We can say, Eating a lot of cookies is unhealthy.</i> |
| The student responds in a complete, but not very elaborate, sentence. Some foods are unhealthy. | You made a complete sentence with the word. Can you add some details to your sentence? OR Can you tell us a little more about the _____? | If the student is unable to add details, prompt with a question about the sentence. Can you tell us more about the foods that are unhealthy for us? |



- Award pocket points if the student is able to create a complete sentence.

Cool Kids Recognition

- Award certificates to the two students who served as Cool Kids this week and successfully demonstrated the Getting Along Together skills.

Pocket Points for the Day

- Empty the chips from KinderRoo's pouch, and encourage students to join you in counting them.
- Pour the chips into the jar, and observe how close the total is to the reward line.
- Remind students about their reward.

Home Link/Departure

- Invite students to tell their partners one thing that they did or learned today at school.
- Make any announcements or give reminders (upcoming field trips, picture day, etc.).
- Explain the homework assignment.

Theme Exploration: **Think about the food choices you are making. Try to eat more healthy foods than unhealthy foods so you can continue to grow strong and healthy!**

Read & Respond: **Share a book with someone in your family. Ask him or her to sign your Read & Respond bookmark.**

Day 6 | Ready, Set...

Focus

Food is sold at markets.

| Additional Materials Needed Today | |
|--------------------------------------------|-----------------------------------------------------------------------------------------------------------------------------------------------------------------------------------------------------------------------------------------------------------------------------------------|
| Greetings, Readings, & Writings | <ul style="list-style-type: none"> Weekly record form for unit 6—week 2 |
| Gathering Circle | <ul style="list-style-type: none"> No new materials |
| Theme Exploration | <ul style="list-style-type: none"> KinderCorner 2nd Edition Plus Media and Software flash drive Theme vocabulary word cards for “aisle” and “checkout” or IWB access |
| Rhyme Time | <ul style="list-style-type: none"> KinderCorner 2nd Edition Plus Media and Software flash drive Pictures of food or real food items Grocery bag or box |
| STaR | <ul style="list-style-type: none"> Trade book: <i>Bunny Cakes</i> |
| 15-Minute Math | <ul style="list-style-type: none"> No new materials |
| Snack/Outside/ Gross-Motor Play | <ul style="list-style-type: none"> A variety of foods from among the basic food groups (except fats, oils, and sweets) (optional) |
| Stepping Stones | <ul style="list-style-type: none"> Concepts-of-print book (teacher and student copies): <i>At the Market</i> Word-wall word card for “you” <i>At the Market</i> word-and-picture matching cards (appendix) |
| Math Mysteries | <ul style="list-style-type: none"> Premade tape circles on the floor or yarn Circle Workmat (appendix), one per student Ten-Frame Cards 1–10, one set per partnership Small plastic bags, each with twelve linking cubes, one bag per student |
| Let's Daydream | <ul style="list-style-type: none"> “The Noise of Nothing,” <i>The 20th Century Children's Poetry Treasury</i>, page 14 |
| Write Away | <ul style="list-style-type: none"> No new materials |
| Let's Think About It | <ul style="list-style-type: none"> Chart paper Marker Home Link animal hand stamp: lion |

Learning Labs—Additional Materials

Dramatic Play Lab | KinderCorner Market

- Play cash register
- Coupons
- Empty food containers
- Newspaper advertisements for grocery stores
- Paper bags (some painted in art lab) or canvas bags
- Play money
- Shopping cart(s) (toy)
- Plastic foods or foods created by students
- Boxes
- Construction paper
- Scissors
- Tape
- Markers or crayons

Teacher's Note: Some props, such as the cash register or play money, can be created by students.

Blocks Lab | Off to the Market

- Boxes, a variety, for packing groceries and loading onto trucks
- Trucks
- Plastic fruits and vegetables or those created by students

Art Lab | Shopping Bags

- Brown paper grocery bags or canvas bags
- Paintbrushes
- Paper
- Tempera paint in a variety of colors
- Fabric paint (optional)
- Vegetables and fruits for making prints (apples, green peppers, celery, oranges, etc., sliced so each one's distinctive shape is apparent) (optional)

Classroom Library Lab | Free Reading

- Theme-related books and other reading materials

Literacy Lab | Play School

- A chalkboard and chalk, whiteboard and marker, or chart paper and a marker for the student teacher; books, letter cards, magnetic letters, paper and pencils, letter stamps and ink pads, or any other items that students could use to play school

Math Lab | The Right Price

- Pencils, crayons, or markers
- Sticky labels or construction paper
- Guide sheet with several prices written on it (e.g., \$10.00, \$8.50, \$7.99)
- Grocery-store circulars

Computer/Media Lab | Free Exploration

- Computers, tape recorders, digital tablets, or other electronic media that you may have; software, applications, or CDs to accompany the media

Sand/Water Lab | Free Exploration

- Sand and water play tools—measuring cups and spoons, funnels, buckets, scoops, and plastic jars and bottles in a variety of shapes and sizes

Science Lab | Nutrition Lotto

- Nutrition Lotto game pieces in an opaque bag
- Nutrition Lotto boards

Writing Lab | Make a List, Please

- Variety of writing instruments (pens, pencils, crayons, markers) and things to write on (various types of lined and unlined paper, drawing paper, mini chalkboards or whiteboards, journals, etc.)

Day 6

Greetings, Readings,
& Writings

TIMING GOAL: 15 minutes

| Student Routines | Teacher Routines |
|-------------------------------------------------------------------------------------------------------------------------------------------------------------------------|----------------------------------------------------------------------------------------------------------------------------------------------------------------------------------------------------------------------------------------------------------------------------------------------------------------------------------------------------------------------------------------------------------------------------------------------------------|
| <ol style="list-style-type: none"> 1. Remove coats and backpacks. 2. Turn in homework. 3. Sign in. 4. Self-select activities. | <ol style="list-style-type: none"> 1. Greet parents and students. 2. Remind students to read the Arrival Activities poster as they prepare for their day. 3. Encourage students to describe what they are doing in full sentences as you observe their activities. 4. Observe for student progress with their individualized objectives from the weekly record form. Circle demonstrated skills if applicable. |

Homework

- Read & Respond

Available Activities

Classroom Library Lab

- Same as day 5

Literacy Lab

- Same as day 5

Math Lab

- Same as day 5

Computer/Media Lab

- Same as day 5

Writing Lab

- Same as day 5

Other

- If you have any theme-related puzzles or games, make them available.

Observe Student Progress

- As you interact with students, ask several of them the following questions to measure their skill development as identified on the weekly record form. Document any demonstration of the skills on the form.

Graphemes

- This week you will check to see whether each student can produce the sounds and write the shapes for the letters “sh,” “z,” and “w.” As students work together in their Stepping Stones Partner Practice Booklets, you will have many opportunities to collect this information.

Beginning Reading

- This week find out if your students can sound out the word “jam.” You may observe students as they read the word in their Stepping Stones Partner Practice Booklets on day 5, or ask them to read the word at another time during the week.

Emergent Writing

- When you conference with a student about his or her writing during Learning Labs planning or a Write Away lesson, record the code for the highest stage that he or she exhibits (before coaching) on the weekly record form.
 - **D** – Drawing
 - **S** – Linear Scribble
 - **LL** – Letterlike Shapes
 - **RL** – Random Letters
 - **AS1** – Initial Attempts at Approximated Spelling
 - **AS2** – Early Approximated Spelling
 - **AS3** – Intermediate Approximated Spelling
 - **AS4** – Advanced Approximated Spelling
 - **CS** – Conventional Spelling

Getting Along Together

- Observe students during Gathering Circle, snack time, and Partner Challenge activities this week to see whether each student can name the Stop and Stay Cool steps. You may also ask individuals, **What are the Stop and Stay Cool steps that you can use if you feel so angry that you are going to lose control?** Students must name all the steps (Recognize that you are angry, stop, give yourself a chilly hug, and breathe in and out.), although they may use different words to describe the steps, to demonstrate mastery of this skill.

Math

- Arrange bear counters into random sets of eight, nine, and ten. Ask students to identify which group of objects is a set of nine and which is a group of ten. During Math Mysteries, there are also many opportunities to ascertain whether students can identify sets of nine and ten.

- Continue to ask these questions of different students each day during Greetings, Readings, & Writings, Learning Labs, or other available times. Try to collect information about each skill for every student this week.



Sing a transitional gathering song. Encourage students to sing along as they move to the gathering area.

Gathering Circle

TIMING GOAL: 15 minutes

Routine

1. Welcome students to the Gathering Circle.
2. Check attendance.
3. Discuss yesterday's homework assignment. Award pocket points if at least half the students completed their homework.
4. Assign classroom jobs for the week.
5. Assign partnerships for the week. Have students move to sit with their partners.
6. Select this week's first Cool Kid.

Partner Challenge



Last week we learned about a way to help us calm down when we feel like we're losing control. WGR: What can we do when we want to calm down? *Stop and stay cool.*

We use the steps to stop and stay cool that Chilly taught us. These are important steps to remember when we feel like we are getting very upset. It's important to practice them so we can remember what to do. Today our Partner Challenge is to practice the steps of Stop and Stay Cool with your partner. You and your partner can take turns. One of you can show the steps while the other says the rhyme or uses the poster to help your partner remember the steps if he or she needs help. Point to the Stop and Stay Cool Steps poster, and remind students that they may use this for reference as they practice with their partners.

Let's practice now. Have one partner practice as the other observes and helps as needed. Tell students they will have time at snack (and other times) to practice more.

- Tell students they can earn pocket points when they show all the steps for Stop and Stay Cool.

Brain Game

- Introduce this week's Brain Game.

We play Brain Games to help us exercise our mind muscles. Our game this week is Going to the Market. This game helps us remember.

Demonstrate the Remember Signal (Massage your temples with your fingers.).

Invite the Cool Kid and another student to help you model how to play the game. Start the game by saying, **I am going to the market, and I will buy** (Name a food.). Have the Cool Kid repeat the sentence "I am going to the market, and I will buy (the item you named) and a (Name another item.). Have the other student repeat the sentence, including the items that you and the Cool Kid named and adding another item. Explain that each student in the group will add a food item from the market as he or she repeats the sentence until everyone in the group has a turn.

Place students in groups of four or five by combining partnerships. Select a leader for each group to start the sentence. Allow time for each member of the group to have a turn. When all groups finish, invite each group to repeat their list of items for the class.

Theme Exploration

TIMING GOAL: 15 minutes

Partnership Question of the Day



T-P-S: **Where does your family shop for food?**

Last week we talked about different kinds of food and how to make healthy eating choices. We know about where food comes from and how it gets to the store. This week we will talk about what happens to food once it reaches the store. Let's see what our Daily Message says.

Daily Message

Food is sold at markets.

- Write the Daily Message in front of students, reading each word as you finish writing it. Then read the entire message again, touching each word as you read it.
- Reinforce literacy objectives by pointing out the following:
 - Invite students to clap out the words in the sentence with you. Clap out the words as students count how many words are in the sentence.
 - Use Stretch and Read to have students read "is" and "at."

Theme Learning

- Explain the content of the Daily Message.

Our Daily Message tells us that food is sold at markets. Some markets are small shops, and others are large grocery stores, or supermarkets. Most people do their grocery shopping at markets. Let's watch this video and learn more about markets.



- Play the “Grocery Stores” video.

T-P-S: What is the first thing you usually do when you go food shopping?

RWE: One of the first things we do when we grocery shop is pick up a basket or grocery cart on our way into the store.

- Lead students in a walk around an imaginary grocery store.

Let's imagine that we are grocery shopping. I would like everyone to stand up and pretend to carry a grocery basket or push a cart. Pause as students ready themselves.

Is everyone ready? Good. Now, let's go on a walk around the store. Walk up and down the aisles, looking at the food on the shelves. Demonstrate walking down an aisle and looking at the shelves on either side of you. I see nuts, and popcorn, and other yummy-looking food in this aisle; let's see what's down the next aisle! Demonstrate walking down the next aisle and placing food in your cart or basket. Continue in this manner for several minutes, encouraging students to do the same.

Okay. I have everything on my list. T-P-S: What do I do now? RWE: Yes, if I have everything on my list, I am ready to check out.

- Invite students to take their seats. Explain what happens during checkout.

When I reach the checkout line, I have to unload my groceries. I take my groceries out of my basket or cart and place them on the conveyor belt. Then, the checkout person scans the price of each of my items and places them in bags. The last step is to pay, and then I get to take my groceries home!

This week we will learn all about markets. We will even have a supermarket in our classroom this week!



- Play the digital dictionary videos for “aisle” and “checkout.”
- Re-emphasize the theme-related vocabulary words. Post the words, or point to them on the interactive whiteboard, as you discuss each one.

Our two new words for today are “aisle” and “checkout.”

An aisle is a walkway between rows of seats or shelves. Grocery stores have aisles to separate the shelves in the store. I can make a sentence with the word “aisle.”

I walk up and down the aisles of the grocery store.

We pay for our groceries at the **checkout**. At the **checkout**, the cashier scans each item and places it in a bag. The cashier tells us the price of all the groceries, and then we pay. I can make a sentence with the word "**checkout**:"

When you go to the **checkout**, the cashier puts your groceries in bags.



Ask students to stand up as they sing "It's Time for a Rhyme" to signal the transition to Rhyme Time.

Rhyme Time

TIMING GOAL: 10 minutes

Say the Rhyme

- Introduce the rhyme "Food for You and Me."

Today we will begin to learn a new rhyme about food and where it comes from. Listen carefully; you might hear some rhyming words.



- Start the video to hear the audio and see the hand motions, or read the words and model the motions.
- Use My Turn, Your Turn to teach the rhyme to students, one line at a time.



Food for You and Me

Bakers bake our bread (Pretend to open an oven and pull out a tray of bread.)

And butchers cut our meat. (Make a chopping motion with your hand.)

Farmers out in the fields (Act as if sprinkling seeds.)

Grow food for us to eat. (Rub stomach.)

When everyone works together,

It's pretty plain to see (Point to eyes.)

We have a great big world of food (Extend arms to side.)

Enough for you (Use both hands to point to a friend.) **and me!**
(Use both hands to point to self.)

Develop Phonological Awareness—Counting Syllables

- Review the concept of syllables with students.

Words can be broken down into chunks. We call these chunks "syllables." Today we are going to count the number of syllables that we hear in words.

- Have one student pull a picture from the grocery bag and show the picture to the class. Ask the student to name the object. *Tomato*.
- Prompt the class to repeat, “This is a tomato.”
- Demonstrate clapping out the syllables. **To** (Clap.) **-ma** (Clap.) **-to**. (Clap.) Invite students to clap out the syllables with you.
- Ask students how many syllables they heard. *Three*. Clap out the word with students again if necessary.
- Repeat this process with the remaining objects in the grocery bag.

Student: (pulls item from grocery bag) **This is a** (banana).

Class: **This is a** (banana). **Ba** (Clap.) **-na** (Clap.) **-na**. (Clap.)

Teacher: **How many syllables are in “ba-na-na”?**

Class: **Three**.

Teacher: **Yes. There are three syllables in “banana.”** (Count on your fingers by putting up one finger as you say each syllable.) **Three**.



- Award pocket points if several students are able to successfully segment and count the syllables in the words.



Sing the song “Let’s Read Together” with students.



STaR
Interactive Story Reading

TIMING GOAL: 20 minutes

STaR Words:

list
grocer

Bunny Cakes

Written and illustrated by Rosemary Wells

Max and Ruby want to make a special cake for Grandma’s birthday. After Max makes his special earthworm birthday cake, he wants to help Ruby make an angel surprise cake with raspberry-fluff icing.

Ruby sends Max to the store with a list of needed ingredients, but Max has his own ideas for the list. Unfortunately, the grocer cannot read Max’s writing, so Max only brings home the items that Ruby has written on the list. Max figures out a solution that every emergent writer can appreciate.

Interactive Story Reading

Before Reading

- Introduce the title, author, and illustrator of the story. Have students identify the author's and illustrator's roles and the purpose of the title.



The name of our story is *Bunny Cakes*. WGR: What is another word for the name of a story? Title. *Bunny Cakes* was written and illustrated by Rosemary Wells. What did Miss Wells do for this story? She wrote the words and made the pictures.

- Have students preview the story. Guide them as they make predictions about the story based on the cover illustration and the title.



Display the front cover of the book. **The title of the story is *Bunny Cakes*. T-P-S: What ideas do you get from the illustration on the cover about what the story will be about?** Restate some of the students' responses, noting the different ideas they have based on their inferences about the title and illustration.

- Introduce the story vocabulary words.

We will hear the word “list” many times in this story. It's an important word in the story. When you make a list, you write words on paper. People often make a list of things they need at the market before they go shopping. A list helps them remember what they want to buy.

Another new word is “grocer.” A grocer is a person who works in a market. The grocer puts food on the shelves, helps you find what you need, or tells you how much your food costs. T-P-S: Tell your partner about a time when you went to a market. What was the grocer doing when you were there?

- Introduce the good-reader skill for today.

Good readers think about whether stories could actually happen in real life. As I read the story today, think about whether or not it could be a true story.

During the story, ask students, **Could that have happened in real life? Why or why not?**



Relate story plots to reality.

During Reading



- Use Think-Pair-Share or Whole-Group Response to engage students in an ongoing discussion about the story as guided by the questions and comments below.

– **Page 3:** Read the text on the page without reading the word “eggs” that appears on the notepaper at the bottom right of the page.

T-P-S: **What happened?**

– **I heard the new word “list” on this page. When you make a list, you write words on paper.** Point to the notepaper with the word “eggs” on it. **This is the list that Ruby writes for Max. It has one thing written on it. WGR: What do you think Ruby writes on the list for Max to buy at the store? Eggs.**



- **Page 5:** “Grocer” is a new word. In this story, the grocer is giving Max the eggs he needs. T-P-S: Why can't the grocer read Max's writing for the Red-Hot Marshmallow Squirters?
- **Page 7:** T-P-S: Why does Ruby send Max back to the store? *Max bumps the table, and the milk spills.*
- **Page 9:** T-P-S: What does Max write on the list after Ruby writes “milk”?
- **Page 11:** T-P-S: Why do you think Ruby gets out her pencil?
- **Page 14:** T-P-S: Why do you think Ruby puts a sign on the door for Max to stay out of the kitchen? RWE: Max bothers Ruby while she's making her cake. Ruby seems to be angry with Max, so she wants him to stay out of the kitchen. T-P-S: Do you think a sister would tell her brother to stay out of the kitchen in real life? Why (or why not)?
- **Page 17:** T-P-S: What do you think Max's idea is?
- **Page 19:** T-P-S: What does Ruby do to give Max the idea to draw Red-Hot Marshmallow Squirters on the list? How do you think Max feels now that the grocer can read what Max wrote on the list?

After Reading

In the story *Bunny Cakes*, a brother keeps knocking things over while his sister is making a cake. The brother goes to the market to get more ingredients for Grandma's birthday cake. Do you think this could happen in real life?



WGR: Where does Max go to get the ingredients for the cake?

- Make summative statements about the story that reinforce the STaR vocabulary. Guide students to make sentences with the words.

Ruby wants to make a cake for Grandma's birthday, but when Max breaks the eggs and spills other ingredients, Ruby needs some things from the market. She writes down the things she needs so Max can get them. This reminds me of our word “list.” Let's make a sentence together using the word “list.” T-P-S: **Talk to your partner about ideas that you have for our sentence.**

- Use students' ideas to develop a sentence. Write the sentence on the board in front of students, saying each word as you write it. Repeat with the word “grocer.”



Use the 1-2-3 Move signal to move students from the STaR area to the dramatic play lab for the beginning of the lab tour.



Learning Labs

TIMING GOAL: 40 minutes

Routine

1. Have a lab tour to explain the activities or materials in any new labs.
2. Guide students as they select the lab that they will visit. Use the lab-management system to ensure that not too many students plan to visit the same lab at the same time.
3. Students will complete their Learning Lab plan. Conference with as many students as possible about their writing before they are dismissed to labs.
 - Write the code for the writing stage exhibited by the student in the top right-hand corner of the student's paper.
 - Use the methods described in the *Writing Development Feedback Guide* to provide feedback.
4. Monitor students as they visit their selected labs.

Dramatic Play Lab | KinderCorner Market

Description:

- The dramatic play lab will be a market.

Purpose:

- Participation in this lab will reinforce thematic concepts and help students to develop cognitive skills through role play and the creative use of props. It will also help to develop oral language.

When You Tour:



- Explain that today the dramatic play area will be a market. Use Think-Pair-Share to have students identify the different roles that they could play in a market. *Customer, cashier, stocker, butcher, owner, delivery person, etc.* Remind students to specify which roles they would like to play as they write their lab plans.
- Point out the different props and materials that students will find in the area. Use Think-Pair-Share to have students discuss what kinds of props they can create for the market. *Signs, shelves, a cash register, cans, produce, etc.*

Facilitate Learning:

- Ask questions that will help students to develop mature levels of play by prompting them to think about their roles, the props, and the rules they created for the scenario. For best results, jump in, and join the play as you interact with students.

Examples:

- (As a customer) **Can you tell me where I can find cheese?**
- (As a butcher) **What kind of meat would you like today?**

- As students develop their play in this lab throughout the week, observe which ones dramatize buying and selling objects.

 As you did in the dramatic play lab for KinderCorner Cafe, observe students to determine their knowledge about working in a supermarket. If necessary, provide scaffolding that extends and enriches their play and that also teaches literacy skills. Take on the role of one of the workers, for example, the stock person, and think aloud, "These boxes of food have been delivered from the warehouse; what should I do with them? I can put them on the shelves for the customers to buy."

Blocks Lab | Off to the Market

Description:

- Students will use trucks to deliver fruits and vegetables to the market.

Purpose:

- Participation in this lab will help students to develop fine-motor skills, cognitive skills through role play, and oral language.

When You Tour:

- Point out the addition of boxes and trucks to the lab. Say, **You can pack the boxes with fruits and vegetables and take them to the supermarket in the dramatic play lab on the trucks. When people go to the supermarket, they want to have lots of choices of food to buy.**
- Invite students to combine the blocks and dramatic play labs this week. Have them describe the foods they are packing and predict how many items will fit in each box.

Facilitate Learning:

- Encourage students to describe the fruits' and vegetables' journey from the farm or packing house to the supermarket.

Art Lab | Shopping Bags

Description:

- Students will decorate shopping bags for the KinderCorner Market.

Purpose:

- The lab will reinforce thematic concepts and provide the opportunity for students to make choices about what they would like to make and the materials they would like to use to stimulate creativity.

When You Tour:

- Point out the brown paper grocery bags (or canvas bags), paper, paints, fruits, vegetables, and other foods (See the note below.) for making prints. Demonstrate how to apply a thin coat of paint to one of the available foods and then use it to make a print on one of the paper or canvas bags. Say, **You may decorate grocery bags with any of the available foods. When the paint dries, you can use the bags in the supermarket in the dramatic play lab.**
- Alternatively, students may paint designs or draw food items on the bags.

Facilitate Learning:

- As you visit during lab time, comment on students' color choices.
- Ask questions about how they made their choices and which foods they used to decorate the bags. You might bring in bags from local stores and read what is written on them to reinforce the fact that words are written on grocery bags.
- Take this opportunity to observe which students explore creative art materials.

Classroom Library Lab | Free Reading

Description:

- Students will have the opportunity to explore books independently or with a friend. Theme-related books will be added to the regular classroom library.

Purpose:

- This lab provides practice with correct book handling and the opportunity to explore letters, words, and sentences in the context of a book. For some students, this lab provides practice with reading.

When You Tour:

- Point out any new books or pamphlets that you have added to the lab. Remind students that if they would like to read one of the books with a friend, even if they are just pretending, they can use the ear and mouth cards to help take turns reading and listening.

Facilitate Learning:

- Use this opportunity to provide guidance or coaching to students who have not demonstrated mastery of objectives as indicated on the weekly record form.

Literacy Lab | Play School

Description:

- Students will use materials commonly found in classrooms to play school.

Purpose:

- Participation in this lab provides students with an opportunity to develop cognitive skills through role play and the creative use of props. It will also help to develop oral language and literacy skills.

When You Tour:

- Encourage students to play school. Have students name the different roles that could be played in a school setting.
- Point out the available materials, and remind students that they can also make things they need with items from the Wonder Box.

Facilitate Learning:

- So as not to interrupt the play, interactions with students in this lab should be done through role play. Announce who you are (a new student, the principal, a parent, a teacher next door), and join in.

Math Lab | The Right Price

Description:

- Students will create price tags for the food items in the KinderCorner Market.

Purpose:

- Participation in this lab will allow students to practice their fine-motor skills when they write a price on each tag. Students will practice thinking about reasonable prices for items and will gain exposure to price-writing formats from the store circulars.

When You Tour:

- Explain to students that they may make price tags for items in the KinderCorner Market. Show them the grocery-store circulars that they may use as references for determining prices. Explain that they can get supplies from the writing or art labs, if needed, for their price tags. They may also bring their price tags to the KinderCorner Market when they are finished.
- Remind students that prices have a dollar sign in front of them. Point out the page with the sample prices to remind students how to write prices.

Facilitate Learning:

- Encourage students to use their imaginations, and reinforce theme-related vocabulary by joining in on the play. Ask questions, or make statements, that will communicate your role.

Example:

- **I'm the manager over at the KinderCorner Market, and I was just checking to see how the price tags are coming along. We want to make sure that the prices posted in the food aisles match what customers are being charged at the checkout.**

Computer/Media Lab | Free Exploration

Description:

- Students will explore educational software or listen to music with computers, CD players, or other digital devices.

Purpose:

- This lab provides students with an opportunity to explore technology, reinforce literacy concepts in a new context, or enjoy music.

When You Tour:

- Remind students that they can use educational software or listen to music with computers, CD players, or other digital devices.

Facilitate Learning:

- Take time this week to visit with students in this lab and to engage in discussion about the music they are listening to or the software they are using.

Sand/Water Lab | Free Exploration

Description:

- Students will explore the properties of sand and/or water by experimenting with a variety of tools.

Purpose:

- This lab provides students with an opportunity to investigate the natural world with a focus on water and sand.

When You Tour:

- Remind students of any new tools or materials that you have placed in the lab.

Facilitate Learning:

- Ask questions that will help students to think about the nature of sand and water and the tools and materials in the lab. For best results, jump in, and join the play as you interact with students.

Examples:

- **How could we build a _____?**
- **Tell me about that _____ you are working on.**

Science Lab | Nutrition Lotto

Description:

- Students will play the Nutrition Lotto game with peers.

Purpose:

- This lab provides reinforcement of thematic concepts and provides students with the opportunity to direct their own play with a game that was used in a class setting during the first week of the unit.

When You Tour:

- Explain that students may play Nutrition Lotto with their friends. Explain that they may play the game the way it was played in class last week, or they can make up their own game with the materials.

Facilitate Learning:

- Join in the game as a player. Use thematic vocabulary from week 1 when possible as you converse with students.

Writing Lab | Make a List, Please

Description:

- Students will write grocery lists.

Purpose:

- This lab provides students with an opportunity to practice writing that is related to the theme.

When You Tour:

- Tell students they can write grocery lists for the market.
- Point out the paper and writing implements for students to use when they write their lists.
- Remind students that they may write their lists in their own ways and that if anyone needs help reading a list, he or she can ask the writer for assistance.
- Encourage students to think about how they will write their lists. Remind them that they know many sounds and letter shapes to create words.

Facilitate Learning:

- Remember to encourage, accept, and celebrate all forms of writing development.
- Encourage students to use numbers to show how many of each item they want to buy.
- Observe which students demonstrate an increased facility with the process of writing, which students demonstrate an increasing awareness of the function of writing, and/or which students demonstrate an interest in writing to communicate.

 Some teachers find it easier to make a photocopy of each student's writing, date it, and add notes so they can place it in the student's portfolio to be shared during parent conferences.



Provide five-minute and three-minute warnings before the end of the labs. Then sing the clean-up song to prompt students to put away the lab items and move to the 15-Minute Math board.



15-Minute Math

TIMING GOAL: 15 minutes

Complete the following activities as described on day 1.

Calendar

Days of the Week

Days of School Tape

Ten-Frames

Hundreds Chart

Number-Recognition Circle 6–10

- Clip the clothespin to the section of the circle with the number 7 on it. Ask students to identify the number. 7. **Let's count aloud as we hop seven times.**
- Move the clothespin to the section of the circle with the number 6 on it. Ask students to identify the number. 6. **Let's count aloud as we clap six times.**
- Move the clothespin to the section of the circle with the number 8 on it. Ask students to identify the number. 8. **Let's count aloud as we touch our toes eight times.**
- Point to and name the numbers 6, 7, and 8 on the circle.



Recite the Stop and Stay Cool rhyme as students move to the area where you will serve the snack.



Snack • Outside • Gross-Motor Play

TIMING GOAL: 30 minutes

Snack

- Offer a wide variety of healthy foods from the food groups (except fats, oils, and sweets) that you focused on last week. Allow students to choose a small amount from each group of foods. Talk with students about why these foods are good choices for them and how the foods help them grow. Expand on the concept of the different kinds of foods that are available in markets and how all these snacks came from just one supermarket.
- Invite students to participate in the Partner Challenge. **Our Partner Challenge is to practice the steps of Stop and Stay Cool with your partner. During Gathering Circle, one partner showed the steps for Stop and Stay Cool. This time when you practice, be sure the partner who helped before is the first one to show the steps this time.**
- Allow time for students to practice. Make sure both members of each partnership have a turn showing the steps.
- Award pocket points when students demonstrate all the steps of Stop and Stay Cool.



Outside/Gross-Motor Play

- For students who are interested in a structured play activity, play the exercise game To Market, To Market. Establish a starting (to market) line and finishing (home again) line several feet apart from each other. Have students stand behind the starting line and walk (jog, skip, hop, etc.) toward the finishing line as you chant, “To market, to market, to buy a fat pig” (“fat hog,” “plum bun,” etc.). When you chant, “Home again, home again...,” have students return, moving back toward the starting line.



When students come back inside, select one student to play teacher. As students return to the gathering area for Stepping Stones, that student will point to each word on the word wall for the other students to read.



Stepping Stones

TIMING GOAL: 30 minutes

Beginning Phonics

- Point to each mnemonic picture on the wall frieze, and ask students to name each picture.
- Show the Animated Alphabet segments for /sh/, /z/, and /w/.



Emergent Reading

Story Introduction

- Show the cover of *At the Market*. Introduce the title and author.

We've been talking about markets, or grocery stores, today. This story tells us about many kinds of foods that we can buy at a market.

Look at the picture on the cover. T-P-S: What is the woman in the picture selecting at the market? Radishes; vegetables. RWE: She will buy some vegetables called radishes. This woman is shopping in the produce department. In the produce department, you can buy fresh fruits and vegetables.

I wonder what other aisles in the market we will see in our book.

- Introduce the focus skills.

Show the word card for "you." This is a word that we have already seen many times, and we will see it in our story. The word is "you." Show the first page of the book, and read the words. Invite a volunteer to point to the word "you" on the page. Point to the word "the." We know this word too. WGR: What does this word say? The. Add the word card for "you" to the word wall. Quickly review all the word-wall words.

We can use Stretch and Read to read another word from our sentence.

Write the word "can" on the board, or point to it in the sentence from page 1 if all students can see it. Lead the class to stretch and read the word "can."



Read the remainder of the story to students. Discuss the location of each picture as you read each page.

- **Page 1: This bread might be in a bakery department of a supermarket.**
- **Page 2: This milk is in the dairy department of a supermarket.**
- **Page 3: These vegetables are in an open market outside. Many other countries have open markets. In the United States, most open markets are called farmer's markets.**
- **Page 4: This big fish is in the seafood department. Some supermarkets have their fish in the meat department. Fish and other meats must be kept cold to stay fresh. Point out the refrigerated case.**
- **Page 5: This is another outdoor market where fruit is sold.**
- **Page 6: These customers are in the frozen-food aisle of a supermarket. We can tell because of the big freezers. T-P-S: What kinds of foods can you find in the frozen aisle at the supermarket? *Frozen dinners, pizza, ice cream, waffles, bags of vegetables, etc.***

Guided Group Reading

- Distribute a book to each student. Read the book again, this time inviting students to read in unison with you as they follow along in their own books.

Skill Reinforcement

- Distribute a set of word-and-picture matching cards to each partnership. Ask students to use the sounds in the words and also the pictures and words in the books to match the words and pictures.
- Review the correct answers by rereading the book and showing the word and picture cards that go with each page as you do.
- Award pocket points if most partnerships are able to match their words and pictures correctly.



Invite students to sing “March to Math” to signal that it is time for Math Mysteries.

Math Mysteries

TIMING GOAL: 25 minutes

Show What You Know

- Have students say the following chant with you.

We've learned other ways to count. Let's try this chant.

5, 10, 15, 20

Count by 5s—We know plenty!



- Show students the number card for the number 10.

T-P-S: We've learned a lot about the numbers 1–10. What number comes after 10?



RWE: The number that comes after 10 is 11.



- Award pocket points if students are able to identify the number.
- Ask students to identify Number Cards as you show them (for the numbers 1–10.) Hold up each card one at a time, and ask students to identify the number.



WGR: What number is this?

Active Instruction

- Explain to students that today they will learn about numbers that are more than other numbers.
- Point out the two circles on the floor. Select five students to move into one of the circles.



WGR: How many students are in this circle? Count with me.

- Select seven different students to move into the second circle.

WGR: How many students are in this circle? Count with me.

- Introduce the concept of more than.



T-P-S: Let's compare these groups, or see how they are the same and different. Both of these groups have students in them, but I see something different about these two groups. What's different about these groups?

One group has seven students, and one has five students. One group has more.

- Explain that one group has more students in it than the other. Show the Ten-Frame Cards for the numbers 7 and 5. Point out that the Ten-Frame Card for the number 7 has more dots than the Ten-Frame Card for the number 5, just like the group with seven students has more students than the group with five students.
- Ask the students in the circles to return to where they were sitting. Call on eight different students to move into one circle and six different students to move into the other.

T-P-S: Which group has more students? How do you know? *The group with eight students has more than the group with six students. You can see that there are more students.*

- Hold up the appropriate Ten-Frame Cards to reinforce which group has more. Continue with varying sets of numbers until all students have had an opportunity to have a clear understanding of “more than.”

Partner Practice

- Give each student a Circle Workmat and a bag of twelve linking cubes. Give each partnership a set of Ten-Frame Cards for the numbers 1–10.

Now you are going to use cubes to make sets that are more than the numbers shown on the Ten-Frame Cards on your Circle Workmats.

- Show the Ten-Frame Card for the number 5. Ask students to make a set that is more than five on their Circle Workmats. Point out that not everyone has the same number of cubes on his or her workmat, but that everyone made a set that is more than five.

You and your partner will take turns choosing Ten-Frame Cards. Then you will each build a set that is more than that number on your Circle Workmat, like we just did. You and your partner may have the same number of cubes, or you may not. You will count your partner's cubes and compare that set with the Ten-Frame Card to make sure that his or her set is more than the number shown on the card. Once you have checked each other's sets, you can clear your workmat and start over again.

- Model this activity if necessary.
- Circulate as students work. Encourage students to count their partners' cubes to check that their sets are more than the number on the selected card. Note any students who have difficulty with the concept of more than.

Recap

- Show the Ten-Frame Card for the number 4, and use the sharing sticks to select students to make a set that is more than four. Award pocket points if several students are able to successfully create a set that is more than four.
- Play the “Scooter Counting Books (more)” video.
- Review the concept of more than.

T-P-S: How can we tell if one set has more than another set?

RWE: We can count the sets to see which one has more. We can look at them to see which set may have more. We can put the cubes together and put them side by side to see which set has more.



Sing “It's time to go to sleep. It's time to count our sheep.” Then count in a quiet voice, touch each student lightly on the head, and send them to retrieve their nap-time supplies.

Let's Daydream

TIMING GOAL: 25 minutes

Routine

1. Have students get out their supplies (towels, cots, etc.) for nap time.
2. Read the selected poetry, and play soft music (optional) as students rest.
3. Allow students to quietly look at another book during this time if they prefer.

Recommended Poetry Selection

- “The Noise of Nothing,” *The 20th Century Children’s Poetry Treasury*, page 14

Introduce the Poem

Today’s poem is about sound—the sound of nothing! What is the sound of nothing? Let’s listen to what this author says.



Gather students in a place where you will model during Write Away.

Write Away

TIMING GOAL: 20 minutes

Prewriting

- Present the writing topic for the day, and encourage students to share their ideas. To discourage copying later, do not write the ideas on the board.

Today we have been talking about how food is sold at markets. You are going to write a shopping list to take to a market.



Think about all the different foods that are sold at a market. What would you put on your shopping list for the market?

- Share an example that applies to you.

I think that I will write a list that says, “Apples, Juice, Bread, Pretzels, Chicken.”

- Review previously introduced emergent-writing strategies.

T-P-S: What are some things that I can do if I don’t know how to write some of the words in my sentence? Draw a picture, draw a line, write sounds that I know, copy a word, and remember a word.

I will use these things to make my list. You can use them when you make your list too.

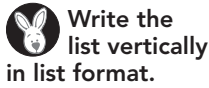

- To model writing your sentence, use the writing strategies that have already been introduced. First, count the words on your fingers as you say the sentence again. Then, draw lines on the board to represent each word.

Example:

I am ready to write my list. My list is, “Apples, Juice, Bread, Pretzels, Chicken.”

- **The first word is “apples.” I’m going to draw a picture for “apples.”** Draw a picture of apples on the first line.
 - **The next word is “juice.” What sounds that we have learned do you hear in “juice”?** Say the word slowly, emphasizing the individual sounds. Write any letters that students say.
 - **“Bread.” I hear some sounds that I know in “bread.” I hear /b/, /r/, and /d/. Write each letter as you say the sound.**
 - **“Pretzels.” I can also draw a picture for “pretzels.”** Draw a picture of pretzels.
 - **The last word is “chicken.” Do you hear any sounds that you know in “chicken”?** Say the word slowly, emphasizing the individual sounds. Write any letters that students say.
- Reread your sentence, touching each word, or word representation, as you do.

Partner Planning

- Ask students to share what they would like to write with their partners. Encourage them to use the Say-It-Back strategy to show their partners that they are listening.
- Monitor students, and listen to their discussions. Ask one or two students what their partners are planning to write.

Writing

- Distribute pencils and either writing journals or paper.
- Monitor students as they write. Encourage them to use the writing strategies that you have introduced as needed.
- Hold a writing conference with a few students as time permits. Record the stage of writing that you observe for some students on the weekly record form.

Sharing

- Ask students to share their sentences with their partners.
- Use the sharing sticks to select one or two students to share their writing with the class. Acknowledge and celebrate any emergent-writing strategies that they have used.



Invite students to recite or sing “Let’s Think About It” as they move to the gathering area.



Let's Think About It

TIMING GOAL: 20 minutes

Theme-Learning Recap



- Review the learning focus of the day.

This week we are learning about markets. Markets are places where food is sold. You might also call the market the food store, grocery store, or supermarket. When they go shopping, some people take a list of all the food they want to buy. This grocery list helps them so they don't forget to buy anything!

When you enter a grocery store, you usually pick up a basket or cart.

T-P-S: Why might you do this? *You put all of your food in the basket or cart.*

If you buy a lot of food, you would not be able to carry it all by yourself. Right.

Once we have our basket or cart, we walk up and down the aisles of the store to find everything on our list. The last step is to go to the checkout line. T-P-S: What happens at checkout? *The cashier scans your food. The food is put in bags. You pay for your food.*

- If you have arranged a field trip to a grocery store this week, ask students about the types of things they think they will see at the grocery store.
- Use Think-Pair-Share to have students come up with questions they might like to ask someone who works at a grocery store.

If you are planning a field trip to a grocery store this week, create a list of students' questions to take with you to the store.

If you are not able to visit a store, take this opportunity to write a class letter to the manager of a local grocery store. Incorporate students' questions in the letter. For example, you might write, "We are learning about food markets. Kimberly and Lamar want to know how many kinds of fruits are sold at the store. Danny, Jess, and Bryan wonder how the frozen food stays cold." Mail, or deliver, the letter to your local grocer, and encourage him or her to write a letter back to the class.



Vocabulary Review

- Briefly review the new theme-related vocabulary words. Use My Turn, Your Turn to have students practice saying each word. Then provide a brief definition, and make connections to the contexts in which the word was used today.

One of our new words today is "aisle." We use the word "aisle" to describe a walkway between shelves or seats. T-P-S: When did we see, hear, or use the word "aisle" today?

Our other new word today is "checkout." Before you leave the grocery store, you must stand in the checkout line and pay for your food. When did we see, hear, or use the word "checkout" today?



- Ask partners to work together to think of a sentence that uses one of the words. Use the sharing sticks to select a student to share the sentence with the class. Use the Oral-Language Scoring Rubric to score the response. Record the score on the weekly record form.

| Oral-Language Scoring Rubric | |
|------------------------------|---------------------------------------------------------------------------------------|
| 70 | The student does not respond, or the response does not make sense. |
| 80 | The student responds with a word or phrase that makes sense. |
| 90 | The student responds in a complete sentence that makes sense. |
| 100 | The student responds in a complete sentence(s) that makes sense and includes details. |

- Use the suggestions below to help foster oral-language development.

Theme Vocabulary:

aisle
checkout

| Fostering Richer Language | | |
|---------------------------------------------------------------------------------------------------------|------------------------------------------------------------------------------------------------------------------------------------------|-----------------------------------------------------------------------------------------------------------------------------------------------------------------------------------------------|
| Student Response | Teacher Prompt | Further Prompting |
| The student responds in an incomplete sentence. Store has aisles. | Good answer. Can you say that in a complete sentence? | If the student is unable to respond in a sentence, model a sentence for him or her. <i>We can say, The grocery store has aisles.</i> |
| The student responds in a complete, but not very elaborate, sentence. I like the candy aisle. | You made a complete sentence with the word. Can you add some details to your sentence? OR Can you tell us a little more about the _____? | If the student is unable to add details, prompt with a question about the sentence. Can you tell us more about the types of candy you find in the candy aisle of the grocery store? |



- Award pocket points if the student is able to create a complete sentence.

Partner Challenge

- Review the Partner Challenge of the day.

We have one more opportunity to earn pocket points today! Let's review our Partner Challenge. Our Partner Challenge is to practice the steps of Stop and Stay Cool with your partner. We can do the Partner Challenge again now. Allow time for both members of partnerships to demonstrate the steps.



- Use the sharing sticks to select students to demonstrate for the class. Award pocket points when students show all the steps of Stop and Stay Cool.
- Invite students to compliment the Cool Kid for successfully demonstrating Getting Along Together skills.

Pocket Points for the Day

- Empty the chips from KinderRoo's pouch, and encourage students to join you in counting them.
- Pour the chips into the jar, and observe how close the total is to the reward line.
- Remind students about their reward.

Home Link/Departure

- Invite students to tell their partners one thing that they did or learned today at school.
- Make any announcements or give reminders (upcoming field trips, picture day, etc.).
- Remind students to watch tonight's Home Link show. Tell students to click on the lion for today's show.
- Read & Respond: **Share a book with someone in your family. Ask him or her to sign your Read & Respond bookmark.**
- Use the lion stamp to place an animal image on each student's hand.

Day 7 | Ready, Set...

Focus

Foods are sorted into categories at the market.

| Additional Materials Needed Today | |
|--------------------------------------------|--------------------------------------------------------------------------------------------------------------------------------------------------------------------------------------------------------------------------------------------------------------------------------------------------------------------------------------------------------------------------------------------------------------------------------------------------------------------------------------------------------------------------------------------------------------------------------------------------------------------------------------------------------------------------------|
| Greetings, Readings, & Writings | <ul style="list-style-type: none"> Classroom Library Lab: Copies of the concepts-of-print book <i>At the Market</i> and the trade book <i>Bunny Cakes</i>, ear and mouth cards |
| Gathering Circle | <ul style="list-style-type: none"> Joey and Alex puppets Joey and Alex Stick Puppets Outline sheet (appendix) Scissors (one pair per student) Craft sticks (two per student) Tape |
| Theme Exploration | <ul style="list-style-type: none"> Grocery bag with food from the dramatic play lab and/or Nutrition Lotto cards Posterboard to create signs Markers Theme vocabulary word cards for “customer” and “department” or IWB access |
| Rhyme Time | <ul style="list-style-type: none"> KinderCorner 2nd Edition Plus Media and Software flash drive |
| STaR | <ul style="list-style-type: none"> Trade book: <i>Bunny Cakes</i> |
| 15-Minute Math | <ul style="list-style-type: none"> No new materials |
| Snack/Outside/ Gross-Motor Play | <ul style="list-style-type: none"> A sampling of vegetables Potato (beanbag or other object to use as the hot potato) |
| Stepping Stones | <ul style="list-style-type: none"> Key card for “y” or IWB access “Yy” Uppercase and Lowercase Letter Card Letter-Blending Cards (“y,” “e,” “sh,” “t,” “u”) or IWB access KinderRoo puppet /y/ picture cards (yield, yogurt) or IWB access Common /y/ objects (optional) Stepping Stones Partner Practice Booklets for unit 6 Individual writing boards and writing implements (or pencils if writing in the Partner Practice Booklets) KinderCorner 2nd Edition Plus Media and Software flash drive Concepts-of-print book (teacher and student copies): <i>At the Market</i> |

| Additional Materials Needed Today | |
|-----------------------------------|-----------------------------------------------------------------------------------------------------------------------------------------------------------------------------------------------------------------------------------------------------------------------------------|
| Math Mysteries | <ul style="list-style-type: none"> • Floor circles from day 1 • Ten-Frame Cards for 2–10, one set per partnership • Circle Workmat (appendix), one per student • Small plastic bags with twelve linking cubes each, one bag per student |
| Let's Daydream | <ul style="list-style-type: none"> • “Cats,” <i>The 20th Century Children's Poetry Treasury</i>, page 51 |
| Write Away | <ul style="list-style-type: none"> • No new materials |
| Let's Think About It | <ul style="list-style-type: none"> • Grocery Store Spinner (appendix) • Transparent spinner • Small paper bags, one per partnership • Chart paper and marker (optional) • Home Link animal hand stamp: walrus |

Learning Labs—Additional Materials

| |
|-----------------------------------------------------------------------------------------------------------------------------------------------------------------------------|
| Classroom Library Lab Free Reading |
| <ul style="list-style-type: none"> • Public and school library and STaR books related to the themes of seasons, fall, farming, harvest, leaves, plants, etc. |
| Sand/Water Lab Fill 'er Up |
| <ul style="list-style-type: none"> • Balance scale (optional) • Empty food containers |

Day 7

Greetings, Readings,
& Writings

TIMING GOAL: 15 minutes

| Student Routines | Teacher Routines |
|-------------------------------------------------------------------------------------------------------------------------------------------------------------------------|----------------------------------------------------------------------------------------------------------------------------------------------------------------------------------------------------------------------------------------------------------------------------------------------------------------------------------------------------------------------------------------------------------------------------------------------------------|
| <ol style="list-style-type: none"> 1. Remove coats and backpacks. 2. Turn in homework. 3. Sign in. 4. Self-select activities. | <ol style="list-style-type: none"> 1. Greet parents and students. 2. Remind students to read the Arrival Activities poster as they prepare for their day. 3. Encourage students to describe what they are doing in full sentences as you observe their activities. 4. Observe for student progress with their individualized objectives from the weekly record form. Circle demonstrated skills if applicable. |

Homework

- Read & Respond

Available Activities

Classroom Library Lab

- Display *Bunny Cakes* in a prominent place in the library. Invite students to explore the book. Also place a few copies of *Lunch Time* in the lab. Encourage students to practice reading the books with a friend.

Literacy Lab

- Same as day 6

Math Lab

- Same as day 6

Computer/Media Lab

- Same as day 6

Writing Lab

- Same as day 6

Other

- If you have any theme-related puzzles or games, make them available.



Sing a transitional gathering song. Encourage students to sing along as they move to the gathering area.



Gathering Circle

TIMING GOAL: 20 minutes

Routine

1. Welcome students to the Gathering Circle.
2. Check attendance.
3. Discuss yesterday's homework assignment. Award pocket points if at least half the students completed their homework.
4. Remind students about the responsibilities associated with each classroom job as needed.
5. Make sure that students are sitting with their partners for the week.
6. Remind students about the responsibilities of the Cool Kid.

Home Link Debrief

- Invite children to share what they remember from last night's Home Link show.



T-P-S: In last night's math video, Scooter is looking for something in his collection that has more than 6. Which collection did Scooter find that had more than 6? His fish pictures.



- Use the sharing sticks to select two or three children to share their responses with the whole class. Award pocket points in recognition of students' efforts.

Active Instruction

- Review Stop and Stay Cool with a puppet skit between Joey and Alex.

Let's see what's happening with Joey and Alex today.

As Joey: **Alex, hand me the red marker.**

As Alex: **No.**

As Joey, in an upset voice:

Alex, you're not even using the marker.

As Alex: **I'm not using it now, but I may need it later.**

As Joey, getting angry, shaking:

That's not fair! Give it to me!

As Alex: **I said no. Now leave me alone. You're bothering me.**

As Joey: **Alex, you're mean. I am so angry right now that I don't want to be your friend anymore!**



Joey and Alex are good friends, and they usually play well together. Today, though, Joey is getting angry. T-P-S: Where do you think Joey would mark a Feelings Thermometer to show how angry he is with Alex? If there are a variety of responses, help students agree on where to mark the thermometer. **WGR: What did we learn from Chilly that Joey can do before he gets too angry and loses control? Use Stop and Stay Cool.**

Let's tell Joey the steps so he can calm down. Have Joey demonstrate the steps as students name them.

As Joey: Thank you for helping me get cool and calm. I feel much better. And now I can try to talk with Alex about a way we can both use the markers.

Partner Practice

- Explain to students that they will be able to practice telling the story between Joey and Alex with their own Joey and Alex puppets. Distribute a stick puppet outline page, two craft sticks, and scissors to each student. Give students pieces of tape to adhere their puppets to the sticks as they cut them out.
- Once students have made their puppets, allow them to work with partners to act out the scenario and make the puppets do the Stop and Stay Cool steps.

Save the stick puppets for Gathering Circle on days 8 and 10.

Partner Challenge

- Introduce the challenge.

I'm glad we were able to help Joey use Stop and Stay Cool to calm down. If we keep practicing these steps, we'll become experts, and we won't have conflicts with our friends like Joey almost did. Our Partner Challenge today is to tell your partner why it was important for Joey to use Stop and Stay Cool. Allow a moment for students to think about the challenge. Remind them that they will have other opportunities during the day to talk about it more.

- Tell students they will earn pocket points when they use active-listening skills when they talk with their partners.



Theme Exploration

TIMING GOAL: 15 minutes

Partnership Question of the Day

 tps

T-P-S: Do you like going to the grocery store? Why (or why not)?

This week we are talking about markets. Another name for a food market might be a grocery store or supermarket. Let's see what our Daily Message says about where food is sold.

Daily Message

Foods are sorted into different departments at the supermarket.

- Write the Daily Message in front of students, reading each word as you finish writing it. Then read the entire message again, touching each word as you read it.
- Reinforce literacy objectives by pointing out the following:
 - **I see and hear some words that begin with the same sound.** Reread the Daily Message. T-P-S: **Who else hears and sees some words that begin with the same sound?** “Sorted” and “supermarket” both start with /s/ and “different” and “departments” both start with /d/.
 - **I see a word from our word wall in the Daily Message! WGR: What word do you know from our word wall?** “The.” Underline the word “the.”
 - Ask students to count as you clap out the syllables in “different,” “department,” and “supermarket.” Write the number of syllables above each word. WGR: **Which word has the most claps?** “Supermarket.” WGR: **How many claps are in the word “supermarket”?** Four. **Let's clap out this word together.**

Theme Learning

- Explain the content of the Daily Message.

When you go to the supermarket, you will hear people talk about the departments. A department is a space in the store that is set aside for the same types of foods. There are many departments in a supermarket. Point to the MyPlate poster. WGR: **Do you remember how we sorted the foods on our placemat? Yes. Let's review the names of the food groups together. Point to each group as students name it. Grains, fruits, vegetables, proteins, and dairy. Let's watch our video again and see how the store is separated into different departments.**

- Play the “Grocery Stores” video.

The store in the video had a dairy section for dairy foods, a deli section for meats—remember, meats are protein foods—and a produce section for fruits and vegetables.

- Introduce the following activity to help students understand why grocery stores are divided into departments.

I'm going to ask everyone to take a food item from this grocery bag and sort it into different departments in our KinderCorner Market in the dramatic play lab. Sorting foods into departments will make it easier for the customers and the workers to know where all the food is. Departments help customers know where to find particular groceries. Departments also help workers know where to put the groceries when they fill the shelves. I will say the name of a type of food. If you are holding that type of food, please bring it to the KinderCorner Market so you can sort it and create a special department in our store.

- Invite students to select a food item. Have all students with a grocery item from the grains group bring their items to the KinderCorner Market. Have students who are holding those items name them for the rest of the class. WGR: **What could you call the department where you can buy bagels, bread, muffins, and croissants** (or whatever items students have named)? *The bread department.*
- Have those students place their items in one section of the KinderCorner Market. **Let's write a sign to let the customers and workers know where the bread department is in our supermarket.** In large print on a posterboard, write "bread," asking students to help you with the beginning sound, /b/. WGR: **What sound do you hear at the beginning of "bread"?** /b/. Have students form the letter in the air as you write the letter on the posterboard while saying the cue, **Down the bat and right around the ball.** Finish writing the word "bread," and attach the poster in the area that will be the KinderCorner Market bread department.
- Continue to invite students to bring their grocery items to the lab in the same fashion. Call one group of food items at a time. Have students name the items. Then decide on a department name, and write the name on a posterboard. You might suggest an actual department name such as dairy, frozen food, produce, meat, deli, bakery, or seafood. Have students assist with the beginning sounds and letter formations of each department's label. Attach each poster to its corresponding department in the KinderCorner Market.
- When all the food items have been placed in their respective departments, point to each sign, and have students read it as a review.

Thanks for helping to organize the supermarket. Now it will be easier for customers to shop there and easier for workers to work there.



- Play the digital dictionary videos for "customer" and "department."
- Re-emphasize the theme-related vocabulary words. Post the words, or point to them on the interactive whiteboard, as you discuss each one.

Our two new words for today are "customer" and "department."

A customer is a person who buys something. When you shop at a grocery store, you are a customer of that grocery store. I can make a sentence with the word "customer:"

Today you can be a customer in our KinderCorner supermarket.

Grocery stores are divided into departments. Each department contains a special kind of food such as frozen foods or dairy foods. I can make a sentence with the word "department:"

When I buy bread, I go to the bread, or bakery, department.



Ask students to stand up as they sing "It's Time for a Rhyme" to signal the transition to Rhyme Time.

Rhyme Time

TIMING GOAL: 5 minutes

Say the Rhyme

- Have students recite "Food for You and Me." Encourage them to do the physical motions that accompany the rhyme.
- Read the words (see day 6), or play the video.



Develop Phonemic Awareness—Auditory Sound Blending

- Challenge students to say it fast after you say each of the words below in Joey Talk:

| | | | | | |
|---------|-----|----------|------|---------|-----|
| /c-u-t/ | cut | /f-oo-d/ | food | /b-i-g/ | big |
|---------|-----|----------|------|---------|-----|



- Award pocket points if students are able to successfully blend the sounds to make words.



Sing the song "Let's Read Together" with students.

STaR Story Retell

TIMING GOAL: 20 minutes

Review



- Review the title, author, and illustrator.

We read this story yesterday. Do you remember the title? Bunny Cakes.

WGR: The author is Rosemary Wells. What does the author do? *The author thinks of the story, writes the words.*

WGR: The illustrator is Rosemary Wells. What does the illustrator do? *The illustrator paints, draws, creates the pictures.*

- Review the story vocabulary words. Show the word on a word card or on the interactive whiteboard as you refer to it. Invite partners to make a sentence with each word.



We learned some new words in our story yesterday. The first word was “list.” What does “list” mean? Words on paper.

T-P-S: Can you think of a sentence that uses the word “grocer”? Work with your partner to think of a sentence.



- Use the sharing sticks to select students to share their responses. Award pocket points for successful responses.
- Repeat this process with the word “grocer.” *The word “grocer” means a person who works in a market.*

Story Retell

- Explain to students that they will act out the story with their partners.

Today when I read the story *Bunny Cakes*, you will be either Max or Ruby and act out the story with your partner.

- Assign roles to each member of the partnerships. Partner A is Max, and Partner B is Ruby.
- Have partnerships spread out so they have room to act out the story without crowding others.
- Read the story, pausing to allow students to act out the text.

Suggested stopping places:

| Page | Dramatize |
|------|----------------------------------------------------------------------------------------|
| 1 | Max making earthworm cake, Ruby watching |
| 4 | Ruby cracking eggs, Max writing Red-Hot Marshmallow Squirters on the list |
| 7 | Max bumping the table, Ruby giving Max another list |
| 10 | Ruby drawing a line on the floor, Max crossing it |
| 15 | Ruby making a cake, Max watching from outside |
| 18 | Ruby giving Max another list, Max drawing Red-Hot Marshmallow Squirters on Ruby's list |
| 21 | Ruby decorating her cake, Max decorating his cake |

- If time and students' interest allows, have partners switch roles, and read the story again.
- Close the activity by having students tell which cake they think Grandma will eat first.



T-P-S: Which cake do you think Grandma will eat first? Why?



Use the 1-2-3 Move signal to move students from the STaR area to the dramatic play lab for the beginning of the lab tour.



TIMING GOAL: 40 minutes

Routine

1. Have a lab tour to explain the activities or materials in any new labs.
2. Guide students as they select the lab that they will visit. Use the lab-management system to ensure that not too many students plan to visit the same lab at the same time.
3. Students will complete their Learning Lab plan. Conference with as many students as possible about their writing before they are dismissed to labs.
 - Write the code for the writing stage exhibited by the student in the top right-hand corner of the student's paper.
 - Use the methods described in the *Writing Development Feedback Guide* to provide feedback.
4. Monitor students as they visit their selected labs.

Dramatic Play Lab | KinderCorner Market

Description:

- The dramatic play area will continue to be a market.

When You Tour:

- Remind students that the lab is a market today. Ask students how the foods could be sorted in the market.

Blocks Lab | Off to the Market

Description:

- Students will continue to use trucks to deliver fruits and vegetables to the market.

Purpose:

- Remind students that they can deliver fruits and vegetables to the market.

Art Lab | Shopping Bags

Description:

- Students will continue to decorate shopping bags for the KinderCorner Market.

When You Tour:

- Remind students that they can decorate shopping bags for the KinderCorner Market.

Classroom Library Lab | Free Reading

Description:

- Students will have the opportunity to explore books independently or with a friend. Theme-related books will be added to the regular classroom library.

Purpose:

- This lab provides practice with correct book handling and the opportunity to explore letters, words, and sentences in the context of a book. For some students, this lab provides practice with reading.

When You Tour:

- Point out any new books that focus on the seasons, fall, weather changes, leaves, trees, harvest, etc.

Facilitate Learning:

- Observe students as they read or pretend to read the books in this lab. Notice whether they are holding the book upright and turning the pages from front to back. Talk with them about what they see happening in the illustrations.
- Throughout the week, read the titles of several books, and see if students can predict whether the book is mostly an informational book or a storybook. Be sure to have examples of each type.
- Use this opportunity to provide guidance or coaching to students who have not demonstrated mastery of objectives as indicated on the weekly record form.

Literacy Lab | Play School

Description:

- Students will continue to use materials commonly found in classrooms to play school.

When You Tour:

- Remind students that the lab is open today.

Math Lab | The Right Price

Description:

- Students will create price tags for the food items in the KinderCorner Market.

When You Tour:

- Let students know that the lab is open today. Remind them that they can get supplies from the writing or art labs, if necessary, for their price tags. They may also bring their price tags to the KinderCorner Market when they are finished.

Computer/Media Lab | Free Exploration

Description:

- Students will continue to explore educational software or listen to music with computers, CD players, or other digital devices.

When You Tour:

- Remind students that the lab is open today.

Sand/Water Lab | Fill 'er Up

Description:

- Students will fill up various containers with water and sand.

Purpose:

- This lab reinforces thematic concepts and provides students with an opportunity to predict, estimate, and weigh.

When You Tour:

- Point out the empty food containers that you have added to this lab.
- Explain to students that they can use the containers for filling and pouring.
- Suggest bringing the balance scale over to the sand/water area so students can compare the weights of various containers of sand and/or water.

Facilitate Learning:

- Join students in filling up the containers.
- When the containers are full, ask students how they compare with one another. Ask questions such as “Which holds more?” and “How do you know?” or “Which holds less?” and “How do you know?” Have students make predictions about how many of one container it will take to fill a different container. Ask, “How can you find out if your prediction is correct?”

Science Lab | Nutrition Lotto

Description:

- Students will play Nutrition Lotto.

When You Tour:

- Remind students that the lab is open today.

Writing Lab | Make a List, Please

Description:

- Students will continue to write grocery lists.

When You Tour:

- Remind students that they can make grocery lists.



Provide five-minute and three-minute warnings before the end of the labs. Then sing the clean-up song to prompt students to put away the lab items and move to the 15-Minute Math board.



15-Minute Math

TIMING GOAL: 15 minutes

Complete the following activities as described on day 1.

Calendar

Days of the Week

Days of School Tape

Ten-Frames

Hundreds Chart

Number-Recognition Circle 6–10

- Clip the clothespin to the section of the circle with the number 9 on it. Say, **Whisper to your partner which number is on the section with the clothespin.** Pause. Ask, **Which number is it? 9. How many dots are in this section? 9. Let's count them.** Point to the dots as you count them aloud. 1, 2, 3, 4, 5, 6, 7, 8, 9.
- **Now let's clap as we count to 9.** Clap and count together with students. Point to the number on the circle again, and ask, **What number is this? 9.**



Recite the Stop and Stay Cool rhyme as students move to the area where you will serve the snack.

Snack • Outside • Gross-Motor Play

TIMING GOAL: 30 minutes

Snack

- Serve a buffet of vegetables from the produce department. Encourage students to taste a variety of vegetables. Talk with them about why these foods are good choices for them and how vegetables help them grow.
- Invite students to talk about the Partner Challenge. Our Partner Challenge today is to tell your partner why it was important for Joey to use Stop and Stay Cool. Allow students time to talk with their partners about the challenge. Use Think-Pair-Share to review the parts of active listening as needed.
- Award pocket points when students use active listening with their partners.



Outside/Gross-Motor Play

- Play the game Hot Potato. Students stand in a circle close to one another. One student is randomly chosen to close his or her eyes. While the others quickly pass the potato around the circle, the student whose eyes are closed suddenly calls out, “Hot Potato!” The person holding the potato must jump up and down five times, and then he or she becomes the caller, and the game continues.



When students come back inside, select one student to play teacher. As students return to the gathering area for Stepping Stones, that student will point to each word on the word wall for the other students to read.

Stepping Stones

TIMING GOAL: 30 minutes



Beginning Phonics: /y/ – a bounced sound

Review

- Have students name each mnemonic picture as you point to it on the wall frieze.
- Ask students to provide the sounds for letters that have already been introduced with uppercase and lowercase cards attached.
- Show the Animated Alphabet segment for /v/.



Introduce the New Sound

Silly Sentence

- Present the KinderRoo puppet. Explain that she has a new sound for them to learn—a sound that they will hear in the silly sentence she has brought.
- Say the alliterative phrase two or three times, emphasizing the /y/ sound at the beginning of each word by softly bouncing it.

Yank the yellow yo-yo.

tps

- Use Think-Pair-Share to ask, **What sound do you hear at the beginning of “yank,” “yellow,” and “yo-yo”?**
- Explain that the /y/ is a bounced sound. When we say it, we want to be careful to say it softly and quickly, like the motion of a bouncing ball. We have to be careful not to say /yuh/.

My Turn
Your Turn

- Use My Turn, Your Turn to have students repeat each of the words that begin with /y/, softly bouncing the /y/ sound at the beginning of each word.

Let's practice that sound.

Teacher: /y/ ank

Students: /y/ ank

Teacher: /y/ ellow

Students: /y/ ellow

Teacher: /y/ o-yo

Students: /y/ o-yo

Mnemonic Picture

- Show the picture side of the key card for “y.” Explain that the picture we have to help us remember the sound /y/ is a yo-yo.



Let's watch our funny cartoon about /y/. It will help us to remember the sound.

- Play the Animated Alphabet segment for /y/. Point out that the kids make the /y/ sound as they play with their yo-yos.

People, Pictures, and Objects

- Have KinderRoo help you identify any students whose names begin with /y/. Explain that KinderRoo has brought some pictures and objects that begin with /y/. Say the name of each picture or object as you present it, and emphasize the /y/ sound.

yield

yogurt

- Ask students to name each picture or object as you point to it. Ask, **What sound do you hear at the beginning of _____?** as they name each one.



Making the Sound

- Ask students to think about what is happening in their mouths as they make the /y/ sound. Have them face their partners and make the sound several times as you ask the following questions:
 - **Is your mouth open or closed when you make the sound?**
 - **What is your tongue doing when you make the sound?**
 - **Gently touch your throat. Can you feel a vibration when you make the sound?**

Compare Uppercase and Lowercase

- Use the Uppercase and Lowercase Letter Cards to show students what both forms of the letter look like.
- Attach the uppercase and lowercase card next to the corresponding mnemonic picture on the wall frieze.



How are the two letter shapes the same? How are they different?

Partner Practice

Reading Sounds

- Distribute the Partner Practice Booklets and a crayon or pencil to each student. Ask students to open their booklets to page 8. Encourage partners to help each other find the page. Have the partners work together to read the sounds.
 - Jelly will point to the sounds, and Peanut Butter will read them. Jelly will help as needed.
 - After Peanut Butter has finished reading the sounds, Jelly will write their initials in the box at the bottom of Peanut Butter's page.
 - Peanut Butter will point to the sounds, and Jelly will read them. Peanut Butter will help as needed.
 - After Jelly has finished reading, Peanut Butter will write their initials in the box at the bottom of Jelly's page.

Stretch and Read

- Explain that the sounds we have been learning can be put together to make words. Model the process by placing the letter cards for /y/, /e/, and /t/ a few spaces apart in a pocket chart or along a chalkboard tray. Gradually move the letters closer together, and have students blend the sounds together with you until you say “yet.” Repeat with the word “shut.”

We know that words are made of sounds. We can read a word by saying all the sounds and blending them together. We call this Stretch and Read.

Alphie and his friends can use Stretch and Read to sound out words too. Let's watch.



- Show the Sound and the Furry video segment.

Now you will get to use Stretch and Read to read some words with your partner. The words you will read are different from the words we read together. Let's see who can figure out the words!



- Have students work with their partners to read the words from their Partner Practice Booklets using Stretch and Read.
- Use the sharing sticks to select a student to read the sounds for the class. Select another student to read the words. Provide assistance as needed. Award pocket points if they attempt to read all the sounds or words.

Forming the Letter

Introduce the shape of /y/.

- Explain that now you will show students how to write the letter that makes the /y/ sound. Trace the letter with your finger as you say the letter-writing cue “Slant right down one string and way down the other.” Ask students to say the cue with you two or three times as you trace the letter again.
- Show the letter-only side of the key card. Make a connection to the letter shape and the mnemonic picture.

Example:

- **What picture does this letter look like? Yo-yos. Yes, this letter looks like yo-yos.**

Write /y/.

- Demonstrate writing the letter in front of students several times on a writing board or chart paper. Ask students to say the writing cue with you as you form the letter.
- Hold the picture side of the key card next to the letters you have written. Ask students whether your letters look like the yo-yo. Place the key card in a pocket chart with the letter side facing outward.
- Guide students to practice forming the letter shape using their fingers as pencils several times in different ways (in the air, on the carpet, on their legs, etc.). Encourage them to say the cue as they write the letter.
- Distribute individual whiteboards and dry-erase markers, chalkboards and chalk, or paper and pencils or crayons. You may also use the space provided in the Partner Practice Booklet for writing. Ask students to write /y/ several times, reciting the cue with them each time.
- Ask students to examine their partners' letters for /y/ and circle the best one. Encourage them to tell their partners why they think it's the best.
- Have students write other letters that they have learned. Encourage them to say the cue as they write each letter.
 - /v/ **Down one wing and up the other.**
 - /j/ **Down Jane's back, up to her toes. Jump to the ball.**
- Include other review letters as needed by your students.

Stretch and Count/Stretch and Spell

- Call out a word, and ask students to break it down as they count the number of sounds in the word on their fingers. Ask them to draw a line for each sound that is represented in the word. Say the sounds in the word again, and have students write the letters that make the sound on the lines to spell the word.

yet

shut

- Collect the Partner Practice Booklets.

Emergent Reading

Story Review

- Briefly review the concepts-of-print book *At the Market*.
- Review the focus skills.

Remember that we have two word-wall words in this story. Point to “the” and “you” on the word wall, and ask students to read them. **We can use the sounds that we know and the pictures to help us read the other words.**

Partner Reading

- Distribute a book to each student.
- Have students read the story with their partners, alternating pages. When they finish, they should switch parts and read the story again.



Invite students to sing “March to Math” to signal that it is time for Math Mysteries.

Math Mysteries

TIMING GOAL: 25 minutes

Show What You Know



- Show the Ten-Frame Cards for 7 and 9. Use the sharing sticks to select students to identify which one is more and how they know. Repeat with the numbers 2 and 8. Award pocket points if students are able to identify the set that is more for each pair of numbers.
- Show the Ten-Frame Card for the number 6. Ask students to show you a set that is more using their fingers.



Active Instruction

- Explain that less is the opposite of more. Tell students that today they will learn about numbers that are less than other numbers.

Now that you understand more, we are going to learn about less. Less is the opposite of more. Ask students to repeat this with you.

- Point out that there are still two circles on the floor.

We are going to use circles on the floor again to compare groups. When we compared groups the last time, we were looking for the group that had more. This time we will look for the group that has less.

- Select five students to move into one of the circles.



WGR: How many students are in this circle? Count with me.

- Select seven different students to move into the second circle.

WGR: How many students are in this circle? Count with me.

- Ask students to identify the group that has less.



T-P-S: One of these groups has less students in it. Which one has less?

How do you know? *The group with five students has less. 5 is less than 7.*

You can look and see that there are less students in the group with five students.

- Explain that one group has less students in it than the other. Show the Ten-Frame Cards for the numbers 7 and 5. Point out that the Ten-Frame Card for the number 5 has less dots than the Ten-Frame Card for the number 7, just like the group with five students has less students than the circle with seven students.
- Ask the students in the circles to return to where they were sitting. Call on eight different students to move into one circle and six other students to move into the other circle.

T-P-S: Which group has less students? How do you know? *The group with six students has less than the group with eight students. You can see that there are less students.*

- Hold up the appropriate Ten-Frame Cards to reinforce which group has more. Continue with varying sets of numbers until all students have had an opportunity to have a clear understanding of less.

Partner Practice

- Give each student a Circle Workmat and a bag of twelve linking cubes. Give each partnership a set of Ten-Frame Cards for the numbers 2–10.

Now you are going to use cubes to make sets that are less than the numbers shown on the Ten-Frame Cards on your Circle Workmats.

- Show the Ten-Frame Card for the number 9. Ask students to make a set that is less than nine on their Circle Workmats. Point out that not everyone has the same number of cubes on his or her workmat, but everyone made a set that is less than nine.

You and your partner will take turns choosing a Ten-Frame Card. Then you will each build a set that is less than that number on your Circle Workmat, like we just did. You and your partner may have the same number of cubes, or you may not. You will count your partner's cubes to make sure that his or her set is less than the number on the Ten-Frame Card. Once you have checked each other's sets, you can clear your workmat and start over again.

- Model this activity if necessary.
- Circulate as students work. Encourage students to count their partners' cubes to check that their sets are less than the number on the selected card. Note any students who have difficulty with the concept of less.

Recap



- Show the Ten-Frame Card for the number 8, and ask students to make a set that is less than eight. Award pocket points if several students are able to successfully create a set that is less than eight.
- Play the “Scooter Counting Paintings” video to reinforce the concept of less.
- Review the concept of more.

T-P-S: How can we tell if one set has less than another set?

RWE: We can count the sets to see which one has less. We can look at them to see which set may have less. We can put the cubes together and put them side by side to see which set has less.

Sing “It’s time to go to sleep. It’s time to count our sheep.” Then count in a quiet voice, touch each student lightly on the head, and send them to retrieve their nap-time supplies.

Let's Daydream

TIMING GOAL: 25 minutes

Routine

1. Have students get out their supplies (towels, cots, etc.) for nap time.
2. Read the selected poetry, and play soft music (optional) as students rest.
3. Allow students to quietly look at another book during this time if they prefer.

Recommended Poetry Selection

- “Cats,” *The 20th Century Children's Poetry Treasury*, page 51

Introduce the Poem

Today I'd like to read you a poem about cats and where they like to sleep.



Gather students in a place where you will model during Write Away.

Write Away

TIMING GOAL: 20 minutes

Prewriting

- Present the writing topic for the day, and encourage students to share their ideas. To discourage copying later, do not write the ideas on the board.

Today we have been talking about how foods are sorted into categories at the market. You are going to write about the things you would find at a market.



What do you find in a market?

- Share an example that applies to you.

I think that I will write a sentence that says, “Fruit and bread are at the market.”

- Review previously introduced emergent-writing strategies.

T-P-S: What are some things that I can do if I don't know how to write some of the words in my sentence? *Draw a picture, draw a line, write sounds that I know, copy a word, and remember a word.*

I will use these things to write my sentence. You can use them when you write your sentence too.

- Use previously introduced writing strategies to model writing your sentence.

First, count the words on your fingers as you say the sentence again. Then, draw lines on the board to represent each word.

Example:

I am ready to write my sentence. My sentence is, “Fruit and bread are at the market.”

- **The first word is “fruit.” I hear a few sounds that we've learned in “fruit.” I hear /f/, /r/, and /t/. Write each letter on the first line as you say the sound.**
- **The next word is “and.” What sounds do you hear in “and”?** Repeat the word slowly. Write any letters that students say. If students say all the letters in the word, celebrate.
- **“Bread.” I think I will draw a loaf of bread for that word. Draw a loaf of bread.**

- **“Fruit and bread are at the market.” “Are” is the next word. I remember how to write that word.** Write “are.”
 - **“At.” I hear the /a/ and /t/ sounds in “at.”** Write “a” and “t.” **Look! I was able to write the whole word using sounds that I know!**
 - **“The” is the next word. It is on the word wall. I will copy it.** Write “the.”
 - **The last word is “market.” What sounds do you hear in “market”?** Say the word slowly, emphasizing the individual sounds. Write any letters that students say on the last line.
- Reread your sentence, touching each word, or word representation, as you do.

Partner Planning

- Ask students to share what they would like to write with their partners. Encourage them to use the Say-It-Back strategy to show their partners that they are listening.
- Monitor students, and listen to their discussions. Ask one or two students what their partners are planning to write.

Writing

- Distribute pencils and either writing journals or paper.
- Monitor students as they write. Encourage them to use the writing strategies that you have introduced as needed.
- Hold a writing conference with a few students as time permits. On the weekly record form, record the stage of writing that you observe for each of these students.

Sharing



- Ask students to share their sentences with their partners.
- Use the sharing sticks to select one or two students to share their writing with the class. Acknowledge and celebrate any emergent-writing strategies that they have used.



Invite students to recite or sing “Let’s Think About It” as they move to the gathering area.



Let's Think About It

TIMING GOAL: 20 minutes

Theme-Learning Recap



tps

- Review the learning focus of the day.

Let's think about our KinderCorner Market in the dramatic play lab.

WGR: How did you sort the food in the market during our morning group time? Into departments. Yes, you sorted the food into departments.

T-P-S: Why is food sorted into departments at the market? RWE: When food is sorted into departments, the food is easier for customers and store workers to find. Customers know to go to the dairy department for cheese and to the produce department for apples.

rwe

- Distribute one paper bag to each partnership. Explain the following game.

Let's play a game with the foods in our market. You'll work with your partner to gather the foods. I'm going to name a department in our market, and you'll take turns spinning the Grocery Store Spinner and gathering that number of food items from that department. Let's do one together.

- Have a student spin the spinner. Have that student and his or her partner gather that number of food items from the produce (meat, dairy, etc.) department in the KinderCorner Market and bring them back to the group.
- Have all students count the number of items in the bag to be sure that the number of items matches the number on the spinner. If the number of items is different from the number on the spinner, ask what needs to be done to make them the same. Have students return their items to the correct department while another partnership takes a turn spinning the spinner and gathering groceries from a different department.
- If you were able to arrange a field trip to a grocery store, you might like to take this time to write a class thank-you letter to the store. Encourage students to share what they enjoyed about the store or what they learned that was new.



Vocabulary Review

- Briefly review the new theme-related vocabulary words. Use My Turn, Your Turn to have students practice saying each word. Then provide a brief definition, and make connections to the contexts in which the word was used today.

tps

One of our new words today is "customer." A customer is a person who buys something from a store or restaurant. T-P-S: When did we see, hear, or use the word "customer" today?

Our other new word today is "department." Markets are divided into departments. When did we see, hear, or use the word "department" today?



- Ask partners to work together to think of a sentence that uses one of the words. Use the sharing sticks to select a student to share the sentence with the class. Use the Oral-Language Scoring Rubric to score the response. Record the score on the weekly record form.

| Oral-Language Scoring Rubric | |
|------------------------------|---------------------------------------------------------------------------------------|
| 70 | The student does not respond, or the response does not make sense. |
| 80 | The student responds with a word or phrase that makes sense. |
| 90 | The student responds in a complete sentence that makes sense. |
| 100 | The student responds in a complete sentence(s) that makes sense and includes details. |

- Use the suggestions below to help foster oral-language development.

Theme Vocabulary:

customer
department

| Fostering Richer Language | | |
|-------------------------------------------------------------------------------------------------------------------|------------------------------------------------------------------------------------------------------------------------------------------|------------------------------------------------------------------------------------------------------------------------------------------------------------------------------------------|
| Student Response | Teacher Prompt | Further Prompting |
| The student responds in an incomplete sentence. Store departments. | Good answer. Can you say that in a complete sentence? | If the student is unable to respond in a sentence, model a sentence for him or her. <i>We can say, The store has departments.</i> |
| The student responds in a complete, but not very elaborate, sentence. The store has a dairy department. | You made a complete sentence with the word. Can you add some details to your sentence? OR Can you tell us a little more about the _____? | If the student is unable to add details, prompt with a question about the sentence. Can you tell us more about the kinds of foods that you would find in the dairy department? |



- Award pocket points if the student is able to create a complete sentence.

Partner Challenge

- Review the Partner Challenge of the day.

We have one more opportunity to earn pocket points today! Let's review our Partner Challenge. Our Partner Challenge today is to tell your partner why it was important for Joey to use Stop and Stay Cool. Allow students time to review what they told their partners earlier in the day.



- Use the sharing sticks to select students to share their responses. If you feel your students are able, have them tell their partners' responses. Award pocket points when you observe students using active-listening skills when working with their partners.
- Invite students to compliment the Cool Kid for successfully demonstrating Getting Along Together skills.

Pocket Points for the Day

- Empty the chips from KinderRoo's pouch, and encourage students to join you in counting them.
- Pour the chips into the jar, and observe how close the total is to the reward line.
- Remind students about their reward.

Home Link/Departure

- Invite students to tell their partners one thing that they did or learned today at school.
- Make any announcements or give reminders (upcoming field trips, picture day, etc.).
- Remind students to watch tonight's Home Link show. Tell students to click on the walrus for today's show.
- **Read & Respond: Share a book with someone in your family. Ask him or her to sign your Read & Respond bookmark.**
- Use the walrus stamp to place an animal image on each student's hand.

Day 8 | Ready, Set...

Focus

Markets are in every country in the world.

| Additional Materials Needed Today | |
|--------------------------------------------|-----------------------------------------------------------------------------------------------------------------------------------------------------------------------------------------------------------------------------------------------------------------------------------------------------------------------------------------------------------------------------------------------------------------------------------------------------------------------------------------------------------------------------------------------------------------------------------------------------------------------------------------------------------------------|
| Greetings, Readings, & Writings | <ul style="list-style-type: none"> Literacy Lab: Key card for “y” Math Lab: Linking cubes or counters |
| Gathering Circle | <ul style="list-style-type: none"> Joey and Alex puppets Joey and Alex stick puppets (one set per partnership) |
| Theme Exploration | <ul style="list-style-type: none"> Map of the world or globe Images of several different types of bread, including sliced bread, a hamburger bun, a baguette, naan (optional) Theme vocabulary word card for “country” or IWB access |
| Rhyme Time | <ul style="list-style-type: none"> KinderCorner 2nd Edition Plus Media and Software flash drive |
| STaR | <ul style="list-style-type: none"> <i>Tap-Tap</i> Globe or map (optional) |
| 15-Minute Math | <ul style="list-style-type: none"> Number-Recognition Circle 1–5 Number-Recognition Circle 6–10 Two More and Two Less poster Clothespin Overhead marker |
| Snack/Outside/ Gross-Motor Play | <ul style="list-style-type: none"> A variety of breads that represent different cultures (optional) One or two spreads |
| Stepping Stones | <ul style="list-style-type: none"> Key card for “q” or IWB access “Qq” Uppercase and Lowercase Letter Card Letter-Blending Cards (“qu,” “i,” “y,” “t,” “u,” “m”) or IWB access KinderRoo puppet /q/ picture cards (quarter, quilt) or IWB access Common /q/ objects (optional) Stepping Stones Partner Practice Booklets for unit 6 Individual writing boards and writing implements (or pencils if writing in the Partner Practice Booklets) KinderCorner 2nd Edition Plus Media and Software flash drive Concepts-of-print book (student copies): <i>Lunch Time</i> |

| Additional Materials Needed Today | |
|-----------------------------------|------------------------------------------------------------------------------------------------------------------------------------------------------------------------------------------------------------------------------------------------------------------------------------------------------------------------------------------------------------------------------------------------------------------------|
| Math Mysteries | <ul style="list-style-type: none"> • Ten-Frame Cards 1–10, one set • Linking cubes: six blue, three red, nine green • Ten-Frame Workmat (appendix), one per student • Small plastic bags of twelve linking cubes each, one per student • 2–9 Spinner (appendix) • More-or-Less Spinner (appendix), one for the teacher • Two transparent spinners |
| Let's Daydream | <ul style="list-style-type: none"> • “For Sale,” <i>The 20th Century Children's Poetry Treasury</i>, page 20 |
| Write Away | <ul style="list-style-type: none"> • Trade book: <i>More Spaghetti, I Say!</i> |
| Let's Think About It | <ul style="list-style-type: none"> • Index cards for letters that begin the names of common supermarket products, one per partnership • Number Cards 1–10, one per partnership • Map or globe • Home Link animal hand stamp: hippopotamus |

Learning Labs—Additional Materials

| |
|-------------------------------------------------------------------------------------------------------------------------------------------------------------------------------------------------|
| Literacy Lab Play School: Yellow Yo-Yo |
| <ul style="list-style-type: none"> • Glue • Yellow Yo-Yo “y” Pattern sheet (appendix) • Key card for “y” • Yellow yarn precut to fit the “y” patterns |
| Science Lab Which Weighs More? |
| <ul style="list-style-type: none"> • Balance scale • Items to be weighed (fruits, vegetables, classroom objects) |

Day 8

Greetings, Readings,
& Writings

TIMING GOAL: 15 minutes

| Student Routines | Teacher Routines |
|-------------------------------------------------------------------------------------------------------------------------------------------------------------------------|----------------------------------------------------------------------------------------------------------------------------------------------------------------------------------------------------------------------------------------------------------------------------------------------------------------------------------------------------------------------------------------------------------------------------------------------------------|
| <ol style="list-style-type: none"> 1. Remove coats and backpacks. 2. Turn in homework. 3. Sign in. 4. Self-select activities. | <ol style="list-style-type: none"> 1. Greet parents and students. 2. Remind students to read the Arrival Activities poster as they prepare for their day. 3. Encourage students to describe what they are doing in full sentences as you observe their activities. 4. Observe for student progress with their individualized objectives from the weekly record form. Circle demonstrated skills if applicable. |

Homework

- Read & Respond

Facilitate Learning

As you greet students this morning, welcome them using words from languages spoken around the world, such as “¡hola!,” “shalom,” “bonjour,” “konnichiwa,” and “jambo.”

Available Activities

Classroom Library Lab

- Same as day 7

Literacy Lab

- Add the key card for “y” to the lab. Encourage students to use the tactile letter-formation materials to practice forming the shape of /y/.

Math Lab

- Encourage students to use the materials to make sets that are less than a given number.

Computer/Media Lab

- Same as day 7

Writing Lab

- Same as day 7

Other

- If you have any theme-related puzzles or games, make them available.



Sing a transitional gathering song. Encourage students to sing along as they move to the gathering area.

Gathering Circle

TIMING GOAL: 20 minutes

Routine

1. Welcome students to the Gathering Circle.
2. Check attendance.
3. Discuss yesterday's homework assignment. Award pocket points if at least half the students completed their homework.
4. Remind students about the responsibilities associated with each classroom job as needed.
5. Make sure that students are sitting with their partners for the week.
6. Select this week's second Cool Kid.

Home Link Debrief



- Invite children to share what they remember from last night's Home Link show.
TP-S: Last night's song was "The Crabfish Song." How did you dance to this song?



- Use the sharing sticks to select two or three children to share their dance moves with the whole class. Award pocket points in recognition of students' efforts.

Active Instruction

- Have students say the Stop and Stay Cool rhyme (see day 3) to review the Stop and Stay Cool steps.
- Review yesterday's lesson activities.

We've learned how to use Stop and Stay Cool when we are upset or angry. Yesterday we saw that Joey was angry with Alex. We helped Joey use the steps of Stop and Stay Cool when he was angry so he could calm down.

- Quickly review the scenario from day 7.

As Joey: **Alex, hand me the red marker.**

As Alex: **No.**

As Joey, in an upset voice:
Alex, you're not even using the marker.

As Alex: **I'm not using it now, but I may need it later.**

As Joey, getting angry, shaking:
That's not fair! Give it to me!

As Alex: **I said no. Now leave me alone. You're bothering me.**

As Joey: **Alex, you're mean. I am so angry right now that I don't want to be your friend anymore!**

T-P-S: What happened to make Joey so angry? How did we help Joey calm down?

Partner Practice

- Students will create a scenario in which puppets have to use Stop and Stay Cool.
- Distribute a set of paper Joey and Alex puppets to each partnership.

Today you will make up a little play with your puppets in which one of them gets angry or upset and needs to calm down before he loses control. Then we will help your puppet calm down using the steps for Stop and Stay Cool.

- Brainstorm several scenarios with students. Have them select one and use their puppets to act it out. If students have difficulty with brainstorming conflict situations, you may want to offer the following scenarios from which they may choose. More than one partnership may choose the same scenario.
 - One character takes something from the other and won't give it back.
 - One character knocks down the other's block tower.
 - One character pushes the other to get in the front of the line.
 - One character wants to sit with a friend, but the other is already there and won't move.
 - One character wants a turn doing a class job that the other won't give up.
- Provide students with time to think about their scenarios and to develop short skits.

Partner Challenge

- Explain the challenge.

Today your challenge is to act out your puppet skit with your partner. Be sure to show why one of the puppets is angry and all the Stop and Stay Cool steps.

- This afternoon we will select some of you to share your puppet skits with the class.
- Provide a few minutes of practice time if you have not already done so.

Theme Exploration

TIMING GOAL: 15 minutes

Partnership Question of the Day



T-P-S: **Do people all around the world eat the same food?**

Let's see what our Daily Message says about markets and food today.

Daily Message

Markets are in every country in the world.



- Write the Daily Message in front of students, reading each word as you finish writing it. Then read the entire message again, touching each word as you read it.
- Reinforce literacy objectives by pointing out the following:
 - **I see a word from our word wall in the Daily Message! WGR: What word do you know from our word wall? "The."** Circle the word "the."
 - Use Stretch and Read to have students read the word "in."
 - **How many times does the word "in" appear in our Daily Message? Two times.** Underline both occurrences of "in."

Theme Learning



- Explain the content of the Daily Message.

Our Daily Message tells us that markets are in every country in the world. Point out your country on the map or globe. This is our country. This is where we live. Do we have food markets in this country? Yes! Point to and name several places around the world. Name countries where students might have come from or where they might have family living. There are markets in each of these countries too. No matter where you go in the world, you will find places to buy food.
- Briefly review the departments added to the KinderCorner Market yesterday.
- Draw connections between the departments in American grocery stores to those in markets elsewhere in the world.

Many of the markets throughout the world are divided like our grocery store. They have dairy, bakery, produce, and meat departments. If you look closer, though, the food inside these departments changes from country to country. In our country, we often see loaves of bread that have been sliced in our bread aisle. We also see buns and rolls for sandwiches. Point to France on your map. In France, a different type of bread is more popular. French bread, or "baguettes," are long, thin

crispy loaves of bread that are not sliced. Point to India on your map. In some Middle Eastern and Asian countries, flat bread called “naan” is popular to eat with meals. Bread is sold in markets all around the world, but not every country has the same kind of bread.

- Remind students of the way that you greeted them this morning.

When you arrived at school this morning, you may have heard me say some funny words. Listen as I say each of the words again. Wave hello as you say each of the following words: “¡hola!,” “shalom,” “bonjour,” “konnichiwa,” “jambo.”



I just said the same word in five different languages. T-P-S: Do you know what word I just said to you? RWE: I said “hello!” in Spanish, Hebrew, French, Japanese, and Swahili.

- Point out Mexico, Spain, or other Spanish-speaking countries that your students may have ties to, and teach students to say “¡hola!”
- Point out France or other French-speaking countries that your students may have ties to and teach students to say “bonjour!”
- Continue this process for Israel, Japan, and east African countries such as Kenya, Uganda, and Tanzania.
- Invite students who speak other languages to teach their classmates how to say “hello” in their languages. Assist these students in locating countries where these languages are natively spoken on the map or globe.
- Encourage students to use these phrases as they greet one another throughout the day, especially during Learning Labs.
- Play the digital dictionary video for “country.”
- Re-emphasize the theme-related vocabulary word. Post the word, or point to it on the interactive whiteboard, as you discuss it.



Our new word for today is “country.”

The world is divided into countries. A country is an area of land where many people live. One person or group of people rules each country. I can make a sentence with the word “country.”

The United States of America is one of the largest countries in the world.



Ask students to stand up as they sing “It’s Time for a Rhyme” to signal the transition to Rhyme Time.

Rhyme Time

TIMING GOAL: 5 minutes

Say the Rhyme

- Have students recite “Food for You and Me.” Encourage them to do the physical motions that accompany the rhyme.
- Read the words (see day 6), or play the video.



Develop Phonemic Awareness—Auditory Sound Segmenting

- Ask students to listen carefully to the following words. After you say each word, have them break it down to say each word in Joey Talk.

| | | | | | |
|------------|---------|-------------|----------|------------|---------|
| cut | /c-u-t/ | food | /f-oo-d/ | big | /b-i-g/ |
|------------|---------|-------------|----------|------------|---------|



- Award pocket points if students are able to successfully produce the sounds in each word.



TRANSITION

Sing the song “Let’s Read Together” with students.

STaR Interactive Story Reading

TIMING GOAL: 20 minutes

STaR Words:

ached
stack
journey

Tap-Tap

Written by Karen Lynn Williams

Illustrated by Catherine Stock

At eight years old, Sasifi is now old enough to help her mama sell their oranges at the market. It is hard work carrying the basket of fruit on her head, and Sasifi wishes to ride the Tap-Tap. After working all day at the market and selling all the oranges, she is rewarded with some coins to buy herself a treat. There are many things from which to choose, but Sasifi uses her money to treat herself and her mama to a ride home.

Interactive Story Reading

Before Reading

- Introduce the title, author, and illustrator of the story. Have students identify the author’s and illustrator’s roles and the purpose of the title.



The title of today’s story is *Tap-Tap*. WGR: **What does the title of a story tell us?** *The name of the story.* **The author is Karen Lynn Williams.** Invite students to jump right in to complete the following sentence. **The author [writes the words] of a story.** WGR: **What does the illustrator do?** *Makes the pictures.* **The illustrator of *Tap-Tap* is Catherine Stock.**

- Have students preview the story. Guide them as they make predictions about the story based on the cover illustration and the title.

This story takes place in an island country called Haiti. Show students the location of Haiti on the globe (or map). In Haiti, the bus that takes people back and forth to places they need to go is called a tap-tap. A tap-tap is like a taxicab or a commuter bus. The title of the story is just *Tap-Tap*, the word for the bus. That doesn't tell us much about the story.



Point to the girl on the cover. Think aloud, **It looks like this girl is running. I wonder if she is running to get on the tap-tap to take a ride somewhere.**
T-P-S: **What do you see in the illustration that makes you wonder about what will happen in this story?**

When we listen to the story, we will find out if your ideas are in here.

- Introduce the story vocabulary words.

There are many interesting and new words in this story. One new word you will hear is “ached.” “Ached” means hurt. We heard about another kind of ache in the story *The Very Hungry Caterpillar*. WGR: What kind of ache did the caterpillar have after he ate too much food? *Stomachache*. In today's story, we will find out why the main character Sasifi's neck ached.

In this story, Sasifi and her mother go on a journey. A journey is a long trip. T-P-S: Have you ever taken a journey? Tell your partner about a long trip you took.

Another word you will hear today is “stack.” When you stack things, you place them in a neat pile. What is something we stack in our classroom to keep them neat? *Papers, blocks, books, etc.*

- Introduce the good-reader skill for today.

As they read a story, good readers think about what has happened so far. We will stop a few times during the story today and think about what has happened so far.



Summarization

During Reading

- Use Think-Pair-Share or Whole-Group Response to engage students in an ongoing discussion about the story as guided by the questions and comments below.
 - **Page 3: T-P-S: Why does Sasifi want to ride in a tap-tap?** If someone mentions that Sasifi wants to ride the tap-tap because her neck ached, point out that “ached” is a new word that means her neck hurt.
 - **Page 7: Sasifi sees many things that people sell in the market. One man has a stack of hats for sale. “Stack” is one of our new words. The man has the pretty straw hats piled up neatly for people to buy. T-P-S: What else does Sasifi see at the market?**
 - **Page 12: Let's think about what happened in the story so far. T-P-S: Why do Sasifi and her mother go to the market? What do they do when they get there? Sasifi works hard to help her mother take their oranges to the market and sell them. How does Sasifi's mother show her that she thinks Sasifi did a good job selling the oranges? Restate students' responses to summarize the story up to this point.**



- **Page 15:** T-P-S: What does Sasifi decide to do with the money her mother gives her for her hard work?
- **Page 24:** The first part of the story is about Sasifi and her mother going to the market and what happens when they get there. Let's think about what happens when Sasifi decides to use her money to ride the tap-tap home. T-P-S: Why doesn't the tap-tap driver take Sasifi and her mother home when she says they're ready? Who else gets on the tap-tap? When does the tap-tap finally move?
- **Page 27:** T-P-S: How do the man with the hats, the woman with the chickens, and the man with the chairs let the driver know that they want to get off?
- **Page 30:** Sasifi tries to tell people on the tap-tap that she lost her hat, but no one hears her. T-P-S: What do you think Sasifi can do so she can get her hat?
- **Page 34:** Let's think about what happens at the end of the story. As the tap-tap drives along, people bang the side of the truck so the driver will stop. T-P-S: What happens when the tap-tap stops? People get off. Sasifi loses her hat. How does she get it back? She bangs the side of the truck. How does Sasifi feel when she gets off the tap-tap?

After Reading



T-P-S: What kinds of things are sold at the market that Sasifi and her mother go to? What kinds of things are sold at the market where you and your family shop?

T-P-S: Does Sasifi's market in Haiti look like the market where you shop? How is it the same? How is it different?

- Make summative statements about the story that reinforce the STaR vocabulary. Guide students to make sentences with the words.

Sasifi and her mother walk in the hot sun carrying baskets of oranges on their heads to the market. This makes Sasifi tired. I remember that her neck ached when she was walking. "Ached" is one of our new words. Let's make a sentence using the word "ached." T-P-S: Talk to your partner about ideas that you have for our sentence.

- Use students' ideas to develop a sentence. Write the sentence on the board in front of students, saying each word as you write it. Repeat with the words "journey" and "stack."



Use the 1-2-3 Move signal to move students from the STaR area to the dramatic play lab for the beginning of the lab tour.



TIMING GOAL: 40 minutes

Routine

1. Have a lab tour to explain the activities or materials in any new labs.
2. Guide students as they select the lab that they will visit. Use the lab-management system to ensure that not too many students plan to visit the same lab at the same time.
3. Students will complete their Learning Lab plan. Conference with as many students as possible about their writing before they are dismissed to labs.
 - Write the code for the writing stage exhibited by the student in the top right-hand corner of the student's paper.
 - Use the methods described in the *Writing Development Feedback Guide* to provide feedback.
4. Monitor students as they visit their selected labs.

Dramatic Play Lab | KinderCorner Market

Description:

- The dramatic play lab will continue to be a market.

When You Tour:

- Remind students that the lab is a market today. Ask students how markets in other countries might be different from markets in the United States.

Blocks Lab | Off to the Market

Description:

- Students will continue to use trucks to deliver fruits and vegetables to the market.

Purpose:

- Remind students that they can deliver fruits and vegetables to the market.

Art Lab | Shopping Bags

Description:

- Students will continue to decorate shopping bags for the KinderCorner Market.

When You Tour:

- Remind students that they can decorate shopping bags for the KinderCorner Market.

Classroom Library Lab | Free Reading

Description:

- Students will continue to explore books independently or with a friend.

When You Tour:

- Remind students that they can explore books independently or with a friend.

Literacy Lab | Play School: Yellow Yo-Yo

Description:

- Students will use materials commonly found in classrooms to play school. In their imaginary classroom today, students will glue yellow yarn to the /y/ yo-yo outline.

Purpose:

- This lab helps students to develop fine-motor skills and reinforces letter shapes and sounds.

When You Tour:

- Tell students that today in their imaginary classroom they can glue yellow yarn to the yo-yo outline.
- Present the “y” key card. Have students practice with you the sound and letter formation using the cue, Slant right down one string and way down the other— /y/, /y/, /y/.

Facilitate Learning:

- Join students, and make your own yellow yo-yo.
- Encourage students to squeeze the glue onto the yo-yo outline in the shape of “y” before gluing the yellow yarn in the same shape. Invite students to trace the yellow yarn yo-yo “y” with their fingers, to press it firmly onto the glue, and to have further tactile experiences with the letter shape. They could also trace “y”s in the sand or feel magnetic letter “y”s.
- Engage students in practicing the letter cue as they form or trace the shape.

Math Lab | The Right Price

Description:

- Students will create price tags for the food items in the KinderCorner Market.

When You Tour:

- Let students know that the lab is open today. Remind them that they can get supplies from the writing or art labs, if necessary, for their price tags. They may also bring their price tags to the KinderCorner Market when they are finished.

Computer/Media Lab | Free Exploration

Description:

- Students will continue to explore educational software or listen to music with computers, CD players, or other digital devices.

When You Tour:

- Remind students that the lab is open today.

Sand/Water Lab | Fill 'er Up

Description:

- Students will continue to fill up various containers with water and sand.

When You Tour:

- Remind students that they can fill up various containers with water and sand.

Science Lab | Which Weighs More?

Description:

- Students will use a scale to compare the weights of various objects.

Purpose:

- This lab provides students with opportunities to weigh, predict, estimate, and record.

When You Tour:

- Tell students they will weigh various objects.
- Point out the balance scale, and ask students if they know what it is used for.
Compares items to see which is heavier or lighter.
- Ask, **Where have you seen other kinds of scales?** *Grocery store, home, doctor's office.*
- Explain, **The scale in the store tells how much something weighs so we know how much to pay for the item. A balance scale compares the weights of two items. It shows which of the two items is heavier or lighter.**
- If you have fresh vegetables and other foods available, tell students that they may place the foods on the balance scale to compare their weights.
- Encourage them to record the results.

Facilitate Learning:

- As students use the balance scale to compare weights, reinforce the use of comparative words such as “more than” (heavier), “less than” (lighter), and “equal to” (the same as).
- Help students observe that it takes several lighter objects to equal one heavier one. Encourage students to predict which pieces of fruit or other foods will be heavier or lighter than others.

Writing Lab | Make a List, Please

Description:

- Students will continue to write grocery lists.

When You Tour:

- Remind students that they can make grocery lists. Suggest that students pretend to make a grocery list for a market in another country. What would be on the list?



Provide five-minute and three-minute warnings before the end of the labs. Then sing the clean-up song to prompt students to put away the lab items and move to the 15-Minute Math board.



15-Minute Math

TIMING GOAL: 15 minutes

Complete the following activities as described on day 1.

Calendar

- Before placing the calendar cutouts on the calendar, ask students to look at the pictures on the cutouts. Point to the pictures as you name them. Ask students to think about which picture will be on the next cutout. Add the calendar cutout for today's date to the calendar, and ask, **Is this the picture you thought it would be? Replies. How did you know which picture would be next? The pictures make a pattern, and patterns repeat.** Point to the calendar again, and say, **Today is** (day of the week), (month and date).

Days of the Week

Days of School Tape

Ten-Frames

Hundreds Chart

Two More and Two Less

- Ask students if they notice anything new on the board. Point to the poster, and explain that they will be finding numbers that are two more and two less than a particular number. Select a student to clip the clothespin on any number on the 1–5 or 6–10 number-recognition circles. Using the overhead marker, record this number in the middle column on the poster. Then have students identify two more and two less than the number. Record these numbers in the appropriate columns on the poster.

This activity will have students determine two more and two less than a given number.



Recite the Stop and Stay Cool rhyme as students move to the area where you will serve the snack.



Snack • Outside • Gross-Motor Play

TIMING GOAL: 30 minutes

Snack

- Serve a variety of breads that represent different cultures such as pita, tortillas, bagels, and pretzels. Students may choose which type of bread they would like to try. Talk with them about why this food is a good choice for them and how it helps them to grow. Talk with them about how markets in different parts of the world all sell some sort of bread. Encourage students to use new vocabulary by naming the type of bread that is tasted.
- Invite students to talk about the Partner Challenge. **Your Partner Challenge is to act out a puppet skit with your partner. Your skit should show why one of the puppets is angry. It should also show all the Stop and Stay Cool steps.**
- Award pocket points if students include showing why one of the puppets is angry and demonstrate all the steps.



Outside/Gross-Motor Play

- For those students needing or wanting structured activities, repeat one or more of the circle games that was introduced earlier in this unit. Encourage students to take turns leading the various games.



When students come back inside, select one student to play teacher. As students return to the gathering area for Stepping Stones, that student will point to each word on the word wall for the other students to read.



Stepping Stones

TIMING GOAL: 30 minutes



Beginning Phonics: /q/ – a bounced sound

Review

- Have students name each mnemonic picture as you point to it on the wall frieze.
- Ask students to provide the sounds for letters that have already been introduced with uppercase and lowercase cards attached.
- Show the Animated Alphabet segment for /y/.



Introduce the New Sound

Silly Sentence

- Present the KinderRoo puppet. Explain that she has a new sound for them to learn—a sound that they will hear in the silly sentence she has brought.
- Say the alliterative phrase two or three times, emphasizing the /q/ sound at the beginning of each word by softly bouncing it.

The queen is quite quiet.



- Use Think-Pair-Share to ask, **What sound do you hear at the beginning of “queen,” “quite,” and “quiet”?**
- Explain that the /q/ is a bounced sound. When we say it, we want to be careful to say it softly and quickly, like the motion of a bouncing ball. We have to be careful not to say /kwuh/.



- Use My Turn, Your Turn to have students repeat each of the words that begin with /q/, softly bouncing the /q/ sound at the beginning of each word.

Let's practice that sound.

Teacher: /q/ ueen

Students: /q/ ueen

Teacher: /q/ uite

Students: /q/ uite

Teacher: /q/ uiet

Students: /q/ uiet

Mnemonic Picture

- Show the picture side of the key card for “q.” Explain that the picture we have to help us remember the sound /q/ is a queen.



Let's watch our funny cartoon about /q/. It will help us to remember the sound.

- Play the Animated Alphabet segment for /q/. Point out that the baby sitting in the queen's lap makes the /q/ sound as it cries.

People, Pictures, and Objects

- Have KinderRoo help you identify any students whose names begin with /q/. Explain that KinderRoo has brought some pictures and objects that begin with /q/. Say the name of each picture or object as you present it, and emphasize the /q/ sound.

quarter

quilt

- Ask students to name each picture or object as you point to it. Ask, **What sound do you hear at the beginning of _____?** as they name each one.



Making the Sound

- Ask students to think about what is happening in their mouths as they make the /q/ sound.

When I say /q...q...q/, my mouth is making two sounds. I hear /k/ at the beginning. Then I hear /w/ at the end. This is a two-part sound. /q...q...q/. Let's bounce the sound together. /q...q...q/.

- Have them face their partners and make the sound several times as you ask the following questions:
 - **Is your mouth open or closed when you make the sound?**
 - **What is your tongue doing when you make the sound?**
 - **Gently touch your throat. Can you feel a vibration when you make the sound?**

Compare Uppercase and Lowercase

- Use the Uppercase and Lowercase Letter Cards to show students what both forms of the letter look like.
- Attach the uppercase and lowercase card next to the corresponding mnemonic picture on the wall frieze.



How are the two letter shapes the same? How are they different?

Partner Practice

Reading Sounds

- Distribute the Partner Practice Booklets and a crayon or pencil to each student. Ask students to open their booklets to page 10. Encourage partners to help each other find the page. Have the partners work together to read the sounds.
 - Jelly will point to the sounds, and Peanut Butter will read them. Jelly will help as needed.
 - After Peanut Butter has finished reading the sounds, Jelly will write their initials in the box at the bottom of Peanut Butter's page.
 - Peanut Butter will point to the sounds, and Jelly will read them. Peanut Butter will help as needed.
 - After Jelly has finished reading, Peanut Butter will write their initials in the box at the bottom of Jelly's page.

Stretch and Read

- Explain that the sounds we have been learning to read can be put together to make words. Model the process by placing the letter cards for /qu/, /i/, and /t/ a few spaces apart in a pocket chart or along a chalkboard tray. Gradually move the letters closer together, and have students blend the sounds together with you until you say "quit." Repeat with the word "yum."

We know that words are made of sounds. We can read a word by saying all the sounds and blending them together. We call this Stretch and Read.

Alphie and his friends can use Stretch and Read to sound out words too. Let's watch.



- Show the Sound and the Furry video segment.

Now you will get to use Stretch and Read to read some words with your partner. The words you will read are different from the words we read together. Let's see who can figure out the words!

- Have students work with their partners to read the words in their Partner Practice Booklets using Stretch and Read.
- Use the sharing sticks to select a student to read the sounds for the class. Select another student to read the words. Provide assistance as needed. Award pocket points if they attempt to read all the sounds or words.



Forming the Letter

Introduce the shape of /q/.

- Explain that now you will show students how to write the letter that makes the /q/ sound. Trace the letter with your finger as you say the letter-writing cue “Left around the queen and way down her staff.” Ask students to say the cue with you two or three times as you trace the letter again.
- Show the letter-only side of the key card. Make a connection to the letter shape and the mnemonic picture.

Example:

- **What picture does this letter look like? Queen. Yes, this letter looks like a queen and her staff.**

Write /q/.

- Demonstrate writing the letter in front of students several times on a writing board or chart paper. Ask students to say the writing cue with you as you form the letter.
- Hold the picture side of the key card next to the letters you have written. Ask students whether your letters look like the queen. Place the key card in a pocket chart with the letter side facing outward.
- Guide students to practice forming the letter shape using their fingers as pencils several times in different ways (in the air, on the carpet, on their legs, etc.). Encourage them to say the cue as they write the letter.
- Distribute individual whiteboards and dry-erase markers, chalkboards and chalk, or paper and pencils or crayons. You may also use the space provided in the Partner Practice Booklet for writing. Ask students to write /q/ several times, reciting the cue with them each time.
- Ask students to examine their partners' letters for /q/ and circle the best one. Encourage them to tell their partners why they think it's the best.
- Have students write other letters that they have learned. Encourage them to say the cue as they write each letter.
 - /y/ **Slant right down one string and way down the other.**
 - /v/ **Down one wing and up the other.**
- Include other review letters as needed by your students.

Stretch and Count/Stretch and Spell

- Call out a word, and ask students to break it down as they count the number of sounds in the word on their fingers. Ask them to draw a line for each sound that is represented in the word. Say the sounds in the word again, and have students write the letters that make the sound on the lines to spell the word.

quit

yum

- Collect the Partner Practice Booklets.

Emergent Reading

Story Introduction

- Show the cover of *Lunch Time*. Introduce the title and author.

Today we will read a story about healthy foods that can be eaten at lunch time. We will see what the Kinderfriends like to eat for lunch. I wonder if they like to eat the same foods as you!

- Introduce the focus skills for the story.

There is a word from our word wall in this book. Let's review all the words. Quickly point to each word, and have students read them in unison. Point to the word "a." **We will see the word "a" on every page of our book.**

We can use the pictures and the first sounds of the food words to help us read the other words in our book.

- Read the book to students. Pause before you read each food word. Point to the picture and then the first letter, or letter group, in the word. Emphasize the initial sound as you read the word.

Guided Group Reading

- Distribute a book to each student. Read the book again, this time inviting students to read in unison with you as they follow along in their own books.



Invite students to sing "March to Math" to signal that it is time for Math Mysteries.



TIMING GOAL: 25 minutes

Show What You Know



- Show the Ten-Frame Cards for 3 and 6. Use the sharing sticks to select students to identify which card is less and how they know. Repeat with the numbers 7 and 9.

Award pocket points if students are able to identify the set that is less in each pair of numbers.



- Show the Ten-Frame Card for the number 5. Ask students to show you a set that is less using their fingers.

Active Instruction

- Remind students that more and less are opposites. Explain that today students will practice making sets of more and less.



T-P-S: More and less are opposites. What other opposites can you name?
Day and night, wet and dry, right and left, etc.

- Explain that today students will make sets that are more and less.
- Show the Ten-Frame Card for the number 6.



WGR: What number is this? 6. Count the dots with me.

- Make sure that students are seated in a circle or in a way that they can see the sets you are creating. Create a set of six blue linking cubes.

This set of cubes is the same number as the Ten-Frame Card I just showed you. There are six blue cubes. Now I am going to make a set that is more than six cubes and a set that is less than six cubes.

- Make another set of three red linking cubes and a set of nine green linking cubes.
- Ask students to identify the set that has more.

T-P-S: One of these sets has more cubes than the blue set that has six cubes. Which one is more? How do you know? *The set of green cubes has more than six cubes. You can see that there are more cubes. You can count the cubes to see that it has more.*

- Repeat by asking students to identify the set that has less.
- Continue in the same fashion by creating sets that are more than and less than three and asking students to identify the sets that are more than and less than three.

Partner Practice

- Give each student a Ten-Frame Workmat and twelve linking cubes. Show students the More-or-Less Spinner and the 2–9 Spinner. Explain the activity, and model if necessary.

Now you are going to work together to use cubes to make sets that are less than the number that I spin. First, I will spin the number spinner. One partner will use cubes to make that number on the Ten-Frame Workmat. Then, I will spin the More-or-Less Spinner to tell you whether the other partner will build a set that is more than or less than my number.

- Spin the 2–9 Spinner. Tell students which number the spinner lands on. Ask one partner to make a set equal to that number on the Ten-Frame Workmat. Then spin the More-or-Less Spinner. Tell the other partner to create a set that is more than or less than the number that his or her partner created.

If students have difficulty remembering the number that was spun, hold up or post the Ten-Frame Card for that number so students can see it.

- Ask partnerships to share the sets that they created. Point out that even though partners may have created different sets, they are still more than (or less than) the original number.
- Spin again, but this time ask partners to switch roles.
- Circulate as students work. Encourage students to count their partners' cubes to check that their sets are more or less than the number spun. Note any students who have difficulty with the concepts of more and less.
- Challenge students to figure out how many more or less cubes there are in the sets they create.

Recap

- Spin the 2–9 Spinner. Ask students to create a set that is more than the number you spun.
- Spin again, and ask students to create a set that is less than the number you spun.
- Award pocket points if several students are able to successfully create a set that is more than and a set that is less than a given number.
- Play the “Scooter More or Less” video.
- Review the concepts of more and less. Show the Ten-Frame Card for the number 4. Ask students to show you the answer using their fingers.



WGR: Show me a set that is more than four. Wait to see students' answers.
Now show me a set that is less than four.

- Point out that even though students made different sets, all the sets were more than or less than four.



TRANSITION

Sing “It’s time to go to sleep. It’s time to count our sheep.” Then count in a quiet voice, touch each student lightly on the head, and send them to retrieve their nap-time supplies.

Let's Daydream

TIMING GOAL: 25 minutes

Routine

1. Have students get out their supplies (towels, cots, etc.) for nap time.
2. Read the selected poetry, and play soft music (optional) as students rest.
3. Allow students to quietly look at another book during this time if they prefer.

Recommended Poetry Selection

- “For Sale,” *The 20th Century Children's Poetry Treasury*, page 20

Introduce the Poem

Here is a poem about someone who finds that a little sister can be a bother.



Gather students in a place where you will model during Write Away.



TIMING GOAL: 20 minutes

Prewriting

- Present the writing topic for the day, and encourage students to share their ideas. To discourage copying later, do not write the ideas on the board.

We have been talking about different foods that are available at markets all around the world. Pretend that you are going shopping at a market today for your family's dinner.



What would you like to buy?

- Share an example that applies to you.

I think that I will write a sentence that says, "I will buy spaghetti and sauce."

- Review previously introduced emergent-writing strategies.

T-P-S: What are some things that I can do if I don't know how to write some of the words in my sentence? Draw a picture, draw a line, write sounds that I know, copy a word, and remember a word.

I will use these things to write my sentence. You can use them when you write your sentence too.

- Use previously introduced writing strategies to model writing your sentence.

First, count the words on your fingers as you say the sentence again. Then, draw lines on the board to represent each word.

Example:

I am ready to write my sentence. My sentence is, "I will buy spaghetti and sauce."

- **The first word is "I." I can copy "I" from the word wall.** Write "I" on the first line.
- **The next word is "will." What sounds do you hear in "will"?** Repeat the word slowly. Write any letters that students say.
- **"Buy." What sounds do you hear in "buy"?** Write any letters that students say.
- **"I will buy spaghetti..." I can copy that word from the book *More Spaghetti, I Say!*** Get the book, and pretend to use it to copy the word.

- **“And.” What sounds do you hear in “and”?** Repeat the word slowly. Write any letters that students say.
 - **The last word is “sauce.” What sounds do you hear in “sauce”?** Say the word slowly, emphasizing the individual sounds. Write any letters that students say on the last line.
- Reread your sentence, touching each word, or word representation, as you do.

Partner Planning

- Ask students to share what they would like to write with their partners. Encourage them to use the Say-It-Back strategy to show their partners that they are listening.
- Monitor students, and listen to their discussions. Ask one or two students what their partners are planning to write.

Writing

- Distribute pencils and either writing journals or paper.
- Monitor students as they write. Encourage them to use the writing strategies that you have introduced as needed.
- Hold a writing conference with a few students if time permits. On the weekly record form, record the stage of writing that you observe for each of these students.

Sharing

- Ask students to share their sentences with their partners.
- Use the sharing sticks to select one or two students to share their writing with the class. Acknowledge and celebrate any emergent-writing strategies that they have used.



Invite students to recite or sing “Let’s Think About It” as they move to the gathering area.

Let’s Think About It

TIMING GOAL: 20 minutes

Theme-Learning Recap

- Review the learning focus of the day.

Today we have been learning about markets around the world. We know that there are food markets in every country. Many markets sell similar items, such as bread and vegetables, but have their own special types of those items.

- Show the map or globe.

This morning we learned how to say “hello” in several different languages. Does anyone remember any of these new ways to say “hello”? Allow volunteers to offer their “hello”s in whatever languages they would like.

- Introduce the following activity.

Let’s pretend to buy things from markets all over the world. I’m going to give each partnership a letter card. I would like you and your partner to think of something that begins with that sound, maybe a type of food that you might buy in a market. If I had a /l/ card, I might think of /lll/emons.

- Distribute one letter card to each partnership, using the cards for the more common sounds that begin food item names.

Look at your letter card, and think of a food item that begins with that sound. Remember, you can think of something from any market around the world. Allow students a few moments to think of a food item that begins with the sounds they were given.

Now I’m going to give each set of partners a number card. When you get your number card, I’d like you and your partner to pretend to go to a market anywhere in the world and buy that number of the item that you said you were going to buy. When you ask for something at the market, remember to use polite words such as “please” and “thank you.” Let me show you what I mean.



- Select one number card and one letter card.

I have the number (3, 6, 8, etc.) and the letter sound (/l/, /t/, etc.). I’m going to ask the person at the market if I may buy (number, item). First, we need someone to pretend to sell food at the market. Ask a volunteer to be the market seller. (Student’s name) is going to be the market seller. I’m going to be the customer and ask (student’s name) politely if I may buy something from his (or her) market. Listen to how I ask. May I please buy (number, item), sir (ma’am)? Assist the student in answering, using a complete sentence (e.g., “Yes, you may buy seven lemons.”). **If I had the number 4 and the letter sound /m/, I might ask, “May I please buy four mangoes?”**
WGR: How might (student’s name) answer me politely? “Yes, you may buy four mangoes.”

- Distribute one number card to each partnership.

When you get your number card, practice asking your question with your partner. Remember to use your number and your letter sound in your question. And, of course, remember to ask politely.

- Give students time to read their numbers and practice putting a question together using polite words. Listen as students practice putting their questions together, and assist as needed.
- Invite some students to take turns showing the number and letter cards to the group and sharing their questions aloud. Take on the role of the market seller, and answer the questions in the affirmative. Continue as time permits. After students have shared, collect the cards.



- Award pocket points if several students are able to successfully ask a complete question using their number and letter sound and polite language.

Vocabulary Review

- Briefly review the new theme-related vocabulary word. Use My Turn, Your Turn to have students practice saying the word. Then provide a brief definition, and make connections to the contexts in which the word was used today.



Our new word today is “country.” A country is a place where many people live. A country is ruled by one person or a group of people.

T-P-S: When did we see, hear, or use the word “country” today?



- Ask partners to work together to think of a sentence that uses the word. Use the sharing sticks to select a student to share the sentence with the class. Use the Oral-Language Scoring Rubric to score the response. Record the score on the weekly record form.

| Oral-Language Scoring Rubric | |
|------------------------------|---------------------------------------------------------------------------------------|
| 70 | The student does not respond, or the response does not make sense. |
| 80 | The student responds with a word or phrase that makes sense. |
| 90 | The student responds in a complete sentence that makes sense. |
| 100 | The student responds in a complete sentence(s) that makes sense and includes details. |

- Use the suggestions below to help foster oral-language development.

Theme Vocabulary:
country

| Fostering Richer Language | | |
|------------------------------------------------------------------------------------------------------|------------------------------------------------------------------------------------------------------------------------------------------|-----------------------------------------------------------------------------------------------------------------------------------------|
| Student Response | Teacher Prompt | Further Prompting |
| The student responds in an incomplete sentence. Live country. | Good answer. Can you say that in a complete sentence? | If the student is unable to respond in a sentence, model a sentence for him or her. <i>We can say, I live in a country.</i> |
| The student responds in a complete, but not very elaborate, sentence. I live in a country. | You made a complete sentence with the word. Can you add some details to your sentence? OR Can you tell us a little more about the _____? | If the student is unable to add details, prompt with a question about the sentence. Can you tell us the name of your country? |



- Award pocket points if the student is able to create a complete sentence.

Partner Challenge

- Review the Partner Challenge of the day.

We have one more opportunity to earn pocket points today! Let's review our Partner Challenge. Today your challenge was to act out your puppet skit with your partner. In a moment, I will select a partnership to come and do their skit for the class. Be sure to show why one of the puppets is angry and all the Stop and Stay Cool steps.



- Use the sharing sticks to select partnerships to present their puppet skits. Award pocket points if students include showing why one of the puppets is angry and demonstrate all the steps.
- Invite students to compliment the Cool Kid for successfully demonstrating Getting Along Together skills.

Pocket Points for the Day

- Empty the chips from KinderRoo's pouch, and encourage students to join you in counting them.
- Pour the chips into the jar, and observe how close the total is to the reward line.
- Remind students about their reward.

Home Link/Departure



- Invite students to tell their partners one thing that they did or learned today at school.
- Make any announcements or give reminders (upcoming field trips, picture day, etc.).
- Remind students to watch tonight's Home Link show. Tell students to click on the hippopotamus for today's show.
- Read & Respond: **Share a book with someone in your family. Ask him or her to sign your Read & Respond bookmark.**
- Use the hippopotamus stamp to place an animal image on each student's hand.

Day 9 | Ready, Set...

Focus

There are many jobs to do in a market.

| Additional Materials Needed Today | |
|--------------------------------------------|-----------------------------------------------------------------------------------------------------------------------------------------------------------------------------------------------------------------------------------------------------------------------------------------------------------------------------------------------------------------------------------------------------------------------------------------------------------------------------------------------------------------------------------------------------------------------------------------------------------------------------------------------------------------|
| Greetings, Readings, & Writings | <ul style="list-style-type: none"> Classroom Library Lab: Copies of the concepts-of-print book <i>Lunch Time</i> and the trade book <i>Tap-Tap</i>, ear and mouth cards Literacy Lab: Key card for “q” |
| Gathering Circle | <ul style="list-style-type: none"> None |
| Theme Exploration | <ul style="list-style-type: none"> Chart paper and marker Theme vocabulary word cards for “job” and “stock person” or IWB access |
| Rhyme Time | <ul style="list-style-type: none"> KinderCorner 2nd Edition Plus Media and Software flash drive Prepare index cards with the letters “b,” “f,” and “w” written on them (one letter per card). There should be enough cards for each student to have one. |
| STaR | <ul style="list-style-type: none"> Trade book: <i>Tap-Tap</i> |
| 15-Minute Math | <ul style="list-style-type: none"> No new materials |
| Snack/Outside/ Gross-Motor Play | <ul style="list-style-type: none"> A sampling of the fruits shown in the books from this unit (optional) |
| Stepping Stones | <ul style="list-style-type: none"> Key card for “x” or IWB access “Xx” Uppercase and Lowercase Letter Card Letter-Blending Cards (“b,” “o,” “x,” “ch,” “i,” “p”) or IWB access KinderRoo puppet /x/ picture cards (box, six) or IWB access Common /x/ objects (optional) Stepping Stones Partner Practice Booklets for unit 6 Individual writing boards and writing implements (or pencils if writing in the Partner Practice Booklets) KinderCorner 2nd Edition Plus Media and Software flash drive Concepts-of-print book (student copies): <i>Lunch Time</i> |

| Additional Materials Needed Today | |
|-----------------------------------|------------------------------------------------------------------------------------------------------------------------------------------------------------------------------------------------------------------------------------------------------------------------------------------------------------------------------------------------------------------------------------------------------------------|
| Math Mysteries | <ul style="list-style-type: none"> • Ten-Frame Cards for 1–10, one set • Two containers of the same size • Small containers of various sizes (should hold five to twelve cubes each), two containers per partnership • Small plastic bags with twenty linking cubes each, one bag per partnership • Self-stick notes, two per partnership and one for teacher |
| Let's Daydream | <ul style="list-style-type: none"> • “Big Sister,” <i>The 20th Century Children's Poetry Treasury</i>, page 20 |
| Write Away | <ul style="list-style-type: none"> • No new materials |
| Let's Think About It | <ul style="list-style-type: none"> • Home Link animal hand stamp: elephant |

Learning Labs—Additional Materials

| |
|-------------------------------------------------------------------------------------------------------------------------------------------------------------------------------------------------------------------|
| Literacy Lab Play School: Quilted “q”s |
| <ul style="list-style-type: none"> • Quilting “q” Pattern sheets (appendix) • Hole punches • Precut yarn to sew around the “q” patterns • Masking tape for ends of yarn |
| Writing Lab Market Sales |
| <ul style="list-style-type: none"> • Read and Recycle box (containing supermarket circulars) |

Day 9

Greetings, Readings,
& Writings

TIMING GOAL: 15 minutes

| Student Routines | Teacher Routines |
|-------------------------------------------------------------------------------------------------------------------------------------------------------------------------|----------------------------------------------------------------------------------------------------------------------------------------------------------------------------------------------------------------------------------------------------------------------------------------------------------------------------------------------------------------------------------------------------------------------------------------------------------|
| <ol style="list-style-type: none"> 1. Remove coats and backpacks. 2. Turn in homework. 3. Sign in. 4. Self-select activities. | <ol style="list-style-type: none"> 1. Greet parents and students. 2. Remind students to read the Arrival Activities poster as they prepare for their day. 3. Encourage students to describe what they are doing in full sentences as you observe their activities. 4. Observe for student progress with their individualized objectives from the weekly record form. Circle demonstrated skills if applicable. |

Homework

- Read & Respond

Available Activities

Classroom Library Lab

- Display *Tap-Tap* in a prominent place in the library. Invite students to explore the book. Also place a few copies of *Lunch Time* in the lab. Encourage students to practice reading the books with a friend.

Literacy Lab

- Add the key card for “q” to the lab. Encourage students to use the tactile letter-formation materials to practice forming the shape of /q/.

Math Lab

- Same as day 8

Computer/Media Lab

- Same as day 8

Writing Lab

- Same as day 8

Other

- If you have any theme-related puzzles or games, make them available.



Sing a transitional gathering song. Encourage students to sing along as they move to the gathering area.



Gathering Circle

TIMING GOAL: 15 minutes

Routine

1. Welcome students to the Gathering Circle.
2. Check attendance.
3. Discuss yesterday's homework assignment. Award pocket points if at least half the students completed their homework.
4. Remind students about the responsibilities associated with each classroom job as needed.
5. Make sure that students are sitting with their partners for the week.
6. Remind students about the responsibilities of the Cool Kid.

Home Link Debrief

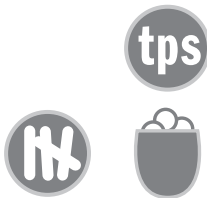

- Invite children to share what they remember from last night's Home Link show.
 T-P-S: **What did you find that begins with the letter "q" in your house?**
- Use the sharing sticks to select two or three children to share their responses with the whole class. Award pocket points in recognition of thoughtful answers.

Partner Challenge

- Introduce the challenge.
Our Partner Challenge today is to show your partner all the Stop and Stay Cool steps you can take when you feel frustrated because you lost your homework that you spent a long time to do just right.
- Allow students to quickly practice with their partners. They will have more opportunities to practice at snack time.

Brain Game



- Review this week's Brain Game.
 T-P-S: **How do we exercise our mind muscles when we play our Brain Game Going to the Market? Demonstrate the Remember Signal (Massage your temples with your fingers.). Let's practice remembering while we play Going to the Market again.**
- Play the game several times now and throughout the day at transitions and other times.



Theme Exploration

TIMING GOAL: 15 minutes

Partnership Question of the Day

tps

T-P-S: Imagine that you are in a market, and food is all around you. What do you smell?

We have been learning all about food stores and markets. I wonder what our Daily Message will tell us about markets today. Let's see!

Daily Message

There are many jobs in a market.

tps

- Write the Daily Message in front of students, reading each word as you finish writing it. Then read the entire message again, touching each word as you read it.
- Reinforce literacy objectives by pointing out the following:
 - Use Stretch and Read to have students read the word “jobs.”
 - Use Think-Pair-Share to have students identify “a” as a word from the word wall.

Theme Learning

tps

- Explain the content of the Daily Message.

Our Daily Message tells us that there are many jobs in a market.

T-P-S: Think about a time when you went to the market. Did you see anyone doing a special job? Think about the different departments in a grocery store and who might work in each of those departments.

- As students share, create a list of their responses. Write the job titles in a list on chart paper, and define each role aloud after writing the job title. If students are unable to name roles, use clues to prompt identification. For example, “As I check out and pay for my groceries, sometimes I notice a person placing all of my groceries in bags. What do you think we might call this person?”
- It is not necessary for students to name every job, but try to include the most obvious ones, as suggested below.
 - **Stock person** – Stock people unpack boxes and arrange items on shelves.
 - **Butcher** – Butchers cut or grind meat and package it.
 - **Baker** – Bakers prepare bread and other baked goods.
 - **Cashier** – Cashiers add up the cost of the groceries and put the money in the cash register.
 - **Bagger** – Baggers put the groceries in bags so they can be carried easily.
 - **Manager** – Managers keep track of the food and the people who work in the market.
 - **Customer/consumer** – Customers/consumers find and purchase groceries.

Teacher's Note: Although customer/consumer is not an actual job, it is this person's responsibility to read labels and make healthy choices and to compare prices.

- Reread the list of jobs. Have all students briefly role-play each job as it is named. (For example, students pretend to unpack and arrange cans of corn on a shelf like a stock person, or they pretend to ring items up on a cash register like a cashier.)
- Count the jobs listed on the chart together with students. Tell students that they might want to pretend to do one of these jobs during Learning Labs today.
- Play the digital dictionary video for "job."
- Re-emphasize the theme-related vocabulary words. Post the words, or point to them on the interactive whiteboard, as you discuss each one.



Our new words for today are "job" and "stock person."

A job is a task that someone does. Just like each of you has a special job in our classroom, each person in a grocery store has a special job. I can make a sentence with the word "job:"

My job is to be a good teacher.

The stock person at a grocery store has a very important job. A stock person unpacks boxes of food and places the food on shelves so customers can find what they need. I can make a sentence with the word "stock person:"

The stock person showed me where to find ketchup in the grocery store.



Ask students to stand up as they sing "It's Time for a Rhyme" to signal the transition to Rhyme Time.

Rhyme Time

TIMING GOAL: 10 minutes

Say the Rhyme

- Have students recite "Food for You and Me." Encourage them to do the physical motions that accompany the rhyme.
- Read the words (see day 6), or play the video.



Develop Phonological Awareness—Identifying Initial Sounds

- Distribute one index card with one of the letters on it to each student. Have students quickly review the sounds on their cards before listening for sounds in the rhyme.

If you have the /b/ card, please stand up. Have all students repeat the sound /b/ before sitting down.

If you have the /f/ card, please stand up. Have all students repeat the sound /f/ before sitting down.

If you have the /w/ card, please stand up. Have all students repeat the sound /w/ before sitting down.

- Explain the activity.

Let's recite our rhyme "Food for You and Me" together. When you hear a word that begins with the sound that you are holding, stand up.

- Recite the rhyme together, emphasizing the words that correspond to the sounds on the index cards. Check to see if all students who are holding the /b/ card stand up on the words "bakers," "bake," "bread," and "butchers." If some students did not stand up on those words, repeat the words, emphasizing the beginning sound /b/.
- Continue reciting the rhyme, stopping after each two lines to check which students are holding the corresponding cards.
- Congratulate students for being excellent listeners and for matching their letters to the sounds heard in the rhyme.
- Collect the cards, and redistribute them so each student has a new sound. Repeat the activity with these new sounds.
- Award pocket points if most students successfully stand when their letter sounds are spoken.



Sing the song "Let's Read Together" with students.



TIMING GOAL: 20 minutes

Review

- Review the title, author, and illustrator.



We read this story yesterday. Do you remember the title? Tap-Tap.

WGR: The author is Karen Lynn Williams. What does the author do? *The author thinks of the story, writes the words.*

WGR: The illustrator is Catherine Stock. What does the illustrator do? *The illustrator paints, draws, and creates the pictures.*

- Review the story vocabulary words. Show the word on a word card or on the interactive whiteboard as you refer to it. Invite partners to make a sentence with each word.



We learned some new words in our story yesterday. The first word was “ached.” What does “ached” mean? *Hurt.* T-P-S: Can you think of a sentence that uses the word “ached”? Work with your partner to think of a sentence.



- Use the sharing sticks to select students to share their responses. Award pocket points for successful responses.
- Repeat this process with the words “journey” and “stack.” *The word “journey” means a long trip. The word “stack” means to place things in a pile.*

Story Retell

- Review the good-reader skill, summarization, and explain that today students will summarize the story *Tap-Tap*.

We know that good readers stop as they read to think about what happens in a story. Yesterday when we read *Tap-Tap*, we stopped to think about what happened in the story and told about it in our own words.

Today we will look at the illustrations in the story and tell what happens on those pages. I will show you pages, and you will talk with the friends in your group about what happens in that part of the story. Then we will use your words to write a sentence. When we finish looking at the illustrations and writing our sentences, we will read what we said happens.

- Quickly place students in groups of four or five by combining partnerships. Present several pages in the beginning of the story, and have students talk in their groups about that part of the story. Ask guiding questions, if necessary, to help students remember what happens.
 - **Pages 1–5:** Show these pages, and ask students to think about what happens in this part of the story. **Talk with the members of your group about what happens in this part of the story. Then make a sentence about it.** If students need help getting started, you can ask a question such as “Where are Sasifi and her mother headed today?”



- Use the sharing sticks to select a group to share their sentence. Help students, as needed, to limit their thoughts to one sentence. Write the sentence on the board.
- Repeat the process of showing several pages, inviting groups to talk about what’s happening and to make a sentence about that part of the story, selecting a group to share their sentence, and writing the sentence on the board.

Suggested pages:

- **Pages 6–9**
- **Pages 10 and 11**
- **Pages 12–15**
- **Pages 16–23**
- **Pages 24–29**
- **Pages 30–34**
- When you get to the end of the book, read each sentence to summarize the story.

- Congratulate students for their hard work in helping to write a summary of the story. **You worked hard in your groups to tell about this story. When we read all these sentences together, we know what the story is about.**
- Transfer the summary to chart paper, and post in the classroom library lab (optional).
- Close the activity by asking students what they would buy at the market if they were Sasifi. T-P-S: **If you were Sasifi and had money to spend at the market, what would you buy?**



Use the 1-2-3 Move signal to move students from the STaR area to the dramatic play lab for the beginning of the lab tour.

Learning Labs

TIMING GOAL: 40 minutes

Routine

1. Have a lab tour to explain the activities or materials in any new labs.
2. Guide students as they select the lab that they will visit. Use the lab-management system to ensure that not too many students plan to visit the same lab at the same time.
3. Students will complete their Learning Lab plan. Conference with as many students as possible about their writing before they are dismissed to labs.
 - Write the code for the writing stage exhibited by the student in the top right-hand corner of the student's paper.
 - Use the methods described in the *Writing Development Feedback Guide* to provide feedback.
4. Monitor students as they visit their selected labs.

Dramatic Play Lab | KinderCorner Market

Description:

- The dramatic play lab will continue to be a market.

When You Tour:

- Remind students that the lab is a market today. Ask students who have already visited the lab to describe some of the jobs they have done in the market.

Blocks Lab | Off to the Market

Description:

- Students will continue to use trucks to deliver fruits and vegetables to the market.

Purpose:

- Remind students that they can deliver fruits and vegetables to the market.

Art Lab | Shopping Bags

Description:

- Students will continue to decorate shopping bags for the KinderCorner Market.

When You Tour:

- Remind students that they can decorate shopping bags for the KinderCorner Market.

Classroom Library Lab | Free Reading

Description:

- Students will continue to explore books independently or with a friend.

When You Tour:

- Remind students that they can explore books independently or with a friend.

Literacy Lab | Play School: Quilted "q"s

Description:

- Students will use materials commonly found in classrooms to play school. In their imaginary classroom today, students will weave yarn into a "q" shape.

Purpose:

- This lab helps students to develop fine-motor skills and reinforces letter shapes and sounds.

When You Tour:

- Tell students that today in their imaginary classroom they can weave yarn into a "q" outline.
- Point out the Quilting "q" Pattern sheets, hole punches, and yarn. Ask a student volunteer to help you punch holes around the "q" on the dots.
- Demonstrate how to weave the yarn in and out of each hole to quilt the "q." As you trace inside the outline of the letter, say, **Left around the queen and way down her staff—/q/, /q/, /q/.**
- Tell students that they may each make a quilted "q" just as you have demonstrated.

Facilitate Learning:

- Students may need to place one hand on top of the other on the hole punch to press hard enough to punch holes in the paper.

- As students weave the yarn through the holes, use language that describes the placement of the yarn as the “q” is being quilted.

Examples:

- **Jamal is weaving his yarn around and around the /q/.**
- **Melody is going up and down through the holes with her yarn.**

Math Lab | The Right Price

Description:

- Students will create price tags for the food items in the KinderCorner Market.

When You Tour:

- Let students know that the lab is open today. Remind them that they can get supplies from the writing or art labs, if necessary, for their price tags. They may also bring their price tags to the KinderCorner Market when they are finished.

Computer/Media Lab | Free Exploration

Description:

- Students will continue to explore educational software or listen to music with computers, CD players, or other digital devices.

When You Tour:

- Remind students that the lab is open today.

Sand/Water Lab | Fill 'er Up

Description:

- Students will continue to fill up various containers with water and sand.

When You Tour:

- Remind students that they can fill up various containers with water and sand.

Science Lab | Which Weighs More?

Description:

- Students will continue to use a scale to compare the weights of various objects.

When You Tour:

- Remind students that they can compare the weights of various objects.

Writing Lab | Market Sales

Description:

- Students will write circulars for sales or signs for products in the KinderCorner Market.

Purpose:

- This lab provides students with an opportunity to practice writing related to the theme and letter-sound correspondence.

When You Tour:

- Point out the sample supermarket circulars in the Read and Recycle box.
- Encourage students to create their own circulars to advertise sales in the KinderCorner Market. They may also make signs to place in the store.

Facilitate Learning:

- Help students make connections among the pictures, words, and numbers on the sale circulars.
- Encourage them to think about the beginning and ending sounds of words they see and to find the corresponding pictures.



Provide five-minute and three-minute warnings before the end of the labs. Then sing the clean-up song to prompt students to put away the lab items and move to the 15-Minute Math board.



15-Minute Math

TIMING GOAL: 15 minutes

Complete the following activities as described on day 1.

Calendar



- Before placing the calendar cutouts on the calendar, ask students what the picture on today's cutout will be. Add the calendar cutout for today's date to the calendar. T-P-S: **Did you know what the picture on the cutout was going to be?** *Replies.* **How did you know?** *It's a pattern.* Point to the calendar again, and say, **Today is** (day of the week), (month and date).

Days of the Week

Days of School Tape

Ten-Frames

Hundreds Chart

Two More and Two Less

- Select a student to clip the clothespin on any number on the 1–5 or 6–10 number-recognition circles. Using the overhead marker, record this number in the middle column on the poster. Then have students identify two more and two less than the number. Record these numbers in the appropriate columns on the poster.



Recite the Stop and Stay Cool rhyme as students move to the area where you will serve the snack.

Snack • Outside • Gross-Motor Play

TIMING GOAL: 30 minutes

Snack

- Serve a buffet of fruits that are featured in the books from this unit. Encourage students to taste a variety of fruits and to use polite words such as “please” and “thank you.” Talk with students about why these foods are good choices for them and how fruit helps them grow.
- Invite students to talk about the Partner Challenge. Our Partner Challenge today is to show your partner all the Stop and Stay Cool steps you can take when you feel frustrated because you lost your homework that you spent a long time to do just right. Allow students time to talk with their partners about all steps of Stop and Stay Cool.
- Award pocket points when students successfully demonstrate the Stop and Stay Cool steps.



Outside/Gross-Motor Play

- For those students needing or wanting structured activities, repeat one or more of the circle games that was introduced earlier in the unit. Encourage students to take turns leading the various cooperative games.



When students come back inside, select one student to play teacher. As students return to the gathering area for Stepping Stones, that student will point to each word on the word wall for the other students to read.

Stepping Stones

TIMING GOAL: 30 minutes



Beginning Phonics: /x/ – a bounced sound

Review

- Have students name each mnemonic picture as you point to it on the wall frieze.
- Ask students to provide the sounds for letters that have already been introduced with uppercase and lowercase cards attached.
- Show the Animated Alphabet segment for /q/.

Introduce the New Sound

Silly Sentence

- Present the KinderRoo puppet. Explain that she has a new sound for them to learn—a sound that they will hear in the silly sentence she has brought. Explain that this special sound will be inside the words, not at the beginning of the words.
- Say the alliterative phrase two or three times, emphasizing the /x/ sound in each word.

The excited fox exercises.

- Use Think-Pair-Share to ask, **What sound do you hear in “excited,” “fox,” and “exercises”?**
- Use My Turn, Your Turn to have students repeat each of the words that contain /x/, emphasizing the /x/ sound in each word.

Let's practice that sound.

| | |
|------------------------------|-------------------------------|
| Teacher: e/x/ cited | Students: e/x/ cited |
| Teacher: fo /x/ | Students: fo /x/ |
| Teacher: e/x/ ercises | Students: e/x/ ercises |

 The /x/ sound is pronounced in isolation as /ks/. We do not bounce the sound when it is inside words, but it can be bounced when said in isolation.



Mnemonic Picture

- Show the picture side of the key card for “x.” Explain that the picture we have to help us remember the sound /x/ is a fox.



Let's watch our funny cartoon about /x/. It will help us to remember the sound.

- Play the Animated Alphabet segment for /x/. Point out that the fox makes the /x/ sound as he exercises.

People, Pictures, and Objects

- Have KinderRoo help you identify any students whose names begin with /x/. Explain that KinderRoo has brought some pictures and objects that begin with /x/. Say the name of each picture or object as you present it, and emphasize the /x/ sound.

box

six

- Ask students to name each picture or object as you point to it. Ask, **What sound do you hear at the end of _____?** as they name each one.



Making the Sound

- Ask students to think about what is happening in their mouths as they make the /x/ sound. Have them face their partners and make the sound several times as you ask the following questions:
 - **Is your mouth open or closed when you make the sound?**
 - **What is your tongue doing when you make the sound?**
 - **Gently touch your throat. Can you feel a vibration when you make the sound?**

Compare Uppercase and Lowercase

- Use the Uppercase and Lowercase Letter Cards to show students what both forms of the letter look like.
- Attach the uppercase and lowercase card next to the corresponding mnemonic picture on the wall frieze.



How are the two letter shapes the same? How are they different?

Partner Practice

Reading Sounds

- Distribute the Partner Practice Booklets and a crayon or pencil to each student. Ask students to open their booklets to page 12. Encourage partners to help each other find the page. Have the partners work together to read the sounds.
 - Jelly will point to the sounds, and Peanut Butter will read them. Jelly will help as needed.
 - After Peanut Butter has finished reading the sounds, Jelly will write their initials in the box at the bottom of Peanut Butter's page.
 - Peanut Butter will point to the sounds, and Jelly will read them. Peanut Butter will help as needed.
 - After Jelly has finished reading, Peanut Butter will write their initials in the box at the bottom of Jelly's page.

Stretch and Read

- Explain that the sounds we have been learning can be put together to make words. Model the process by placing the letter cards for /b/, /o/, and /x/ a few spaces apart in a pocket chart or along a chalkboard tray. Gradually move the letters closer together, and have students blend the sounds together with you until you say “box.” Repeat with the word “chip.”

We know that words are made of sounds. We can read a word by saying all the sounds and blending them together. We call this Stretch and Read.



Alphie and his friends can use Stretch and Read to sound out words too. Let's watch.

- Show the Sound and the Furry video segment.

Now you will get to use Stretch and Read to read some words with your partner. The words you will read are different from the words we read together. Let's see who can figure out the words!

- Have students work with their partners, using Stretch and Read, to read the words from their Partner Practice Booklets.
- Use the sharing sticks to select a student to read the sounds for the class. Select another student to read the words. Provide assistance as needed. Award pocket points if they attempt to read all the sounds or words.



Forming the Letter

Introduce the shape of /x/.

- Explain that now you will show students how to write the letter that makes the /x/ sound. Trace the letter with your finger as you say the letter-writing cue “Left hand to right toe, right hand to left toe.” Ask students to say the cue with you two or three times as you trace the letter again.
- Show the letter-only side of the key card. Make a connection to the letter shape and the mnemonic picture.

Example:

- **What picture does this letter look like? *Exercising fox.* Yes, this letter looks like the exercising fox.**

Write /x/.

- Demonstrate writing the letter in front of students several times on a writing board or chart paper. Ask students to say the writing cue with you as you form the letter.
- Hold the picture side of the key card next to the letters you have written. Ask students whether your letters look like the exercising fox. Place the key card in a pocket chart with the letter side facing outward.
- Guide students to practice forming the letter shape using their fingers as pencils several times in different ways (in the air, on the carpet, on their legs, etc.) Encourage them to say the cue as they write the letter.

- Distribute individual whiteboards and dry-erase markers, chalkboards and chalk, or paper and pencils or crayons. You may also use the space provided in the Partner Practice Booklet for writing. Ask students to write /x/ several times, reciting the cue with them each time.
- Ask students to examine their partners' letters for /x/ and circle the best one. Encourage them to tell their partners why they think it's the best.
- Have students write other letters that they have learned. Encourage them to say the cue as they write each letter.
 - /q/ **Left around the queen and way down her staff.**
 - /y/ **Slant right down one string and way down the other.**
- Include other review letters as needed by your students.

Stretch and Count/Stretch and Spell

- Call out a word, and ask students to break it down as they count the number of sounds in the word on their fingers. Ask them to draw a line for each sound that is represented in the word. Say the sounds in the word again, and have students write the letters that make the sound on the lines to spell the word.

box

chip

- Collect the Partner Practice Booklets.

Emergent Reading

Story Review

- Briefly review the concepts-of-print book *Lunch Time*.
- Review the focus skills.

Point to the word “a” on the word wall. **Remember that you will see the word “a” from our word wall many times in this story.**

You can use the pictures to help you know what to say on each page, but you can also use the first letter of each food word to help you know what sound it should start with.

Partner Reading

- Distribute a book to each student.
- Have students read the story with their partners, alternating pages. When they finish, they should switch parts and read the story again.



Invite students to sing “March to Math” to signal that it is time for Math Mysteries.



Math Mysteries

TIMING GOAL: 25 minutes

Show What You Know



- Show the Ten-Frame Cards for 2 and 5. Use the sharing sticks to select students to identify which one is more. Show the Ten-Frame Cards for 6 and 9. Ask students to identify which one is less.



- Award pocket points if students are able to identify the set that is more and the set that is less in each pair of numbers.
- Show the Ten-Frame Card for the number 7. Ask students to show you a set that is less using their fingers. Ask students to show you a set that is more using their fingers.

Active Instruction

- Tell students that today they will continue learning about more and less, but this time they will think about containers and which one holds more or less. Hold up two containers that are the same size. Ask students to compare the two.

Which container do you think will hold more? Why?

- Hold up two containers that are two different sizes.

Which container do you think will hold more? Why?

- Hold up the two containers that are different sizes.



T-P-S: How can we find out which container holds more? *We can put cubes or other objects in the containers and then count to see which one holds more.*

- Ask students to count the number of cubes you place in the first container. Slowly fill the container as students count. Record the number of cubes on a self-stick note, and attach that note to the container.
- Hold up the second container.



WGR: Do you think this container will hold more or less?

- Ask students to count the number of cubes that you place in the second container. Slowly fill the container as students count. Record the number of cubes on a self-stick note, and attach that note to the container.

T-P-S: Which container holds more? How do you know?



RWE: We can tell that the (first/second) container holds (more/less) because (twelve) is (more/less) than (eight).

- Ask students to count the cubes again as you take them out of the containers and connect them to make two separate sticks. Have students compare the length of the sticks to confirm that one container holds more than the other.
- Repeat this activity with the containers that are the same size.

Sometimes the number of cubes isn't more or less; it is the same. These two containers hold the same number of cubes.

Partner Practice

- Explain that each set of partners is going to get two containers, some linking cubes, and two self-stick notes.

You and your partner are going to find out which of your containers holds more cubes and which holds less cubes (or fewer) just like I did.

- Hold up a self-stick note, and explain that students will record the number of cubes that each container holds on a self-stick note and then attach those notes to the containers.
- Give each partnership their materials. Ask them to predict answers before they begin placing cubes in the containers.

Before you fill your containers with cubes, I want you to predict (or guess) which container will hold more.

- Circulate as students work, and assist students as needed. Watch and listen as students count and place the cubes in the containers. Remind students to record the number of cubes that each container holds on a self-stick note and to place the note on the corresponding container.
- Suggest that they connect the cubes together to form sticks and compare the sticks to confirm which container holds more.
- Challenge students to figure out how many more or fewer cubes can be held by each container. If time allows, you may wish to have partners swap containers and try the activity again.

Recap



- Use the sharing sticks to select several students to share their findings with the class. Ask them to explain which of their containers has more or less and how they know. Award pocket points if several students are able to identify which of their containers holds more or less and to explain how they know.
- Review the concepts of more and less.



T-P-S: How do we know if one number is more or less than another number?



RWE: We know that one number is more or less than another number by counting out sets to represent each number and comparing them.



- Play the “Volume: Which Holds More?” video to reinforce concepts of more and less.



Sing “It’s time to go to sleep. It’s time to count our sheep.” Then count in a quiet voice, touch each student lightly on the head, and send them to retrieve their nap-time supplies.



Let's Daydream

TIMING GOAL: 25 minutes

Routine

1. Have students get out their supplies (towels, cots, etc.) for nap time.
2. Read the selected poetry, and play soft music (optional) as students rest.
3. Allow students to quietly look at another book during this time if they prefer.

Recommended Poetry Selection

- “Big Sister,” *The 20th Century Children's Poetry Treasury*, page 20

Introduce the Poem

We've been talking about how important it is to eat healthful foods so we can grow up strong and healthy. Today's poem is about a boy who wants to grow as big and tall as his sister. Listen to the boy's secret about how he will do that.



Gather students in a place where you will model during Write Away.



Write Away

TIMING GOAL: 20 minutes

Prewriting

- Present the writing topic for the day, and encourage students to share their ideas. To discourage copying later, do not write the ideas on the board.

We know that there are many types of markets. There are bakeries, fruit stands, and many more. Today you are going to write about one type of market.



Choose a market you would like to visit. What kinds of foods would you see at that market?

- Share an example that applies to you.

I think that I will write a sentence that says, “I would see rolls at a bakery.”



- Review previously introduced emergent-writing strategies.

T-P-S: What are some things that I can do if I don't know how to write some of the words in my sentence? *Draw a picture, draw a line, write sounds that I know, copy a word, and remember a word.*

I will use these things to write my sentence. You can use them when you write your sentence too.

- Use previously introduced writing strategies to model writing your sentence.

First, count the words on your fingers as you say the sentence again. Then, draw lines on the board to represent each word.

Example:

I am ready to write my sentence. My sentence is, "I would see rolls at a bakery."

- **The first word is "I." I can copy "I" from the word wall.** Write "I" on the first line.
 - **The next word is "would." What sounds do you hear in "would"?** Repeat the word slowly. Write any letters that students say.
 - **"See." I'm going to draw a pair of eyes to stand for "see."** Draw a pair of eyes.
 - **"I would see rolls at a bakery." The next word is "rolls." I hear the /r/, /l/, and /s/ sounds in "rolls."** Write each letter as you say the sound.
 - **"At." I remember how to write "at."** Write "at."
 - **"A" is the next word. It is on the word wall, so I can copy it.** Write "a."
 - **The last word is "bakery." What sounds do you hear in "bakery"?** Say the word slowly, emphasizing the individual sounds. Write any letters that students say on the last line.
- Reread your sentence, touching each word, or word representation, as you do.

Partner Planning

- Ask students to share what they would like to write with their partners. Encourage them to use the Say-It-Back strategy to show their partners that they are listening.
- Monitor students, and listen to their discussions. Ask one or two students what their partners are planning to write.

Writing

- Distribute pencils and either writing journals or paper.
- Monitor students as they write. Encourage them to use the writing strategies that you have introduced as needed.
- Hold a writing conference with a few students as time permits. Record the stage of writing that you observe for some students on the weekly record form.

Sharing



- Ask students to share their sentences with their partners.
- Use the sharing sticks to select one or two students to share their writing with the class. Acknowledge and celebrate any emergent-writing strategies that they have used.



Invite students to recite or sing “Let’s Think About It” as they move to the gathering area.

Let’s Think About It

TIMING GOAL: 20 minutes

Theme-Learning Recap



- Review the learning focus of the day.

Today we have been learning about the different jobs people have in a market. T-P-S: What are some of the jobs a person can have in a food market?

- Display the list of jobs that you composed with students during Theme Exploration this morning. Slowly read the list of jobs with students. After each job is named, ask, **What is that person’s job in the market?**
- Cut the list of jobs apart. Group students into four- or five-member teams.

We are going to play an acting game. I will give each team a special job in the market. With your team, you will act out your job. You will act out your job with actions, but no words. The other students in our class will have to guess which job your team is acting out.

- Distribute one job title to each group. Whisper their job titles to them.
- Allow students time to decide how they will act out their jobs. Assist students, and make suggestions for pantomiming as needed.
- Have each team take a turn pantomiming its job for the rest of the class. The audience should try to guess the team’s job.
- Continue until every team has had a chance to act out their job.



Vocabulary Review

- Briefly review the new theme-related vocabulary words. Use My Turn, Your Turn to have students practice saying each word. Then provide a brief definition, make connections to the contexts in which the word was used today.



One of our new words today is “job.” A job is a task. T-P-S: When did we see, hear, or use the word “job” today?

Our other new word today is “stock person.” A stock person is a person who unpacks boxes and organizes items on shelves. T-P-S: When did we see, hear, or use the word “stock person” today?



- Ask partners to work together to think of a sentence that uses one of the words. Use the sharing sticks to select a student to share the sentence with the class. Use the Oral-Language Scoring Rubric to score the response. Record the score on the weekly record form.

| Oral-Language Scoring Rubric | |
|------------------------------|---------------------------------------------------------------------------------------|
| 70 | The student does not respond, or the response does not make sense. |
| 80 | The student responds with a word or phrase that makes sense. |
| 90 | The student responds in a complete sentence that makes sense. |
| 100 | The student responds in a complete sentence(s) that makes sense and includes details. |

- Use the suggestions below to help foster oral-language development.

Theme Vocabulary:

job
stock person

| Fostering Richer Language | | |
|----------------------------------------------------------------------------------------------------------------|------------------------------------------------------------------------------------------------------------------------------------------|------------------------------------------------------------------------------------------------------------------------------------------------------------------------------|
| Student Response | Teacher Prompt | Further Prompting |
| The student responds in an incomplete sentence. I job. | Good answer. Can you say that in a complete sentence? | If the student is unable to respond in a sentence, model a sentence for him or her. <i>We can say, I have a job.</i> |
| The student responds in a complete, but not very elaborate, sentence. I have a job in our classroom. | You made a complete sentence with the word. Can you add some details to your sentence? OR Can you tell us a little more about the _____? | If the student is unable to add details, prompt with a question about the sentence. Can you tell us more about which job you are doing in our classroom this week? |



- Award pocket points if the student is able to create a complete sentence.

Partner Challenge

- Review the Partner Challenge of the day.

We have one more opportunity to earn pocket points today! Let's review our Partner Challenge. Invite students to talk about the Partner Challenge. **Our Partner Challenge today is to show your partner all the Stop and Stay Cool steps you can take when you feel frustrated because you lost your homework that you spent a long time to do just right.** Allow students time to review what they told their partners earlier in the day.



- Use the sharing sticks to select students to share their responses. If you feel your students are able, have them tell their partners' responses. Award pocket points when students successfully demonstrate the Stop and Stay Cool steps.
- Invite students to compliment the Cool Kid for successfully demonstrating Getting Along Together skills.

Pocket Points for the Day

- Empty the chips from KinderRoo's pouch, and encourage students to join you in counting them.
- Pour the chips into the jar, and observe how close the total is to the reward line.
- Remind students about their reward.

Home Link/Departure



- Invite students to tell their partners one thing that they did or learned today at school.
- Make any announcements or give reminders (upcoming field trips, picture day, etc.).
- Remind students to watch tonight's Home Link show. Tell students to click on the elephant for today's show.
- **Read & Respond: Share a book with someone in your family. Ask him or her to sign your Read & Respond bookmark.**
- Use the elephant stamp to place an animal image on each student's hand.

Day 10 | Ready, Set...

Focus

There are many different kinds of places where people can buy food.

| Additional Materials Needed Today | |
|--------------------------------------------|------------------------------------------------------------------------------------------------------------------------------------------------------------------------------------------------------------------------------------------------------------------------------------------------------------------------------------------------------------------------------------------------------------------------------|
| Greetings, Readings, & Writings | <ul style="list-style-type: none"> Literacy Lab: Key card for “x” |
| Gathering Circle | <ul style="list-style-type: none"> KinderRoo, Alex, and Joey puppets (from day 8) KinderCorner 2nd Edition Plus Media and Software flash drive |
| Theme Exploration | <ul style="list-style-type: none"> Food-place signs (see To Be Prepared section in You Will Need) Grocery bag with food items or food pictures Theme vocabulary word cards for “store” and “stand” or IWB access |
| Rhyme Time | <ul style="list-style-type: none"> KinderCorner 2nd Edition Plus Media and Software flash drive Use the box, basket, or grocery bag of food items from day 6. Add foods whose names have four syllables such as cauliflower, watermelon, or macaroni. |
| STaR | <ul style="list-style-type: none"> A storybook to read for free-choice day |
| 15-Minute Math | <ul style="list-style-type: none"> What Holds More? poster Eight to ten containers of various sizes Linking cubes (enough to fill the largest container) |
| Snack/Outside/ Gross-Motor Play | <ul style="list-style-type: none"> Leftovers from snacks served earlier in the week (optional) |
| Stepping Stones | <ul style="list-style-type: none"> KinderCorner 2nd Edition Plus Media and Software flash drive Picture cards for /y/, /q/, and /x/ Partner Practice booklets for unit 6 |
| Math Mysteries | <ul style="list-style-type: none"> Two containers filled with linking cubes and labeled with the number of cubes in each container Small containers, one for the teacher and one per partnership Small plastic bags of bear counters, bicolored counters, buttons, and beads, ten to thirty of each type per partnership How Many Will It Hold? sheets (appendix), one per student |
| Let's Daydream | <ul style="list-style-type: none"> “The Click Clacker Machine,” <i>The 20th Century Children's Poetry Treasury</i>, page 33 |

| Additional Materials Needed Today | |
|-----------------------------------|------------------------------------------------------------------------------------------------------------------------------------------------------------------------------------------------------------------------------------------------------------------|
| Write Away | <ul style="list-style-type: none"> • No new materials |
| Let's Think About It | <ul style="list-style-type: none"> • Happy-or-sad-face sticks (from unit 2) • KinderCorner 2nd Edition Plus Home Link Letter for unit 7: <i>Sing a Song—Paint a Picture</i>, one per student (appendix) • Cool Kid certificates |

Learning Labs—Additional Materials

- SOLO assessment for your current grading period

Day 10 Greetings, Readings, & Writings

TIMING GOAL: 15 minutes

| Student Routines | Teacher Routines |
|-------------------------------------------------------------------------------------------------------------------------------------------------------------------------|----------------------------------------------------------------------------------------------------------------------------------------------------------------------------------------------------------------------------------------------------------------------------------------------------------------------------------------------------------------------------------------------------------------------------------------------------------|
| <ol style="list-style-type: none"> 1. Remove coats and backpacks. 2. Turn in homework. 3. Sign in. 4. Self-select activities. | <ol style="list-style-type: none"> 1. Greet parents and students. 2. Remind students to read the Arrival Activities poster as they prepare for their day. 3. Encourage students to describe what they are doing in full sentences as you observe their activities. 4. Observe for student progress with their individualized objectives from the weekly record form. Circle demonstrated skills if applicable. |

Homework

- Read & Respond

Available Activities

Classroom Library Lab

- Same as day 9

Literacy Lab

- Add the key card for “x” to the lab. Encourage students to use the tactile letter-formation materials to practice forming the shape of /x/.

Math Lab

- Same as day 9

Computer/Media Lab

- Same as day 9

Writing Lab

- Same as day 9

Other

- If you have any theme-related puzzles or games, make them available.



Sing a transitional gathering song. Encourage students to sing along as they move to the gathering area.

Gathering Circle

TIMING GOAL: 15 minutes

| Routine |
|------------------------------------------------------------------------------------------------------------------------------------------------------------------------------------------------------------------------------------------------------------------------------------------------------------------------------------------------------------------------------------------------------------------------------------------------------|
| <ol style="list-style-type: none"> 1. Welcome students to the Gathering Circle. 2. Check attendance. 3. Discuss yesterday's homework assignment. Award pocket points if at least half the students completed their homework. 4. Remind students about the responsibilities associated with each classroom job as needed. 5. Make sure that students are sitting with their partners for the week. |

Home Link Debrief

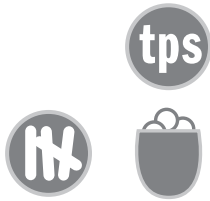

- Invite children to share what they remember from last night's Home Link show.
T-P-S: In last night's show, you learned about different jobs. What was one of the jobs you learned about?
- Use the sharing sticks to select two or three children to share their responses with the whole class. Award pocket points in recognition of thoughtful answers.

Class Council



- Review the Stop and Stay Cool steps.
We've been practicing the steps for Stop and Stay Cool to help us keep from getting so angry that we lose control. The more we know about how we feel and how to control our angry feelings, the better we'll be able to get along with our classmates.
We're going to watch our video about Chilly the Penguin again. This time you are going to see a new part about what happens when Chilly loses his cool!
- Show the "Stop and Stay Cool" video.
- Use all the Getting Along Together skills previously introduced to address any classroom concerns. If there are no unresolved class problems that you need to address, have students use the Alex and Joey stick puppets to create a skit in which the characters need to use the Stop and Stay Cool steps. Allow students to brainstorm problem situations, or suggest one based on past conflicts that you have observed in your group.



Theme Exploration

TIMING GOAL: 15 minutes

Partnership Question of the Day



T-P-S: If you could have your own food store, what kind of store would you like to have? Why?

We have been learning all about food stores and markets. I wonder what our Daily Message will tell us about markets today. Let's find out!

Daily Message

there are many types of places where people can buy food

- Write the Daily Message in front of students, beginning the first word with a lowercase letter and omitting the period from the end of the sentence. Read each word as you finish writing it. Then read the entire message again, touching each word as you read it.
- Reinforce literacy objectives by pointing out the following:
 - T-P-S: **What is missing from this sentence?** *An uppercase letter at the beginning and a period at the end.* Erase the lowercase “t,” and add an uppercase “T” in its place.
 - T-P-S: **Why do we put a period at the end of a sentence?** *So we know that the sentence is finished.* Add a period to the end of the sentence.



Theme Learning



- Explain the content of the Daily Message.

There are many different kinds of places where people can buy food.

Some are small outdoor markets. Food might be set up on tables or shelves. We call these small outdoor markets stands. Sometimes a stand sells just one kind of food such as a hotdog stand.

When food is sold indoors, we call it a store or a shop. There are many different kinds of food stores. There are bakeries, delis, and candy stores, to name a few!

When many different kinds of foods are sold inside the same store, we call it a grocery store, or supermarket, because we can find just about any type of food we need inside that store.

- Introduce the following activity.

I'd like to play a game about different places where we can buy food. We're going to work in small groups today. Each group will pretend to work in a different kind of place. Each of the places will have just one kind of food.

- Combine partnerships to create five groups of students. Give each group a sign for their food place, and briefly explain the kind of food sold at that place.
- Invite students to take turns selecting one food item at a time from the bag and holding it up for everyone to see. Instruct each group to quietly discuss in which place that food item would be sold. Allow time for discussion. When the students in a group have finished discussing, they should join hands together in the air.
- When all teams are ready, ask one member of a team to share his or her team's response, speaking in a complete sentence (e.g., "Oranges can be bought at a produce stand."). The other teams can agree or disagree with the response by giving a thumbs-up or thumbs-down signal. If there is a disagreement, discuss why that particular food would be found in a particular market. When a decision has been reached, present the food item to the appropriate market to display in front of their group.
- Continue playing as time allows, ensuring that items from each market are selected.
- Play the digital dictionary videos for "store" and "stand."
- Re-emphasize the theme-related vocabulary words. Post each word, or point to it on the interactive whiteboard, as you discuss it.



Our new words for today are "store" and "stand."

A store is a building where you can buy things. Some stores sell food. Other stores sell clothes, furniture, toys, or other things. I can make a sentence with the word "store:"

I buy food at the grocery store.

A stand is an outdoor space where things are sold. A stand might just be a table, or it might be a larger outdoor area with many tables and shelves. I can make a sentence with the word "stand:"

I bought a drink from the children at their lemonade stand.



Ask students to stand up as they sing "It's Time for a Rhyme" to signal the transition to Rhyme Time.

Rhyme Time

TIMING GOAL: 10 minutes

Say the Rhyme

- Have students recite "Food for You and Me." Encourage them to do the physical motions that accompany the rhyme.
- Read the words (see day 6), or play the video.



Develop Phonological Awareness—Counting Syllables



- Introduce the activity to students by clapping out the number of syllables in the name of a student. **Le** (Clap.) **-vy.** (Clap.) WGR: **How many syllables are in “(name)”?**
- Tell students they will count out the number of syllables that they hear in words today.
- Distribute five manipulatives or counters to each student. Tell students that each counter will represent one syllable in a word.
- Demonstrate by saying the name of another student in the class (preferably a student with a four- or five-syllable name). As you pronounce each syllable, place one counter in front of you. Be sure to arrange the counters in a line from left to right.
- Repeat the student’s name, pointing to each counter as you say the syllable that it represents. Then count the number of counters in front of you.
E-liz-a-beth (Point to each counter.). **1, 2, 3, 4** (Point to each counter.). **There are four syllables in “Elizabeth.”**
- Invite students to complete the activity with you as you pull an item of food out of your grocery bag. Say the name of the item twice, once at a normal speed and once to emphasize each syllable.
- Invite students to say the word with you slowly as they place a counter in front of them on each syllable. Prompt students to repeat the word, pointing to each counter on its respective syllable, and then to count the number of syllables in the word.
- Ask students how many syllables are in the word.
- Repeat this process with four to five names of food items.
- Award pocket points if several students are able to successfully count the number of syllables in each name or word that you pronounce.



Sing the song “Let’s Read Together” with students.



TIMING GOAL: 20 minutes



- Reread a favorite STaR book or another book that you would like to share.
- Use Think-Pair-Share to have students share their favorite parts of the book.
- See the Resource Corner in the appendix for other great stories that support this theme. You may already have some of them in your classroom, school, or public library.



Use the 1-2-3 Move signal to move students from the STaR area to the dramatic play lab for the beginning of the lab tour.



TIMING GOAL: 40 minutes

Routine

1. Have a lab tour to explain the activities or materials in any new labs.
2. Guide students as they select the lab that they will visit. Use the lab-management system to ensure that not too many students plan to visit the same lab at the same time.
3. Students will complete their Learning Lab plan. Conference with as many students as possible about their writing before they are dismissed to labs.
 - Write the code for the writing stage exhibited by the student in the top right-hand corner of the student's paper.
 - Use the methods described in the *Writing Development Feedback Guide* to provide feedback.
4. Administer the SOLO to a few students while the rest of the class is engaged in lab activities. Record the SOLO scores in the space provided on the weekly record form.

Dramatic Play Lab | KinderCorner Market

Description:

- The dramatic play lab will continue to be a market.

When You Tour:

- Remind students that the lab is a market today.

Blocks Lab | Off to the Market

Description:

- Students will continue to use trucks to deliver fruits and vegetables to the market.

Purpose:

- Remind students that they can deliver fruits and vegetables to the market.

Art Lab | Shopping Bags

Description:

- Students will continue to decorate shopping bags for the KinderCorner Market.

When You Tour:

- Remind students that they can decorate shopping bags for the KinderCorner Market.

Classroom Library Lab | Free Reading

Description:

- Students will continue to explore books independently or with a friend.

When You Tour:

- Remind students that they can explore books independently or with a friend.

Literacy Lab | Play School: Quilted “q”s

Description:

- Students will continue to weave yarn into a “q” shape.

When You Tour:

- Remind students that they can weave yarn into a “q” shape.

Math Lab | The Right Price

Description:

- Students will create price tags for the food items in the KinderCorner Market.

When You Tour:

- Let students know that the lab is open today. Remind them that they can get supplies from the writing or art labs, if necessary, for their price tags. They may also bring their price tags to the KinderCorner Market when they are finished.

Computer/Media Lab | Free Exploration

Description:

- Students will continue to explore educational software or listen to music with computers, CD players, or other digital devices.

When You Tour:

- Remind students that the lab is open today.

Sand/Water Lab | Fill ‘er Up

Description:

- Students will continue to fill up various containers with water and sand.

When You Tour:

- Remind students that they can fill up various containers with water and sand.

Science Lab | Which Weighs More?

Description:

- Students will continue to use a scale to compare the weights of various objects.

When You Tour:

- Remind students that they can compare the weights of various objects.

Writing Lab | Market Sales

Description:

- Students will continue to make signs for products in the KinderCorner Market.

When You Tour:

- Remind students that they can make signs for products in the KinderCorner Market.



Provide five-minute and three-minute warnings before the end of the labs. Then sing the clean-up song to prompt students to put away the lab items and move to the 15-Minute Math board.



15-Minute Math

TIMING GOAL: 15 minutes

Complete the following activities as described on day 1.

Calendar

Days of the Week

Days of School Tape

Ten-Frames

Hundreds Chart

Two More and Two Less

- Select a student to clip the clothespin on any number on the 1–5 or 6–10 number-recognition circles. Using the overhead marker, record this number in the middle column on the poster. Then have students identify two more and two less than the number. Record these numbers in the appropriate columns on the poster.

This activity will allow students to explore the concept of capacity by predicting which of two containers will hold more and then by checking their predictions. The actual capacity has to be measured with liquid so every part of the container is full. Using cubes to fill a container only gives an approximate idea of capacity, but it's a first step in introducing the concept to students.

What Holds More?

- Show students the variety of containers that you have collected and labeled with letters of the alphabet. Explain that over the next few days, they are going to have the opportunity to explore the containers. Point out the What Holds More? poster that has been added to the 15-Minute Math board. Explain that you will be recording information gathered through their explorations on the poster.
- Select two students to come up. Ask each student to choose a container. Have one student fill one of the containers with linking cubes while you count aloud the number of cubes that fit inside. Then have the rest of the class predict whether the second container will hold more or less than the first container. Ask the second student to transfer the linking cubes from the first container into the second. If the second container holds more than the first, have the student continue to add cubes while you count until the container is full. Record the results on the poster. For example, if container A holds more than container B, record “A holds more than B” on the poster.



Recite the Stop and Stay Cool rhyme as students move to the area where you will serve the snack.



TIMING GOAL: 30 minutes

Snack

- Serve a variety of breads, fruits, vegetables, and other interesting foods that were introduced in this unit. Encourage students to taste and comment on the various foods they are eating. Talk with them about the importance of eating a variety of foods for good health. Encourage them to try something they haven't eaten before. Model for them by saying something like, “I tasted a tomato, and I liked it. It was juicy,” or “I tried a kiwi fruit, and it was sweet.”

Outside/Gross-Motor Play

- Play a variation of the game Duck, Duck, Goose using the names of foods from this unit. Ask students to name two kinds of fruit and substitute them for the words “duck” and “goose.” Encourage students who are involved in the game to think of different types of foods to be named in the game.



When students come back inside, select one student to play teacher. As students return to the gathering area for Stepping Stones, that student will point to each word on the word wall for the other students to read.

Stepping Stones

TIMING GOAL: 30 minutes

Beginning Phonics: Review /y/, /q/, and /x/

Remember the Review Sounds



- Explain that today students will review the last three new sounds that they learned.
- Show the Animated Alphabet segments for /y/, /q/, and /x/.

Review Games

Letter Detectives

- Display the key cards for the three review sounds. Have partnerships search the classroom for either objects that begin with one of the review sounds or a word that contains one of the review letters. Students should stand next to the object or word that they find. Ask each partnership to share their object or word with the class.



- Award pocket points if most students successfully find objects or words that represent the review sounds.

Body Formation

- Invite students to form the shape of each of the review letters with their bodies.

Picture Cards:

box
six
yield
yogurt
quarter
quilt

Matching Game

- Display the key cards for the three review letters a few spaces apart. Show a picture that begins with one of the review sounds. Provide a moment for students to think and then point to the key card that corresponds to the correct beginning sound of the picture.

Partner Practice

- Ask students to find page 14 in their Partner Practice Booklets.
- Announce which partner should begin, and have students take turns reading the sounds to each other. The listening partners should point to the sounds and provide help as needed. They should write their initials in the box at the bottom of the page once the reading partners have completed the page.
- When partners have finished, have the class read the sounds together. Then use the sharing sticks to select a partnership to read the sounds to the class.





- Invite partners to take turns reading the words. When partners have finished, have the class read the words together. Then use the sharing sticks to select a partnership to read the words to the class.
- Award pocket points if students read the sounds and words successfully.

Writing

- Distribute writing supplies (mini whiteboards and dry-erase pens, chalkboards and chalk, crayons and paper, etc.) to each student.
- Have students write letters for sounds as you call them out, reinforcing the writing cues as needed. Include the sounds that were introduced this week and those for which students have not yet demonstrated mastery as recorded on the weekly record form.
 - /y/ **Slant right down one string and way down the other.**
 - /q/ **Left around the queen and way down her staff.**
 - /x/ **Left hand to right toe, right hand to left toe.**

Emergent Reading

- Invite students to select one or more concepts-of-print books to read with their partners.
- Monitor students as they read together. When students demonstrate skills, record these observations on the weekly record form.



Invite students to sing “March to Math” to signal that it is time for Math Mysteries.

Math Mysteries

TIMING GOAL: 25 minutes

Show What You Know



- Show students two containers filled with cubes that have self-stick notes attached identifying how many cubes are in each container.

T-P-S: Which container holds more? How do you know?



RWE: The container with _____ cubes holds more because _____ is more than _____.



- Award pocket points if students are able to identify which containers hold more and to explain how they know.
- Show students an empty container.

T-P-S: How can we show how much this container holds?

RWE: We can show how much this container holds by filling it with cubes and counting how many cubes it will hold.

Active Instruction

- Tell students that they will continue to work with containers today. Explain that today they will compare the number of items that different containers will hold.
- Hold up the empty container. Ask students to think about the activity they completed yesterday to help them predict, or guess, how many cubes it will take to fill the container.



T-P-S: How many cubes do you think it will take to fill this container?
Answers will vary.

T-P-S: How can we find out how many cubes it will take to fill this container? *We can fill the container and count the cubes.*

- Record students' predictions on the board or chart paper. Have students count the cubes with you as you fill the container.



WGR: How many cubes did it take to fill this container?

- Record the number of cubes on the board or chart paper. Ask students if any of their guesses were close.
- Empty the container. Tell students you will fill the container again, but that this time you will use large buttons.

T-P-S: Do you think it will take fewer (or less) buttons than cubes, more buttons than cubes, or the same number of buttons as cubes? Why?

- Have students predict how many buttons the container will hold. Record their answers on the board or chart paper. Have students count the buttons with you as you fill the container.

WGR: How many buttons did it take to fill this container?

- Record the number of buttons on the board or chart paper. Ask students if any of their guesses were close.

WGR: Did it take more than, fewer than (less), or the same number of buttons as cubes to fill the container?

- Think aloud, **I wonder why it took more buttons than cubes?**

Partner Practice

- Explain that each set of partners will get one container and several kinds of manipulatives to use to fill the container. Hold up the How Many Will It Hold? sheet. Show students where to record their guesses and the actual number of each manipulative that the container will hold.
- Distribute the How Many Will It Hold? sheets, and explain the activity.

You and your partner will start with the bear counters. Point to the bear-counter part of the sheet. **You and your partner will guess how many bears it will take to fill up your container, and you will write your guess next to the picture of the bear.** Then one of you will place the bear counters in the container while your partner counts. **You will record the number of bear counters it takes to fill the container in the box next to your guess.** Point to this part of the sheet.

You may want to ask students to record their predictions in crayon so they are not tempted to change their answers after finding the actual number that the container can hold.

- Explain to students that they will take turns placing the chips, buttons, and beads in their containers and counting them.
- Distribute the materials to each partnership. Remind students to predict before they begin placing manipulatives in the containers and to record their predictions.

Before you fill your containers with cubes, I want you to predict (guess) how many of each item your containers will hold.

- Circulate as students work, and assist them as needed. Watch and listen as students count and place the manipulatives in the containers. Encourage students to also predict whether their containers will hold more or less of each type of manipulative.

Recap



- Use the sharing sticks to select several students to share their findings with the class. Ask them to explain their predictions and the actual number of each manipulative that their containers hold. Award pocket points if several students are able to explain their predictions and the actual number of each manipulative that their containers hold.
- Review the concepts of more and less. Hold up a container filled with bear counters.



WGR: Will this container hold more or less buttons than bear counters?



Sing “It’s time to go to sleep. It’s time to count our sheep.” Then count in a quiet voice, touch each student lightly on the head, and send them to retrieve their nap-time supplies.

Let's Daydream

TIMING GOAL: 25 minutes

Routine

1. Have students get out their supplies (towels, cots, etc.) for nap time.
2. Read the selected poetry, and play soft music (optional) as students rest.
3. Allow students to quietly look at another book during this time if they prefer.



This is a challenging poem to read because it is like a rhythmic tongue twister. You will probably want to practice reading it once or twice to yourself before reading it to students.

Recommended Poetry Selection

- “The Click Clacker Machine,” *The 20th Century Children’s Poetry Treasury*, page 33

Introduce the Poem

Today I’d like to read you a fun poem called “The Click Clacker Machine.” I like this poem because many of the words begin with the

same sound, so it makes it fun to hear. As I read this poem to you, close your eyes, and listen to the sounds. Think about whether the words in “The Click Clacker Machine” sound like the sounds of a real machine.



Gather students in a place where you will model during Write Away.



TIMING GOAL: 20 minutes

Prewriting

- Present the writing activity for the day.

Today instead of writing a new sentence, we will add a sentence to one that we wrote earlier this week. First, you will choose the sentence that you would like to add to. Then, you will tell us more about something you wrote about.

- Share an example that applies to you. Review the four sentences that you wrote this week, and select one to elaborate.

I think I will choose this sentence. Read the selected sentence. **Now I will tell more about my sentence.** Share a new sentence that expands on the information provided in your first sentence.

- Model writing your second sentence using the strategies from the Writing Strategies Bank.
- Reread your new sentence, touching each word, or word representation, as you do.

Partner Planning

- Ask students to share what they would like to write with their partners. Encourage them to use the Say-It-Back strategy to show their partners that they are listening.
- Monitor students, and listen to their discussions. Ask one or two students what their partners are planning to write.

Writing

- Distribute pencils and either writing journals or paper.
- Monitor students as they write. Encourage them to use the writing strategies that you have introduced as needed.
- Hold a writing conference with a few students as time permits. Record the stage of writing that you observe for some students on the weekly record form.

Sharing



- Ask students to share their sentences with their partners.
- Use the sharing sticks to select one or two students to share their writing with the class. Acknowledge and celebrate any emergent-writing strategies that they have used.



Invite students to recite or sing “Let’s Think About It” as they move to the gathering area.

Let's Think About It

TIMING GOAL: 20 minutes

Theme-Learning Recap

- Review the learning focus of the day.

Today we learned about several different types of markets. We know that markets can be indoors or outdoors. Markets can be small, with just a single table at a stand, or they can be large, with huge buildings with many, many aisles of food. Some markets sell one type of food, such as meats, and other markets sell all types of foods.



- Review the learning focus of the week.

We have learned a lot about markets this week. T-P-S: How is food sorted at the market? *By departments.* T-P-S: What are some of the jobs a person can have at a market? *Butcher, baker, cashier, bagger, etc.*

- Show students the happy-or-sad-face sticks, and review their use. Then distribute the sticks with students, and play a quick game to review this week’s theme-related vocabulary words.

We are going to play a game with our happy-or-sad-face sticks to review what we have learned about markets. We have played this game before. One side of the stick shows a happy face. Show students the Agree side of the stick. The other side of the stick shows a sad face. Show students the Disagree side of the stick. I will tell you something about markets. If you agree with what I say or you think I am right, you will show the happy-face side of the stick. If you disagree with what I say or you think I am wrong, you will show the sad-face side of the stick.

- Distribute the happy-or-sad-face sticks, and play the game with students. Offer a series of statements such as those below. When your statement is false and students disagree, ask students to restate the sentence in a way that is true.

Fruits and vegetables are sold in the produce department of a market. *Agree.*

The baker bakes the bread and other grain foods at the market. *Agree.*

All markets are exactly the same. *Disagree. Some markets are small such as fruit stands. Some markets are big such as supermarkets.*

There are many jobs at a market. *Agree.*

The cashier is the person at the market who slices the meat. *Disagree. The cashier scans your items. You pay the cashier for your food. The butcher slices the meat.*

Other countries have markets too. *Agree.*

The first thing you do at a market is go to the checkout line. *Disagree. That is the last thing you do.*

The stock person is the person who puts food on the shelves. *Agree.*



Vocabulary Review

- Briefly review the new theme-related vocabulary words. Use My Turn, Your Turn to have students practice saying each word. Then provide a brief definition, and make connections to the contexts in which the word was used today.



One of our new words today is “store.” A store is a building where things are sold. T-P-S: When did we see, hear, or use the word “store” today?

Our other new word today is “stand.” A stand is an outdoor place where things are sold. A stand might be a table, stall, or set of shelves. T-P-S: When did we see, hear, or use the word “stand” today?



- Ask partners to work together to think of a sentence that uses one of the words. Use the sharing sticks to select a student to share the sentence with the class. Use the Oral-Language Scoring Rubric to score the response. Record the score on the weekly record form.

| Oral-Language Scoring Rubric | |
|------------------------------|---------------------------------------------------------------------------------------|
| 70 | The student does not respond, or the response does not make sense. |
| 80 | The student responds with a word or phrase that makes sense. |
| 90 | The student responds in a complete sentence that makes sense. |
| 100 | The student responds in a complete sentence(s) that makes sense and includes details. |

- Use the suggestions below to help foster oral-language development.

Theme Vocabulary:

store
stand

| Fostering Richer Language | | |
|------------------------------------------------------------------------------------------------------------|------------------------------------------------------------------------------------------------------------------------------------------|-----------------------------------------------------------------------------------------------------------------------------------------------------------|
| Student Response | Teacher Prompt | Further Prompting |
| The student responds in an incomplete sentence. Shop store. | Good answer. Can you say that in a complete sentence? | If the student is unable to respond in a sentence, model a sentence for him or her. <i>We can say, I shop at the store.</i> |
| The student responds in a complete, but not very elaborate, sentence. I like to go to the store. | You made a complete sentence with the word. Can you add some details to your sentence? OR Can you tell us a little more about the _____? | If the student is unable to add details, prompt with a question about the sentence. Can you tell us more about why you like to go to the store? |



- Award pocket points if the student is able to create a complete sentence.

Cool Kids Recognition

- Award certificates to the two students who served as Cool Kids this week and successfully demonstrated the Getting Along Together skills.

Pocket Points for the Day

- Empty the chips from KinderRoo’s pouch, and encourage students to join you in counting them.
- Pour the chips into the jar, and observe how close the total is to the reward line.
- Remind students about their reward.

Home Link/Departure



- Invite students to tell their partners one thing that they did or learned today at school.
- Make any announcements or give reminders (upcoming field trips, picture day, etc.).
- Explain the homework assignment.

Theme Exploration: We have certainly learned a lot about healthy foods and markets. I hope you enjoyed working and learning together as much as I did.

Read & Respond: I’d like you to read with a member of your family this weekend. Perhaps you could read one of the books you got at school and took home. Maybe you could visit the library with some members of your family.

Appendix

| | |
|------------------------------------------------------------------------------------------------------------|-----|
| What Else Can We Get Into? | 279 |
| Resource Corner | 280 |
| Blackline Masters | |
| • <i>Healthy Foods</i> Word Cards | 283 |
| • Sort-by-Size Workmat | 284 |
| • Chilly the Penguin Puppet | 285 |
| • <i>Gregory the Terrible Eater</i> Puppets | 286 |
| • USDA MyPlate Graphic | 287 |
| • Who Is the Tallest? | 288 |
| • <i>The Little Mouse, the Red Ripe Strawberry, and the Big Hungry Bear</i> Sequencing Cards | 289 |
| • Crayon Tape Measure | 290 |
| • Body Measurement Sheet | 291 |
| • Let's Measure Sheet | 292 |
| • <i>At the Market</i> Word-and-Picture Matching Cards | 293 |
| • Circle Workmat | 294 |
| • Joey and Alex Stick Puppets Outlines | 295 |
| • Grocery Store Spinner | 296 |
| • 2–9 Spinner | 297 |
| • More-or-Less Spinner | 298 |
| • Yellow Yo-Yo “y” Pattern | 299 |
| • Ten-Frame Workmat | 300 |
| • Quilting “q” Pattern | 301 |
| • How Many Will It Hold? Workmat | 302 |
| Theme-Introduction Letter | 303 |
| Weekly Record Form Week 1 | 305 |
| Weekly Record Form Week 2 | 306 |

What Else Can We Get Into?

- Take a field trip to a local grocery store and watch the delivery trucks unload; identify the different types of foods being delivered; visit the various departments in the store and draw students' attention to the way foods that are alike are kept together. Do students recognize familiar logos for products they eat?
- Take a trip to a neighborhood restaurant/pizza parlor and have lunch there.
- Invite students' family members in to cook healthy treats with students.
- Make vegetable soup.
- Display vegetables in various forms and challenge students to put like vegetables together (e.g., frozen, canned, raw, pretend spinach).
- Make peanut butter in a blender.
- Bake muffins for a snack.
- Do one of the following story extension activities:

More Spaghetti, I Say!: Students can prepare spaghetti and sauce for a snack. You might want to have them create macaroni necklaces by stringing different-shaped pastas onto a string. For additional fun, have students dye the pasta before stringing a necklace, using the “Pretty Pasta” recipe below.

Pretty Pasta

Ingredients:

| | |
|------------------------------|--------------------------------|
| food coloring | pasta with holes for stringing |
| large plastic jars with lids | rubbing alcohol |
| newspaper | |

Directions:

1. Place some pasta in a jar, leaving plenty of room for shaking.
2. Pour just enough rubbing alcohol in the jar to barely cover the pasta.
3. Add about 10 drops of food coloring to start.
4. Tighten the lid on the jar and shake, shake, shake until all the pasta is covered with the food coloring.
5. Optional: Add more food coloring and shake again for brighter colors.
6. Spread the pasta onto newspaper until dry.

Gregory, the Terrible Eater: Students create a collage of food that Gregory's parents would want him to eat. Students can glue recycled materials, such as packing pieces, scrap paper, plastic utensils, caps, cartons, etc., onto individual paper plates, or prepare a large cutout of a plate for a whole-class project.

The Little Mouse, The Red Ripe Strawberry, and The Big Hungry Bear: Wash and cut fresh strawberries into two pieces and enjoy them for a snack. You may want to have students trace, cut, and fold a strawberry pattern onto red paper and create a classroom strawberry patch.

Resource Corner

Children's Resources

- Ajmera, Maya, & Ivanko, John D. (2005). *Be My Neighbor*. Watertown, MA: Charlesbridge.
- Anderson, Sally Francis (2003). *At the Market*. Baltimore: Success for All Foundation.
- Burningham, John (1997). *The Shopping Basket*. Cambridge, MA: Candlewick Press.
- Canizares, Susan & Chessen, Betsey (1999). *In the Kitchen*. New York: Scholastic.
- Capucilli, Alyssa Satin (2002). *Mrs. McTats and Her Houseful of Cats*. New York: Margaret K. McElderry Books.
- Carle, Eric (1972). *Walter the Baker*. New York: Simon & Schuster.
- (1990). *Pancakes, Pancakes!* New York: Aladdin Paperbacks.
- (1994). *The Very Hungry Caterpillar*. New York: Philomel Books.
- Chanko, Pamela & Berger, Samantha (1999). *Markets*. New York: Scholastic.
- Child, Lauren (2000). *I Will Never Not Ever Eat a Tomato*. Cambridge, MA: Candlewick Press.
- Cipriano, Jeri (2000). *People Everywhere*. New York: Newbridge Educational Publishing.
- Cooner, Donna (1997). *Barney & Baby Bop Go to the Grocery Store*. Allen, TX: Barney Publishing.
- Cottrell, Traci E. (2002). *Pizza, Please!* Baltimore: Success for All Foundation.
- Cowen-Fletcher, Jane (1994). *It Takes a Village*. New York: Scholastic.
- Curiosity Corner Development Team (1999). *Bread and Butter for You and Me*. Baltimore: Success for All Foundation.
- Depree, Helen (1993). *Fruit Salad*. Bothell, WA: Wright Group.
- DK Direct Limited (1999). *What's Inside? My Body*. New York: DK Publishing.
- Ehlert, Lois (1989). *Eating the Alphabet*. New York: Harcourt Brace & Co.
- Flanagan, Alice (1996). *A Busy Day at Mr. Kang's Grocery Store*. New York: Children's Press.
- (1998). *Mr. Santizo's Tasty Treats*. New York: Children's Press.
- Fowler, Allan (1993). *If It Weren't for Farmers*. Danbury CT: Children's Press.
- (1995). *It's a Fruit, It's a Vegetable, It's a Pumpkin*. Chicago: Children's Press.
- Frankel, Alona (1980). *Prudence's Book of Food*. New York: HarperFestival.
- French, Vivian (1995). *Oliver's Vegetables*. New York: Orchard Books.
- Geisel, Theodor Seuss (1960). *Green Eggs and Ham*. New York: Random House.
- Gelman, Rita Golden (1977). *More Spaghetti, I Say!* New York: Scholastic.
- Gray, Kes (2000). *Eat Your Peas*. New York: Dorling Kindersley Publishing.

- Hartmann, Jack (1997). *Shake, Rattle n' Read* (CD). St. Petersburg, FL: Hop 2 It Music.
- (2000). *Language Play & Listening Fun for Everyone!* (CD) St. Peterburg, FL: Hop 2 IT Music.
- Hudson, Cheryl Willis & Ford, Bernette G. (1990). *Bright Eyes, Brown Skin*. East Orange, NJ: Just Us Books.
- Hutchins, Pat (1976). *Don't Forget the Bacon*. New York: Mulberry Books.
- Jenkins, Ella (1990). *Jambo and Other Call and Response Songs and Chants* (audiotape). Washington, DC: Smithsonian Folkways Recordings.
- Krull, Kathleen (2001). *Supermaket*. New York: Holiday House.
- Lee, Dennis (1997). *Dinosaur Dinner with a Slice of Alligator Pie*. New York: Alfred A. Knopf.
- Lobel, Arnold (1981). *On Market Street*. New York: Mulberry Books.
- (1986). *The Arnold Lobel Book of Mother Goose*. New York: Alfred A. Knopf.
- Maccarone, Grace (1998). *I Shop with My Daddy*. New York: Scholastic.
- Manning, Mick & Granström, Brita (1997). *Yum-Yum!* Danbury CT: Grolier.
- Mayer, Mercer (1989). *Just Shopping with Mom*. New York: Golden Books.
- Mooney, Margaret (2000). *Wonderful Wheat*. New York: Newbridge Educational Publishing.
- Morris, Ann (1989). *Bread Bread Bread*. New York: Scholastic.
- Numeroff, Laura Joffe (1991). *If You Give a Moose a Muffin*. New York: HarperCollins.
- Palmer, Hap (1972). *Getting to Know Myself* (CD). Freeport, NY: Educational Activities.
- Parkes, Brenda (2000). *Needs*. New York: Newbridge Educational Publishing.
- Raffi (1979). *The Corner Grocery Store* (audiotape). Cambridge, MA: Rounder Records.
- Reaves, Danny & Yowell, Sandra (2000). *Traditional Tunes* (audiotape). Baltimore: Danny Reaves, Sandra Yowell Productions.
- Robinson, Fay (1992). *We Love Fruit!* Chicago: Children's Press.
- (1994). *Vegetables, Vegetables!* Chicago: Children's Press.
- Rockwell, Lizzy (1999). *Good Enough to Eat*. New York: HarperCollins.
- Rylant, Cynthia (2000). *In November*. San Diego, CA: Harcourt Brace.
- Schertle, Alice (1995). *Down the Road*. San Diego, CA: Harcourt Brace & Co.
- Sendak, Maurice (1990). *Chicken Soup with Rice*. New York: HarperCollins.
- Sharmat, Mitchell (1980). *Gregory, the Terrible Eater*. New York: Scholastic.
- Simon, Francesca (1998). *Where Are You?* Atlanta, GA: Peachtree Publishers.
- Stevens, Janet (1995). *Tops and Bottoms*. San Diego: Harcourt Brace & Co.
- Stevens, Janet & Crummel, Susan Stevens (1999). *Cook-A-Doodle-Do!* San Diego: Harcourt Brace & Co.
- Swain, Gwenyth (1999). *Eating*. Minneapolis, MN: Carolrhoda Books.

Tabor, Nancy Maria Grande (1996). *A Taste of the Mexican Market*. Watertown, MA: Charlesbridge.

Wasik, Barbara (2011). *Fruit Salad*. Baltimore: Success for All Foundation.

——— (2011). *Lunch Time*. Baltimore: Success for All Foundation.

Wells, Rosemary (1997). *Bunny Cakes*. New York: Dial Books for Young Readers.

——— (1998). *Yoko*. New York: Hyperion Books.

Williams, Karen Lynn (1994). *Tap-Tap*. New York: Clarion Books.

Wolf, Aline D. (1986) *Child-size Masterpieces for Steps 1, 2, 3*. Hollidayburg, PA: Parent Child Press.

Wood, Don & Audrey (1984). *The Little Mouse, The Ripe Red Strawberry, and The Big Hungry Bear*. London, England: Child's Play International.

Teacher's Resources

Canfield, J.; Hansen, M. V.; Hawthorne, J. R.; & Shimoff, M. (1996). *Chicken Soup for the Woman's Soul*. Deerfield Beach, FL: Health Communications.

Charner, Kathy (1993). *The Giant Encyclopedia of Theme Activities for Children 2 to 5*. Beltsville, MD: Gryphon House.

Lansky, Vicki (1982). *Feed Me! I'm Yours*. Deephaven, MN: Meadowbrook Press.

——— (1999). *The Taming of the C.A.N.D.Y. Monster*. Minnetonka, MN: Bookpeddlers.

Mayesky, Mary (1998). *Creative Activities for Young Children*. Albany, NY: Delmar Publishers.

National Dairy Council (1998). *Chef Combo's Fantastic Adventures*. Rosemont, IL.

Nyisztor, Diane (1995). *Moving to Learn*. Toronto, Canada: Harcourt Brace & Co.

Roettger, Doris (1992). *Growing Up Healthy*. Carthage, IL: Fearon Teacher Aids.

Wanamaker, N.; Hearn, K.; & Richarz, S. (1979). *More Than Graham Crackers: Nutrition Education and Food Preparation with Young Children*. Washington, D.C.: National Association for the Education of Young Children.

Websites

<http://www.usda.gov/cnpp/KidsPyra/News.htm>

<http://www.nal.usda.gov/fnic/etext/000023.html>

Healthy Foods Word Cards

Print enough copies for each partnership to have one word card. Multiple partnerships may have the same word.

carrots

apples

bread

turkey

green beans

bananas

cereal

Sort-by-Size Workmat

Copy one per partnership. Laminate if possible.

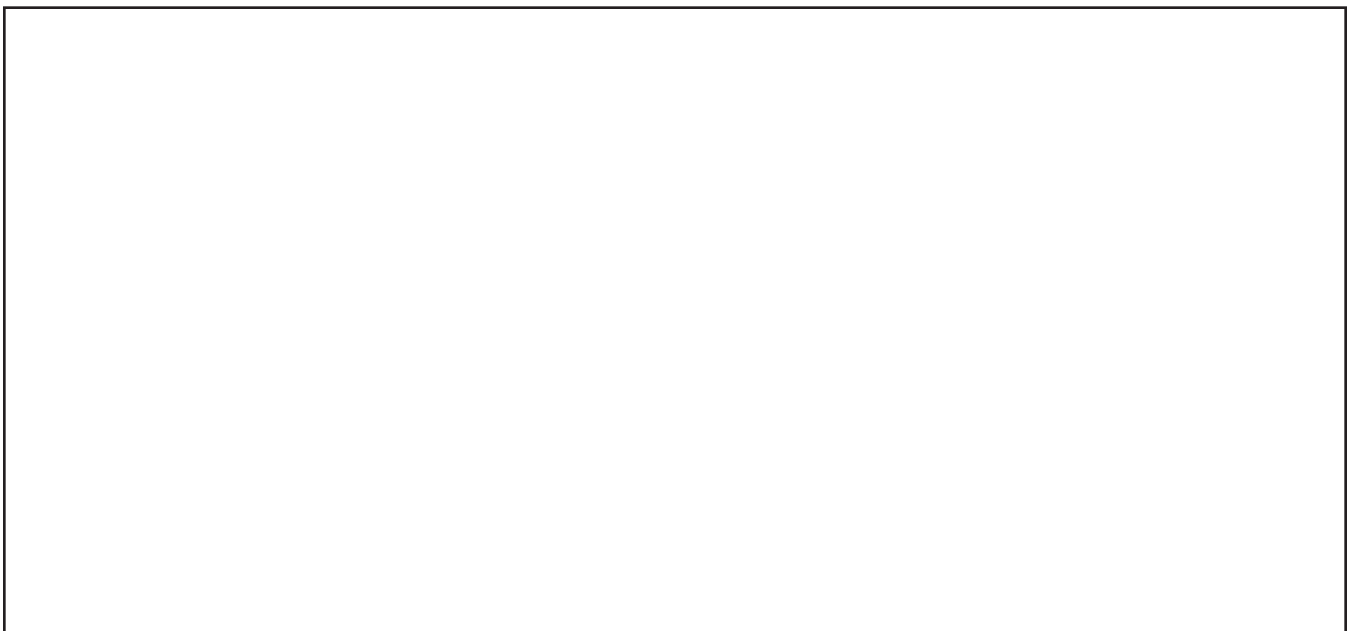
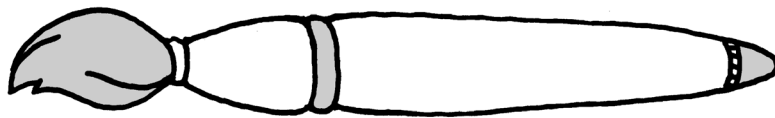
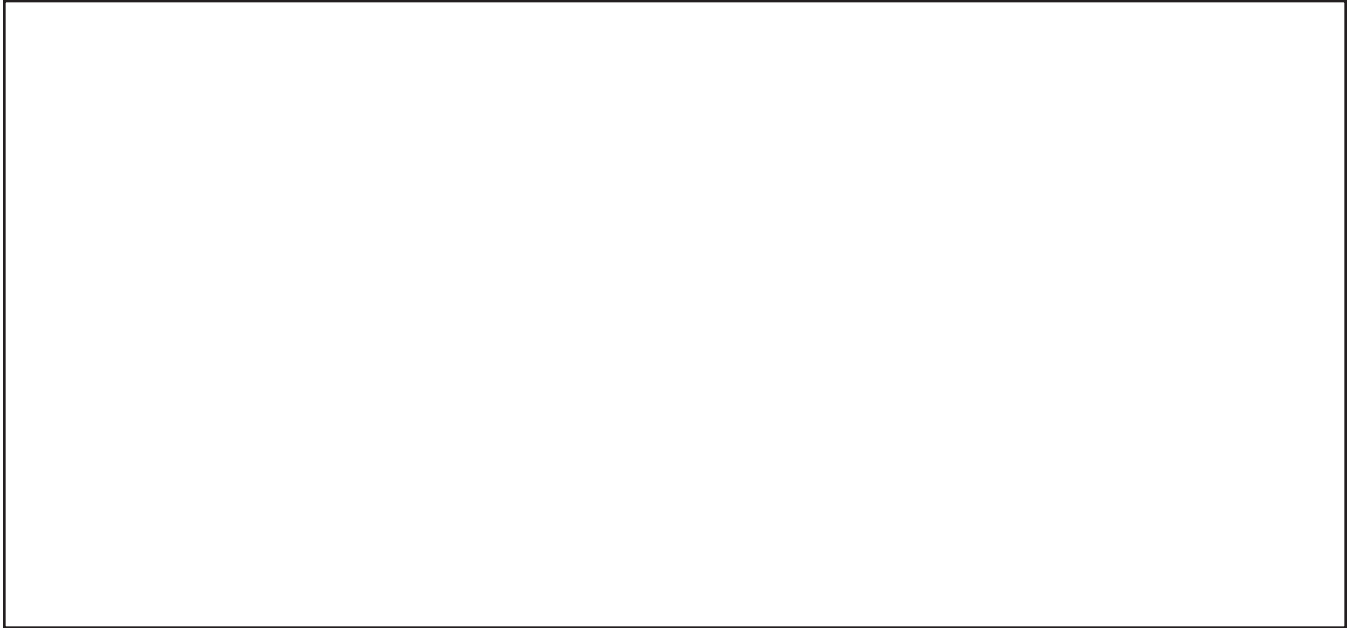

Chilly the Penguin Puppet

Copy, cut, and adhere to a paper bag to create a puppet.



Gregory the Terrible Eater Puppets

Copy to provide one set of puppets per group of four students.

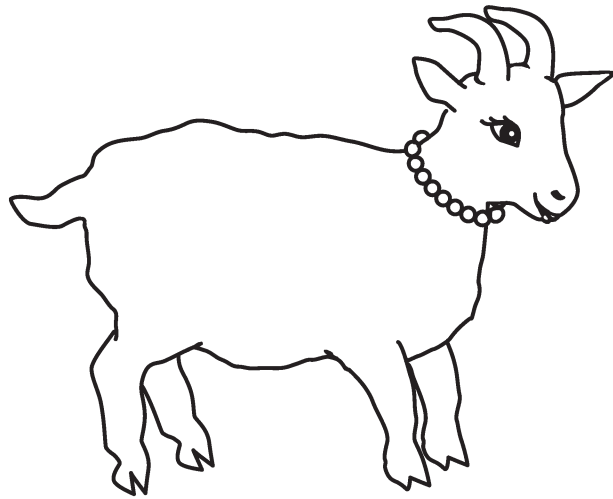

Mother Goat

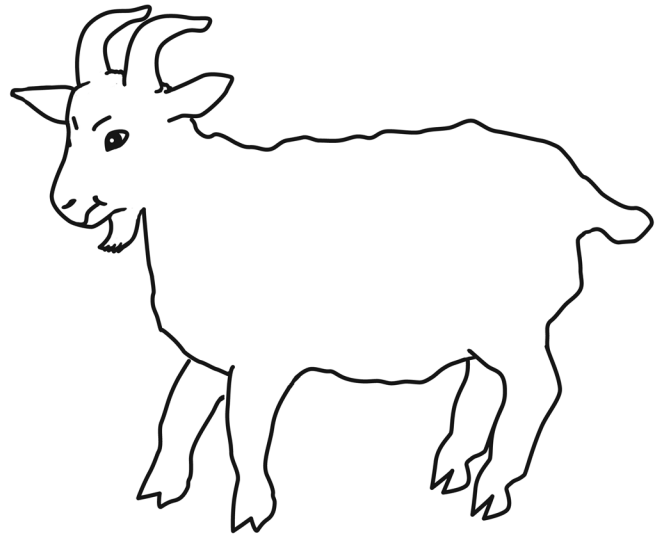

Father Goat

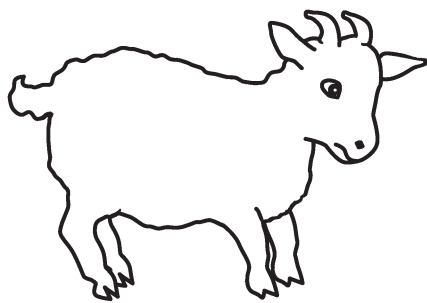

Gregory

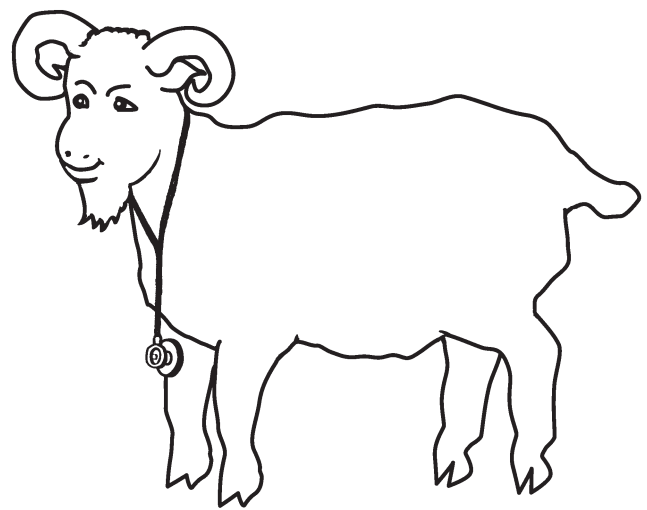

Dr. Ram

MyPlate

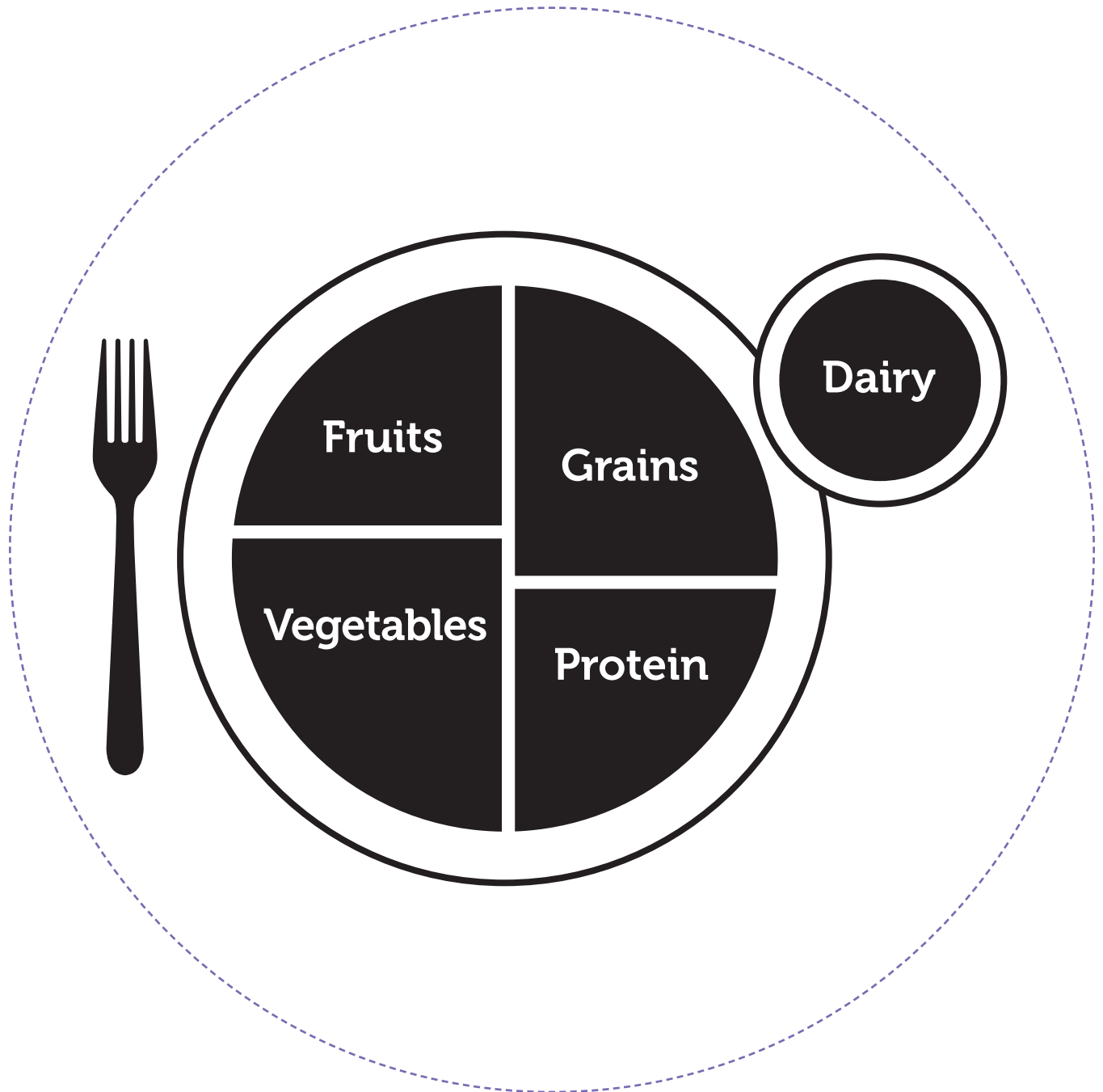

Who Is the Tallest?

Copy one for each partnership.

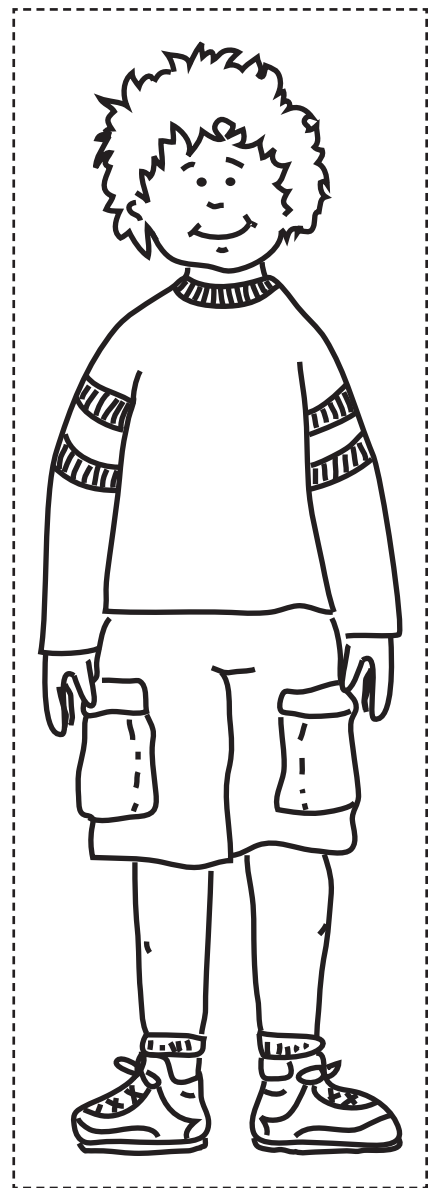
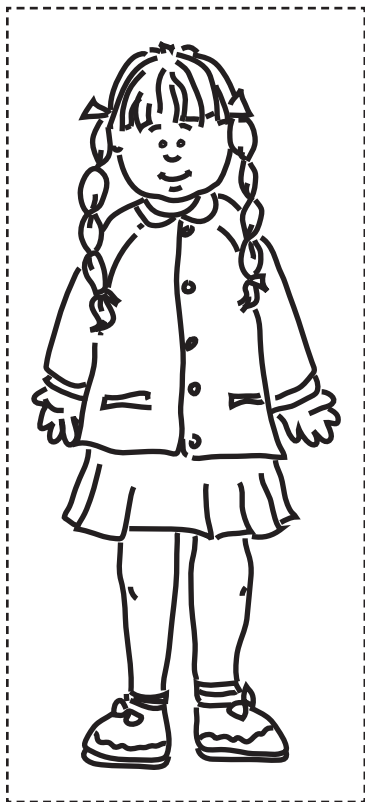

The Little Mouse, the Red Ripe Strawberry, and the Big Hungry Bear Sequencing Cards



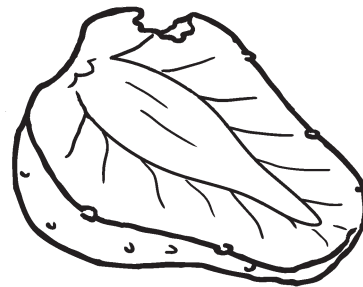
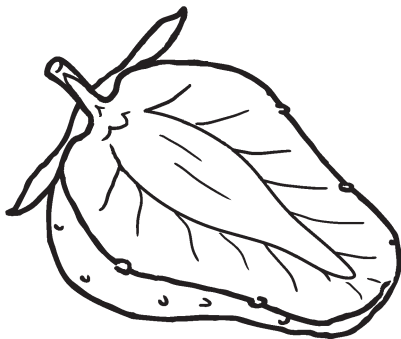
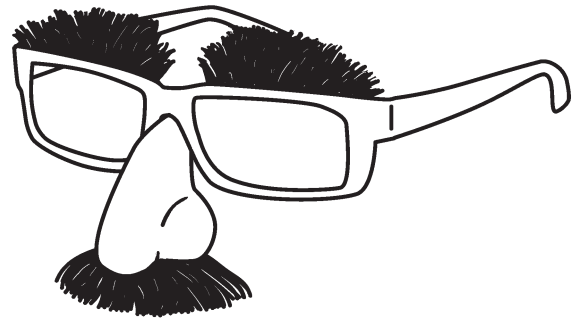
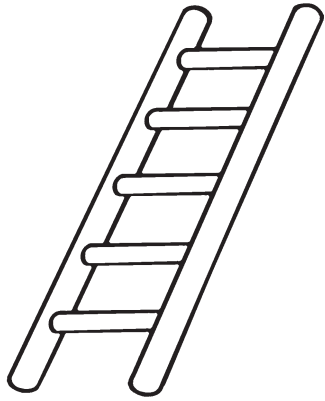





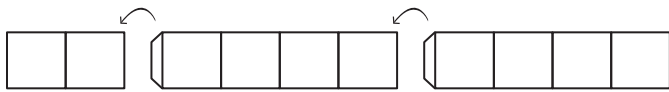

Copy one set of cards for each group of four or five students.



Crayon Tape Measure

Copy one for each partnership. Cut the crayons apart on the dotted lines, and glue them into one long strip.



| | | | |
|-------------------------------------------------------------------------------------|--------------------------------------------------------------------------------------|---------------------------------------------------------------------------------------|--|
| | glue here | glue here | |
| |  |  | |
| |  |  | |
|  |  |  | |
|  |  |  | |
| | (1 of 4) | | |

Body Measurement Sheet

Copy one per student.

My  is about _____ crayons long.

My  is about _____ crayons long.

My  is about _____ crayons long.

My  is about _____ crayons long.

(2 of 4)

Let's Measure Sheet

Copy one per student.

The  is about _____ cubes long.

The  is _____ cubes long.

The  is _____ cubes long.

The  is about _____ cubes long.

At the Market Word-and-Picture Matching Cards

Print enough copies for one set of words and pictures per partnership.

Cut apart to create cards.

bread

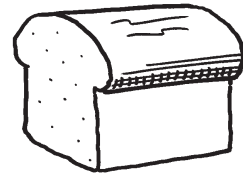

milk



vegetables

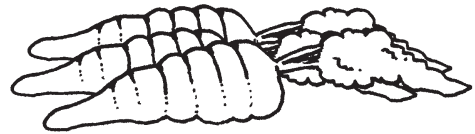

fish

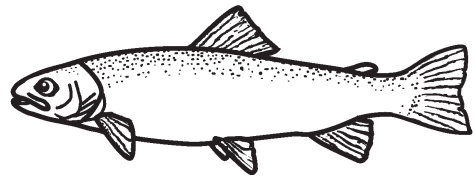

fruit

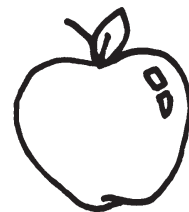

Circle Workmat

Duplicate one per student.

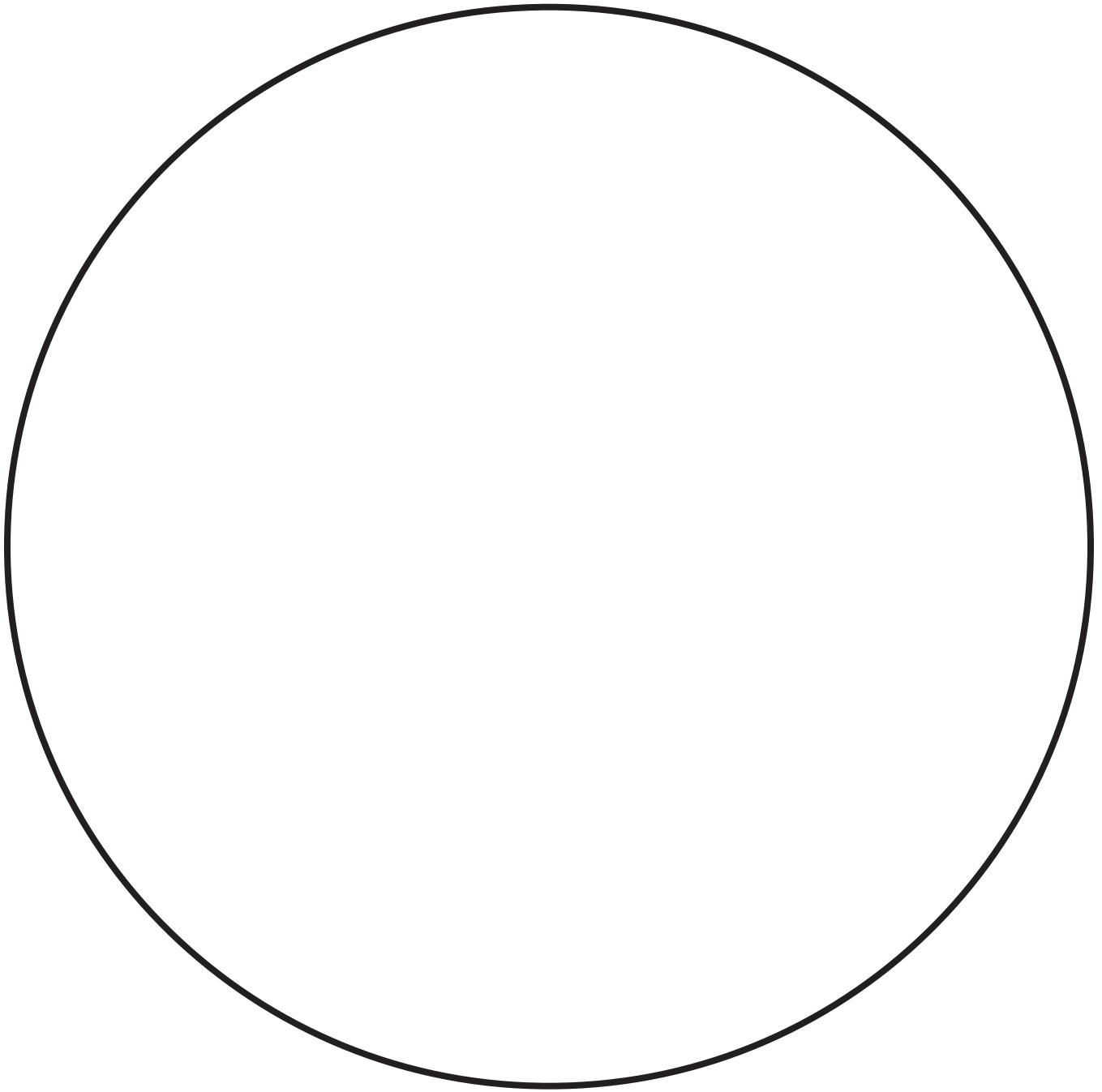

Joey and Alex Stick Puppets Outlines

Make one copy per student.

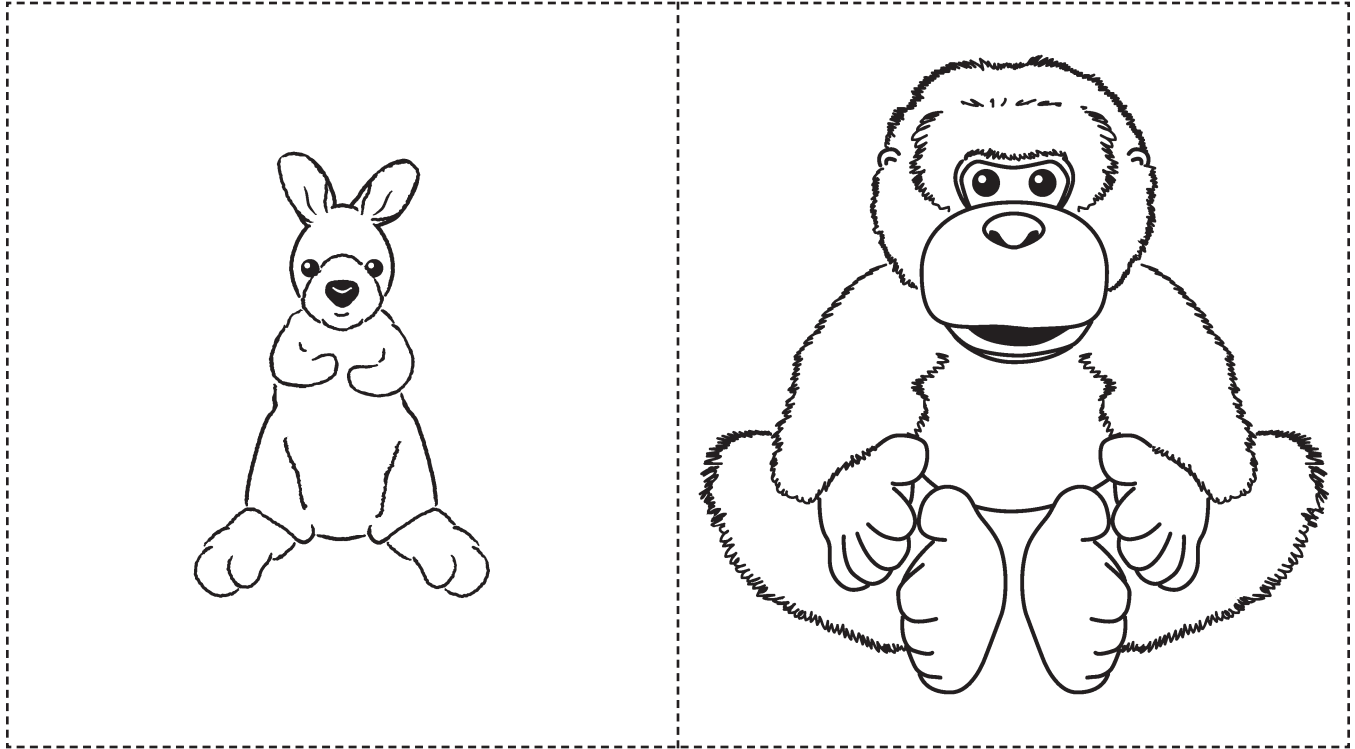

Grocery Store Spinner

Make one copy; affix overhead spinner to it.

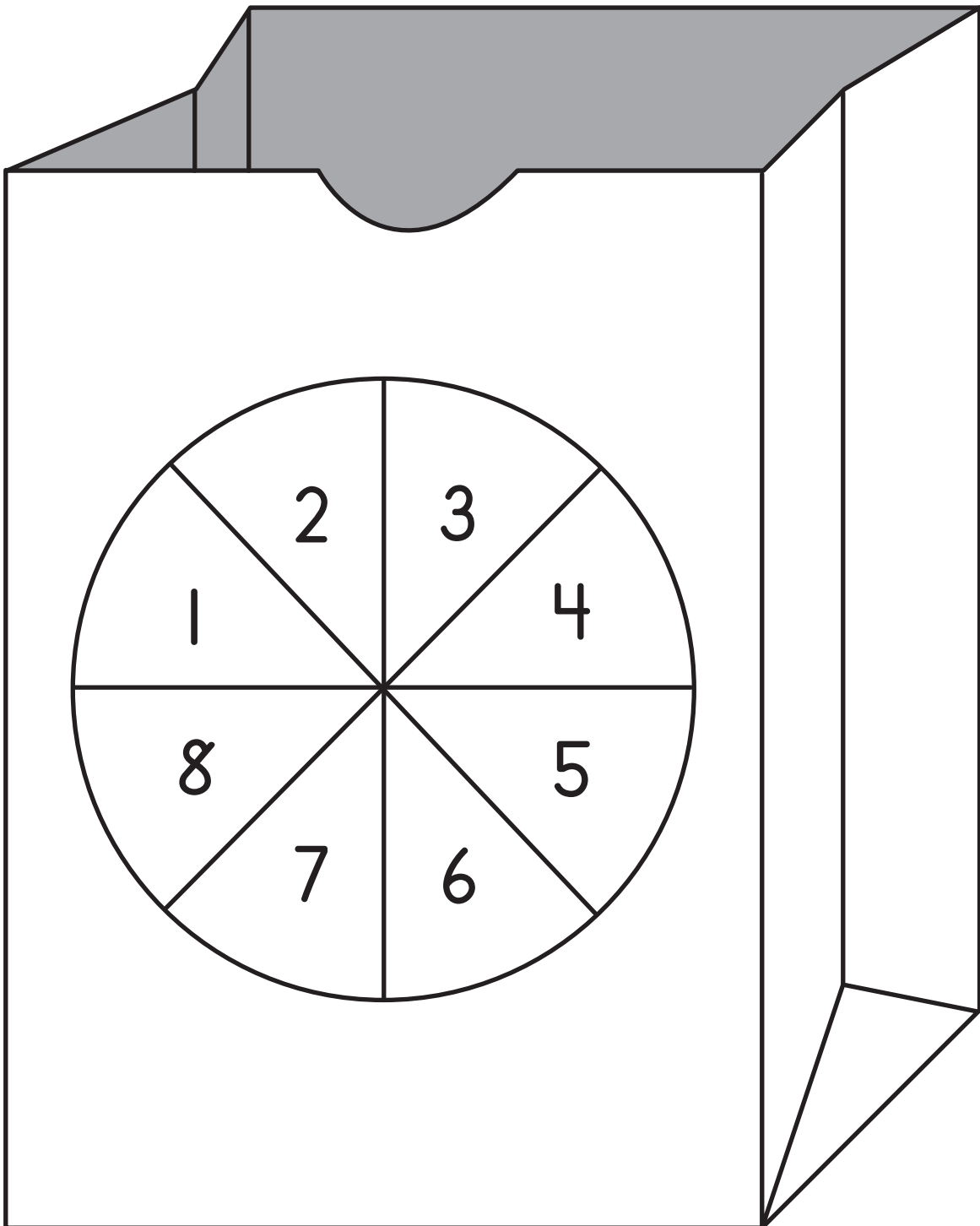

2–9 Spinner

Duplicate. Tape an overhead spinner to the center of the spinner.

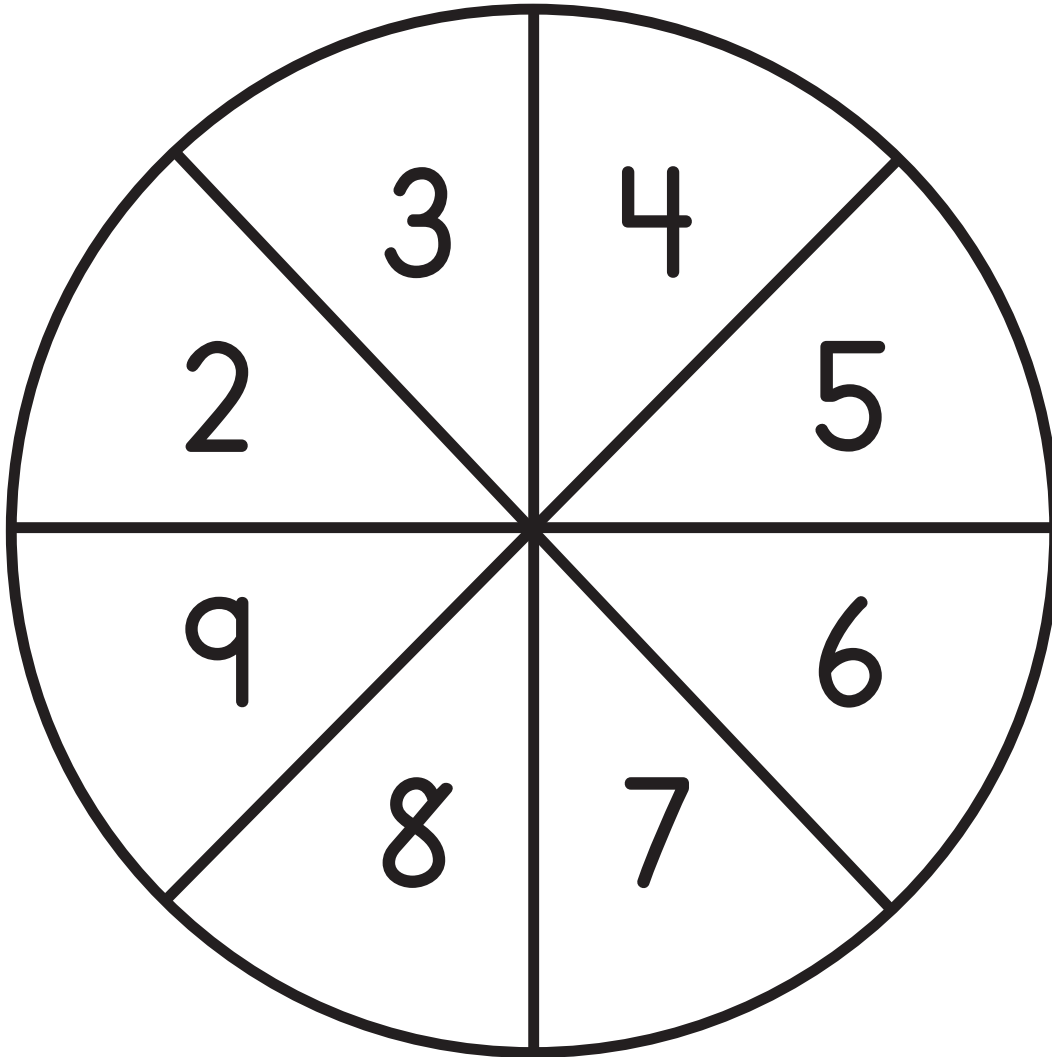

More-or-Less Spinner

Duplicate. Tape an overhead spinner to the center of the spinner.

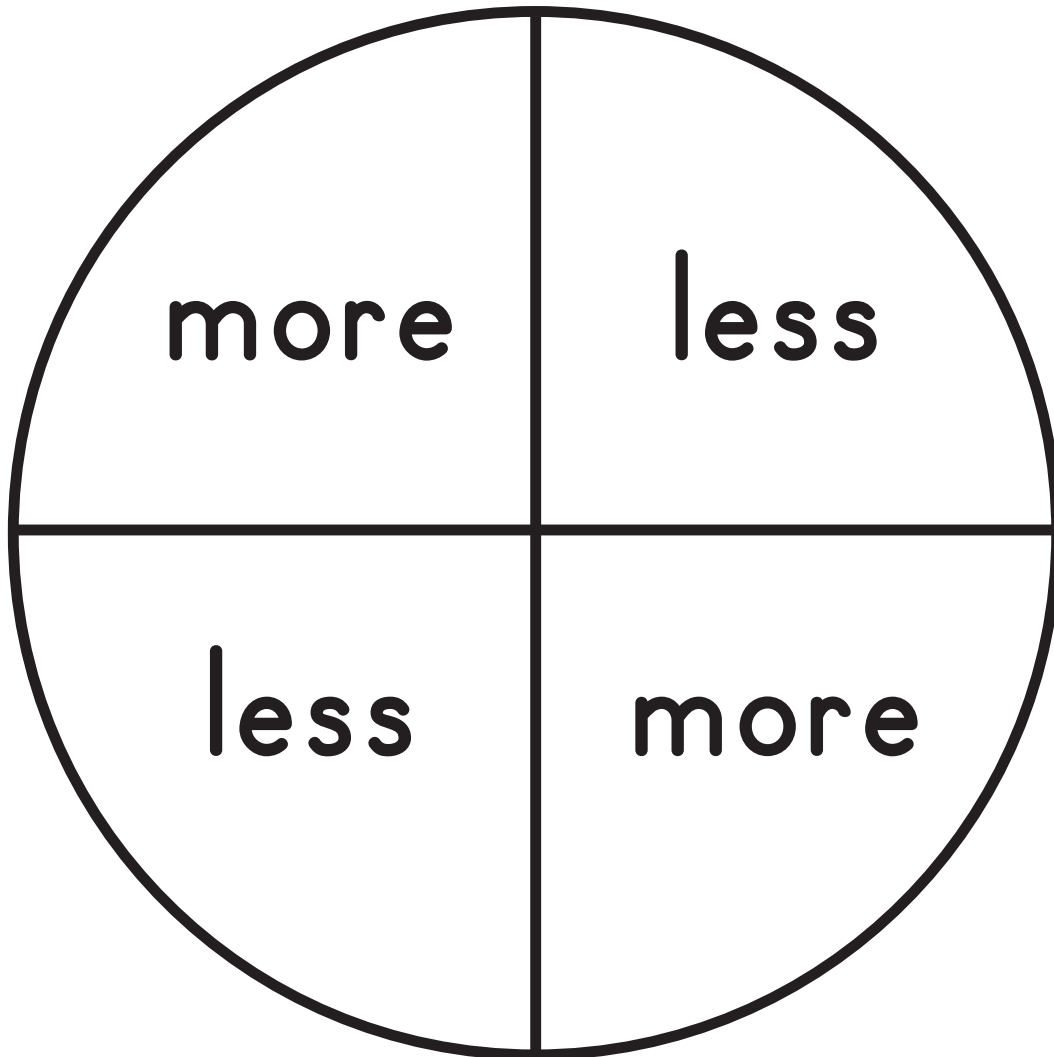

Yellow Yo-Yo "y" Pattern

Copy one per student.

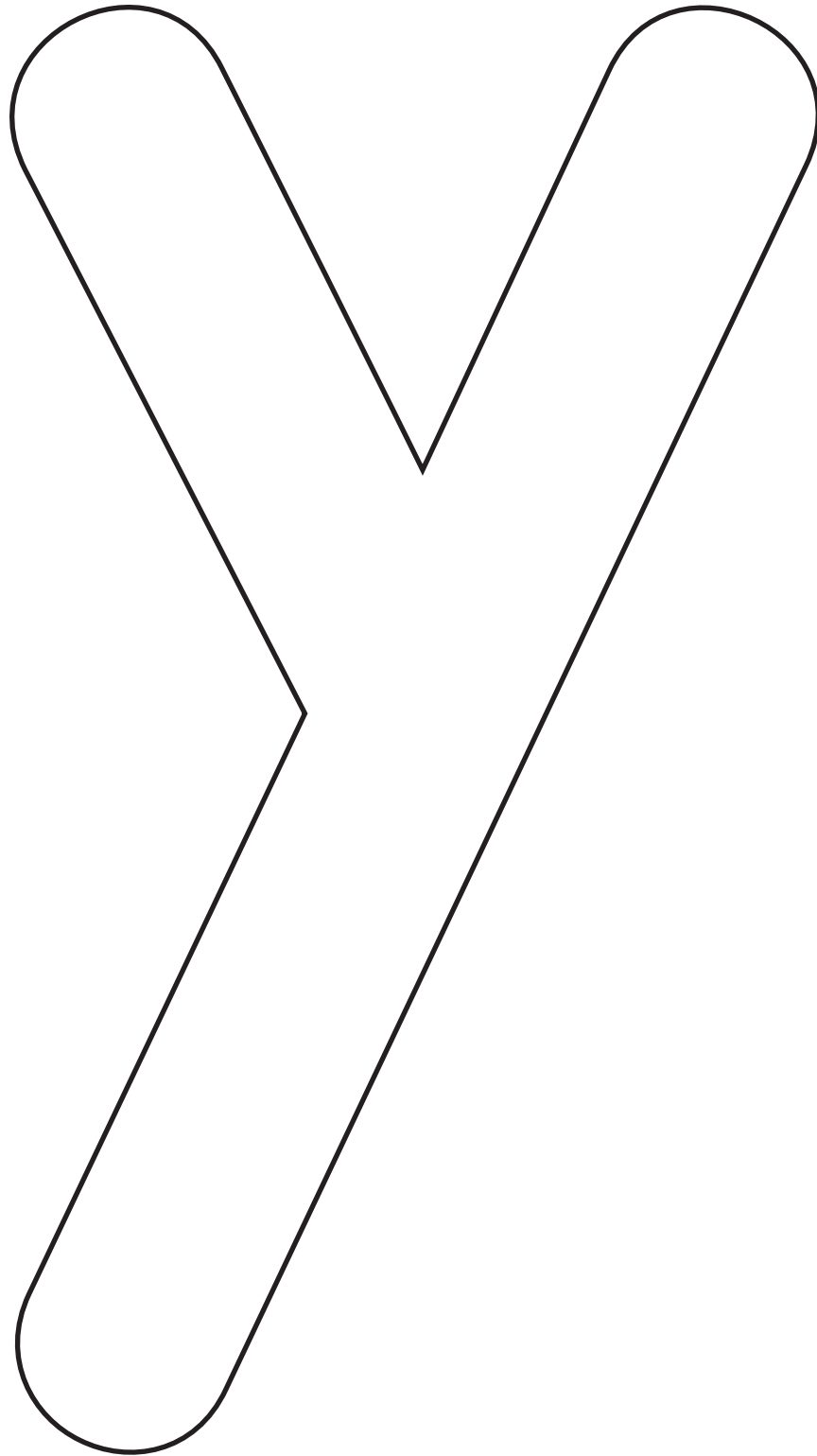

Ten-Frame Workmat

Duplicate one per student.

| | |
|--|--|
| | |
| | |
| | |
| | |
| | |

Quilting "q" Pattern

Copy one per student on cardstock, if possible.

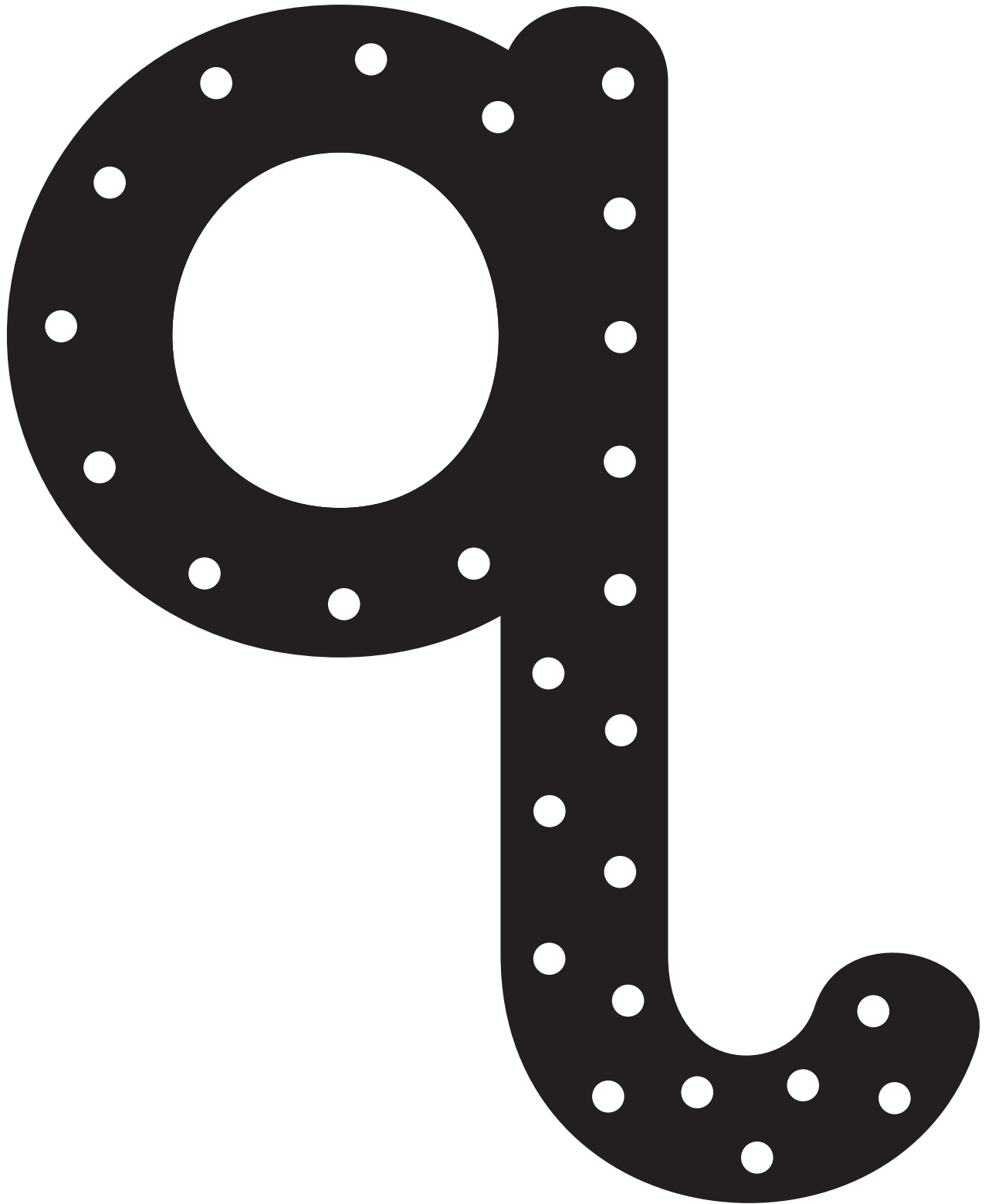

How Many Will It Hold? Workmat

Duplicate one per partnership.

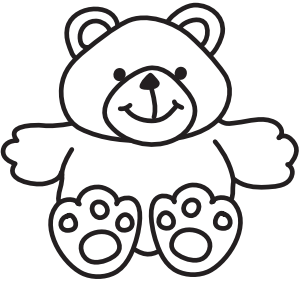
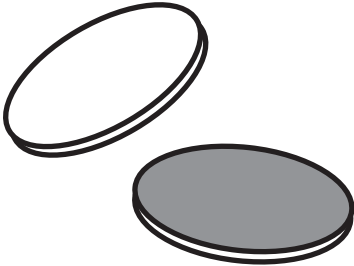
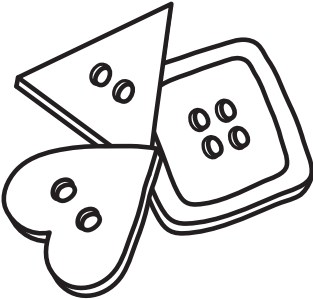
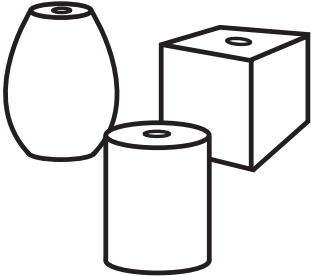
| | Guess | Actual |
|-------------------------------------------------------------------------------------|-------|--------|
|  | | |
|  | | |
|  | | |
|  | | |

Dear Family,

Good eating habits begin early in life. Eating a variety of nutritious foods helps your child to develop physically and mentally so he or she is able to focus on and be successful in daily activities.

During the first week, the children will learn the importance of good nutrition and the foods that contribute to growth and good health. Your child will see this demonstrated in a silly way in the story *Gregory, the Terrible Eater*.

The second week will focus on the market and the assortment of nutritious foods that can be found there. We will read stories that will introduce your child to the various types of markets around the world, in addition to those right in your own neighborhood. In the story *Tap-Tap*, your child will see what market day is like in Haiti. Your child may be able to identify with Max in the story *Bunny Cakes* when the young bunny struggles with writing an item on the grocery list.

How can you help?

Your child will continue to bring home simple, repetitive stories to read with you and to keep. Encourage your child to share these books with you as you help him or her with emerging reading skills.

Engage in conversation with your child, and watch the Home Link show online to reinforce the focus for the day and beginning reading and math skills.

Estimada familia:

Los hábitos alimenticios saludables empiezan a temprana edad. Comer una variedad de alimentos nutritivos ayuda a su hijo a desarrollar física y mentalmente por lo que él es capaz de concentrarse y tener éxito en las actividades diarias.

Durante la primera semana, los niños aprenderán la importancia de una buena nutrición y los alimentos que contribuyen al crecimiento y salud. Su niño verá esto de una manera tonta en la historia de *Gregory, the Terrible Eater (Gregory, el terrible devorador)*.

La segunda semana se centrará en el mercado y la variedad de alimentos nutritivos que se pueden encontrar allí. Leeremos historias que introducirán a su hijo a los diferentes tipos de mercados alrededor del mundo, y los que están en su propio vecindario. En la historia *Tap-Tap*, su hijo verá qué día de mercado es como en Haití. Su hijo puede ser capaz de identificar con Max en la historia *Bunny Cakes (Pasteles conejito)* cuando el conejito joven lucha con escribir un artículo en la lista de la compra.

¿Cómo puede ayudar?

Su hijo continuará trayendo historias simples, repetitivas para leer con usted y mantener. Anime a su hijo a compartir estos libros con ustedes como lo ayuda con habilidades de lectura emergentes.

Participar en una conversación con su hijo, y ver el programa de Home Link online para reforzar el enfoque para el día y comienzan las habilidades de lectura y matemáticas.



Weekly Record Form

Unit 6 | Week 1: What's on the Menu?

Teacher: _____ Date: _____

| Students | Graphemes | | | Oral-Language Development | | | PA | Beginning Reading | Emergent Writing | GAT | Math | | Homework |
|----------|------------------|---|---|---------------------------|-------------------------------|----------------------------------------------|---------------------------------------------------|---------------------------------------------------------------|-----------------------------------|--------------------------|-----------------------------------------------------------------------------------------------------------|--------------------------------|------------------------------------------------|
| | Reads and writes | e | l | h | SOLO vocabulary (score 0-100) | SOLO oral expression (score 70, 80, 90, 100) | Theme Vocabulary Sentence (score 70, 80, 90, 100) | Identifies initial sounds for "bike," "fork," "sheep" (D, ND) | Sounds out the word "leg" (D, ND) | | Stages Observed • Write Away • Lab Plan <input checked="" type="checkbox"/> Conference Completed | Orders objects by size (D, ND) | Measures length with nonstandard units (D, ND) |
| | R | | | | | | | | | <input type="checkbox"/> | | | |
| | W | | | | | | | | | <input type="checkbox"/> | | | |
| | R | | | | | | | | | <input type="checkbox"/> | | | |
| | W | | | | | | | | | <input type="checkbox"/> | | | |
| | R | | | | | | | | | <input type="checkbox"/> | | | |
| | W | | | | | | | | | <input type="checkbox"/> | | | |
| | R | | | | | | | | | <input type="checkbox"/> | | | |
| | W | | | | | | | | | <input type="checkbox"/> | | | |
| | R | | | | | | | | | <input type="checkbox"/> | | | |
| | W | | | | | | | | | <input type="checkbox"/> | | | |
| | R | | | | | | | | | <input type="checkbox"/> | | | |
| | W | | | | | | | | | <input type="checkbox"/> | | | |
| | R | | | | | | | | | <input type="checkbox"/> | | | |
| | W | | | | | | | | | <input type="checkbox"/> | | | |
| | R | | | | | | | | | <input type="checkbox"/> | | | |
| | W | | | | | | | | | <input type="checkbox"/> | | | |
| | R | | | | | | | | | <input type="checkbox"/> | | | |
| | W | | | | | | | | | <input type="checkbox"/> | | | |
| | R | | | | | | | | | <input type="checkbox"/> | | | |
| | W | | | | | | | | | <input type="checkbox"/> | | | |
| | R | | | | | | | | | <input type="checkbox"/> | | | |
| | W | | | | | | | | | <input type="checkbox"/> | | | |
| | R | | | | | | | | | <input type="checkbox"/> | | | |
| | W | | | | | | | | | <input type="checkbox"/> | | | |
| | R | | | | | | | | | <input type="checkbox"/> | | | |
| | W | | | | | | | | | <input type="checkbox"/> | | | |
| | R | | | | | | | | | <input type="checkbox"/> | | | |
| | W | | | | | | | | | <input type="checkbox"/> | | | |

D = Demonstrated ND = Not Demonstrated



Weekly Record Form

Unit 6 | Week 2: What's on the Menu?

Teacher: _____ Date: _____

| Students | Graphemes | | | | Oral-Language Development | | | Beginning Reading | Emergent Writing | GAT | Math | Homework | |
|----------|------------------|----|---|---|-------------------------------|----------------------------------------------|---------------------------------------------------|-------------------|------------------|--------------------------|------|----------|----|
| | Reads and writes | sh | z | w | SOLO vocabulary (score 0-100) | SOLO oral expression (score 70, 80, 90, 100) | Theme Vocabulary Sentence (score 70, 80, 90, 100) | | | | | | PA |
| | R | | | | | | | | | | | | |
| | W | | | | | | | | | <input type="checkbox"/> | | | |
| | R | | | | | | | | | <input type="checkbox"/> | | | |
| | W | | | | | | | | | <input type="checkbox"/> | | | |
| | R | | | | | | | | | <input type="checkbox"/> | | | |
| | W | | | | | | | | | <input type="checkbox"/> | | | |
| | R | | | | | | | | | <input type="checkbox"/> | | | |
| | W | | | | | | | | | <input type="checkbox"/> | | | |
| | R | | | | | | | | | <input type="checkbox"/> | | | |
| | W | | | | | | | | | <input type="checkbox"/> | | | |
| | R | | | | | | | | | <input type="checkbox"/> | | | |
| | W | | | | | | | | | <input type="checkbox"/> | | | |
| | R | | | | | | | | | <input type="checkbox"/> | | | |
| | W | | | | | | | | | <input type="checkbox"/> | | | |
| | R | | | | | | | | | <input type="checkbox"/> | | | |
| | W | | | | | | | | | <input type="checkbox"/> | | | |
| | R | | | | | | | | | <input type="checkbox"/> | | | |
| | W | | | | | | | | | <input type="checkbox"/> | | | |
| | R | | | | | | | | | <input type="checkbox"/> | | | |
| | W | | | | | | | | | <input type="checkbox"/> | | | |
| | R | | | | | | | | | <input type="checkbox"/> | | | |
| | W | | | | | | | | | <input type="checkbox"/> | | | |
| | R | | | | | | | | | <input type="checkbox"/> | | | |
| | W | | | | | | | | | <input type="checkbox"/> | | | |
| | R | | | | | | | | | <input type="checkbox"/> | | | |
| | W | | | | | | | | | <input type="checkbox"/> | | | |
| | R | | | | | | | | | <input type="checkbox"/> | | | |
| | W | | | | | | | | | <input type="checkbox"/> | | | |
| | R | | | | | | | | | <input type="checkbox"/> | | | |
| | W | | | | | | | | | <input type="checkbox"/> | | | |

D = Demonstrated ND = Not Demonstrated